



**COUNTY OF IMPERIAL
DEPARTMENT OF PUBLIC WORKS**

155 South 11th Street
El Centro, CA 92243
Phone: (442) 265-1818
Fax: (442) 265-1858

PROJECT MANUAL

**IMPERIAL COUNTY
DESERT SHORES SOCCER PARK
PHASE 1**

COUNTY PROJECT NO. SR53009



Approved by: DAVID DALE, P.E., P.L.S., ASSISTANT DIRECTOR OF PUBLIC WORKS

David Dale

Signature

10/20/23

Date

Contact person: Kimberly Cortes, Administrative Analyst I

Pre-Bid Conference Date: **November 29, 2023, at 9:00 AM**

Bid Opening Date: **December 15, 2023, at 2:00 PM**

SPECIAL NOTICE

Pursuant to the requirements of Senate Bill 854 and California Labor Code section 1725.5, all contractors and subcontractors that wish to engage in public work through a public works contract must first register with the Department of Industrial Relation and pay all applicable fees.

Beginning March 1, 2015, no contractor or subcontractor may be listed on a bid proposal for a public works project unless registered with the Department of Industrial Relations, pursuant to Labor Code section 1725.5 (with limited exceptions from this requirement for bid purposes only under Labor Code section 1771.1(a)).

Beginning April 1, 2015, no contractor or subcontractor may be awarded a contract for public work on a public works project unless registered with the Department of Industrial Relations, pursuant to Labor Code section 1725.5.

This Project is subject to compliance monitoring and enforcement by the Department of Industrial Relations.

For more information concerning Senate Bill 854 compliance, please visit: <http://www.dir.ca.gov/Public-Works/SB854.html>,

PUBLIC WORKS REFORMS (SB 854) FACT SHEET

Public works reforms (SB 854) were signed into law on June 20, 2014. The reforms made several significant changes to the administration and enforcement of prevailing wage requirements by the Department of Industrial Relations (DIR). Among other things, SB 854 established a public works contractor registration program to replace prior Compliance Monitoring Unit (CMU) and Labor Compliance Program (LCP) requirements for bond-funded and other specified public works projects. The fees collected through the program established by SB 854 are used to fund DIR's public works activities.

Essentials of public works contractor registration program:

- Contractors are subject to a registration and annual renewal fee set at \$400. This fee is non-refundable and applies to all contractors and subcontractors who intend to bid or perform work on public works projects (as defined under the Labor Code).
- Contractors apply and pay the fee online and must meet minimum qualifications to be registered as eligible to bid and work on public works projects:
 - Must have workers' compensation coverage for any employees and only use subcontractors who are registered public works contractors.
 - Must have Contractors State License Board license if applicable to trade.
 - Must not have any delinquent unpaid wage or penalty assessments owed to any employee or enforcement agency.
 - Must not be under federal or state debarment.
 - Must not be in prior violation of this registration requirement once it becomes effective. However, for the first violation in a 12-month period, a contractor may still qualify for registration by paying an additional penalty.
- The registration fee is not related to any project. It is more like a license that enables the registrant to bid on and perform public works.
- DIR provides a searchable database of registered contractors and subcontractors on its website, so that awarding bodies and contractors can comply with the requirement to only use registered contractors and subcontractors.
- Various protections are built in so that
 - A contractor won't be in violation for working on a private job that is later determined to be public work;
 - The inadvertent listing of an unregistered subcontractor on a bid doesn't necessarily invalidate that bid;
 - A contract with an unregistered contractor or subcontractor is subject to cancellation but is not void as to past work;
 - An unregistered contractor or subcontractor can be replaced with one who is registered;
 - A contractor whose registration lapses will have a 90-day grace period within which to pay a late fee and renew.
- Contractors and subcontractors register online. The preferred method of payment is by credit card.
- The requirement to list only registered contractors and subcontractors on bids became effective on March 1, 2015. The requirement to only use registered contractors and subcontractors on public works projects applies to all projects awarded on or after April 1, 2015.

Essentials of Public Works Enforcement Fund:

All contractor registration fees go into the State Public Works Enforcement Fund and are used to fund the following items:

- Administration of contractor registration requirement;
- All DIR costs for administering and enforcing public works laws;
- Labor Commissioner's enforcement of other Labor Code violations on monitored public works projects.

DIR no longer charges awarding bodies for prevailing wage compliance monitoring and enforcement on legacy CMU projects.

Related changes in DIR's administration and enforcement of public works requirements:

- Requirements to use CMU or specified alternative (labor compliance program or project labor agreement) for state bond-funded and other specified projects were eliminated and replaced by requirements that apply to *all* public works projects (as defined under the Labor Code).
- Awarding bodies are required to submit PWC-100 (contract award notice) for all public works projects.
- Contractors and subcontractors on *all* public works projects are required to submit certified payroll records (CPRs) to the Labor Commissioner unless excused from this requirement. -
 - CPRs are furnished to the Labor Commissioner online
 - This requirement phases in as follows:
 - Applied to public works projects that had been under CMU monitoring;
 - Applies to any new projects awarded on or after April 1, 2015;
 - May apply to other projects as determined by Labor Commissioner;
 - Applies to *all* public works projects, (except those listed under Exemptions just below), on and after January 1, 2016.
 - Exemptions: As of April 1, 2015, and even after January, 1, 2016, the following projects are exempt from the requirement to have contractors and subcontractors furnish certified payroll records (CPRs) to the Labor Commissioner:

Small Project Exemption

Contractors who work exclusively on small public works projects are not required to register as a public works contractor or file electronic certified payroll reports for those projects. Contractors are still required to maintain certified payroll records on a continuous basis, and provide them to the Labor Commissioner's Office upon request. Additionally, awarding agencies are not required to submit the notice of contract award through DIR's PWC-100 system on projects that fall within the small project exemption. The small project exemption applies for all public works projects that do not exceed:

- \$25,000 for new construction, alteration, installation, demolition or repair
- \$15,000 for maintenance

Any projects monitored and enforced by the following legacy LCPs:

- California Department of Transportation (Caltrans)
- City of Los Angeles
- Los Angeles Unified School District
- County of Sacramento

Projects covered by qualifying project labor agreements, at the Labor Commissioner's discretion.

- Requirements for awarding bodies to adopt and enforce a DIR-approved LCP are now limited to: (1) ongoing public works projects awarded prior to January 1, 2012, that were under a pre-existing LCP requirement (see the four legacy LCPs listed above) and (2) projects funded in whole or in part by Proposition 84.

June 2017

**IMPERIAL COUNTY
DESERT SHORES SOCCER PARK
PHASE 1**

COUNTY PROJECT NO. SR53009

TABLE OF CONTENTS

Notice to Contractor Calling for Bids _____	1
Information for Bidders _____	7
Bid Form _____	12
Non-collusion Affidavit to be Executed by Bidder and Submitted with Bid _____	16
Designation of Subcontractors _____	17
Public Contract Code Section 10162 Questionnaire _____	20
Contractor’s Certificate Regarding Workers Compensation _____	22
Bid Bond _____	23
Performance Bond _____	25
Payment Bond for Public Works _____	27
Contents of General Conditions _____	29
General Conditions _____	31
Exhibit A – General Specifications _____	67
Exhibit B – Soil Testing Reports _____	78
Exhibit C – Site Plan _____	84
Exhibit D – Sample Agreement for Services _____	94

NOTICE TO CONTRACTOR CALLING FOR BIDS

NOTICE IS HEREBY GIVEN that the COUNTY OF IMPERIAL, California, acting by and through its Board of Supervisors (hereinafter referred to as "COUNTY"), will receive up to, but not later than **2:00 PM** on **December 15, 2023** sealed bids for the award of a contract for the proposed project:

**IMPERIAL COUNTY
DESERT SHORES SOCCER PARK
PHASE 1**

COUNTY PROJECT NO. SR53009

The Contractor shall possess a California Contractor's **B or C-27** License at the time this contract is awarded.

Estimated Cost. The estimated construction cost is **\$280,000**.

Bids shall be received in the office of the Clerk of the Board of Supervisors, 940 Main Street, Suite 209, El Centro, California 92243, and shall be opened publicly and read aloud at the above stated time and place.

Each bid package must conform and be responsive to the contract documents, bid sets are available starting on **November 7, 2023**, at the following <https://publicworks.imperialcounty.org/projects-out-to-bid/> "Projects out to bid" at no charge and at Public Works, 155 South Eleventh Street, El Centro, CA, 92243, Phone (442) 265-1818, Monday through Thursday 8:00 AM - 5:00 PM (PDT) for a hard copy set for a fee. Those desiring to pick up bid sets shall call to reserve a copy of bid documents to ensure the availability.

A one hundred dollar (\$100) non-refundable fee for each hardcopy bid package set of the contract documents is required.

Only those firms who have purchased the bid documents will be mailed any addendums that may be issued for this project prior to the bid opening date.

Each bid shall be accompanied by the bid security referred to in the contract documents and the list of proposed subcontractors in the form of a certified or cashier check or a bid bond for ten percent (10%) of the maximum bid amount being proposed.

In contracts involving expenditure in excess of ten thousand dollars (\$10,000), the successful bidder shall file a payment bond in a penal sum at least equal to the full contract value as awarded. The bond shall be approved by COUNTY and shall be in the form set forth in the contract documents. The successful bidder shall also file a performance bond in a penal sum at least equal to the full contract value as awarded.

A performance and payment bond must be filed for contracts involving expenditure in excess of twenty-five thousand dollars (\$25,000), and may be required for contracts involving smaller expenditures at the option of COUNTY.

A Contractor's and Subcontractor's Pre-Bid Conference will be held on the following date: **November 29, 2023**, at **9:00 AM** at:

**IMPERIAL COUNTY
DESERT SHORES SOCCER PARK
PHASE 1**

COUNTY PROJECT NO. SR53009

Contact Person: Kimberly Cortes, Administrative Analyst I
Telephone: (442) 265-1818

Attendance at the Pre-Bid Conference and Facility Walkthrough is **RECOMMENDED.**

Before submitting a bid, ALL BIDDERS are required to examine the project site and fully inform themselves as to all existing site conditions and limitations. The bid proposal shall include the cost of all items necessary for the construction of the Project. Bidder shall not receive any additional compensation for costs resulting from conditions that Bidder could have discovered with due diligence prior to submitting a bid.

Any potential bidder whom has been deemed ineligible to perform work on public works projects pursuant to Labor Code Sections 1777.1 or 1777.7 shall be prohibited from bidding on, being awarded a contract for, or performing work as a subcontractor on this project, or any other public works project within the state of California.

COUNTY reserves the right to reject any or all bids or to waive any irregularities or informalities in any bids or in the bidding.

All information required by the bid forms must be completely and accurately provided. Numbers shall be stated in both words and figures where so indicated in the bid forms; conflicts between a number stated in words and in figures are governed by the words. Partially completed Bid Proposals, including bid forms with items left blank, or Bid Proposals submitted on other than the bid forms included herein are non-responsive and will be rejected. Bid Proposals not conforming to these instructions for bidders and the Notice to Contractors Calling for Bids may be deemed nonresponsive and rejected.

Pursuant to Section 20103.8 of the Public Contract Code: A local agency may require a bid for a public works contract to include prices for items that may be added to, or deducted from, the scope of work in the contract for which the bid is being submitted. Whenever additive or deductive items are included in a bid, the bid solicitation shall specify which one of the following methods will be used to determine the lowest bid. In the absence of a specification, only the method provided by subdivision (a) will be used:

- (a) The lowest bid shall be the lowest bid price on the base contract without consideration of the prices on the additive or deductive items.

A responsible bidder who submitted the lowest bid as determined by this section shall be

awarded the contract, if it is awarded. This section does not preclude the local agency from adding to or deducting from the contract any of the additive or deductive items after the lowest responsible bidder has been determined.

**ENGINEER’S OPINION OF PROBABLE QUANTITY
BASE BID**

AL = Allowance CF = Cubic Feet CY = Cubic Yard EA = Each LB = Pounds
 LF = Linear Foot LS = Lump Sump SF = Square Feet TON = (2,000 lbs)

ITEM No.	ITEM DESCRIPTION	UNIT	ESTIMATED QUANTITY
1.	Mobilization/Demobilization, temporary facilities, construction sign, insurance, bonds, taxes, fees, permits and similar expenses	LS	1
2.	Dust Control	LS	1
3.	Soil Preparation and Fine Grading	LS	1
4.	Furnish and Install Landscaping per Plan	LS	1
5.	Furnish and Install Irrigation System per Plan	LS	1
6.	90-Day Landscape Maintenance	LS	1

Nothing in this section shall preclude the prequalification of subcontractors.

COUNTY hereby affirms and notifies all bidders that it will affirmatively ensure that in any contract entered into pursuant to this advertisement, disadvantaged business enterprises will be afforded full opportunity to submit bids in response to this invitation and will not be discriminated on the grounds of race, sex, color, or national origin in consideration for an award.

Pursuant to section 1773 of the Labor Code, the general prevailing rate of wages in the County in which the work is to be done has been determined by the Director of the California Department of Industrial Relations and are on file and available from the Clerk of the Board of Supervisors located at the County Administration Center, 940 Main Street, El Centro, CA 92243.

The Director of Industrial Relations has determined the general prevailing rate of per diem wages in the locality in which this work is to be performed for each craft or type of worker needed to execute the contract which will be awarded to the successful bidder.

Use the following internet access URL:
[Director's General Prevailing Wage Determinations \(ca.gov\)](http://www.dir.ca.gov)

It shall be mandatory upon the Contractor to whom the contract is awarded, and upon any subcontractor under it, to pay not less than the said specified rates to all workers employed by them in the execution of the contract. No bidder may withdraw their bid for a period of ninety (90) days after the date set for the opening of bids.

Bidders are advised that they may elect to substitute securities for any retention of funds by the County to ensure performance under the Contract. At the request and expense of Bidder, securities equivalent to the amount retained shall be deposited with the

County, or with a state or federally chartered bank in this state as the escrow agent, who shall then return the securities to Bidder once the Project has been completed.

Alternatively, the Bidder may request, and the County shall make payment of retentions earned directly to the escrow agent at the expense of the Bidder. The Bidder, at its sole cost and expense, may direct the investment of the payments into securities, and the Bidder shall receive the interest earned on the investments. Once the Project has been completed, the Bidder shall receive from the escrow agent all securities, interest and payments received by the escrow agent from the County.

Securities eligible for investment include those listed in Cal Gov Code § 16430, bank or savings and loan certificates of deposit, interest-bearing demand deposit accounts, standby letters of credit, or any other security mutually agreed to by the County and the Bidder. The Bidder shall be the beneficial owner of any securities substituted for retained funds and shall receive any interest thereon.

Substitution of securities shall be conducted through an Escrow Agreement substantially similar to that found in Cal Pub Contract Code § 22300(f).

PLEASE NOTE: Substitution of securities is prohibited where funding for the Project, in whole or in part, will be provided by the Farmers Home Administration of the United States Department of Agriculture pursuant to the Consolidated Farm and Rural Development Act (7 U.S.C. Sec 1921 et seq.) or where otherwise disallowed by federal law.



Blanca Acosta
Clerk of the Board of Supervisors



Date

Approved for Construction



John A. Gay, P. E.
Director of Public Works



Date

VICINITY MAP



IMPERIAL COUNTY
PUBLIC WORKS
DEPARTMENT
EL CENTRO, CA

Imperial County
Desert Shores Soccer Park
PHASE 1

County Project No. SR53009

LOCATION MAP



IMPERIAL COUNTY
PUBLIC WORKS
DEPARTMENT
EL CENTRO, CA

Imperial County
Desert Shores Soccer Park
PHASE 1
County PROJECT NO. SR53009

INFORMATION FOR BIDDERS

1. Preparation of Bid Form. COUNTY invites bids on the form attached to be submitted at such time and place as is stated in the form *Notice to Contractors Calling for Bids*. All blanks in the bid form must be appropriately completed, and all prices must be stated in both words and figures. All bids must be submitted in sealed envelopes bearing on the outside the name of the bidder, the bidder's address, and the name of the project for which the bid is submitted. It is the sole responsibility of the bidder to see that the bid is received by COUNTY prior to the date and time specified for opening bids. Any bid received after the scheduled closing time for receipt of bids will be returned to the bidder unopened.
2. Bid Security. Each bid shall be accompanied by a certified or cashier's check payable to COUNTY or a satisfactory bid bond in favor of COUNTY executed by the bidder as principal and a satisfactory surety company as surety, in an amount not less than ten percent (10%) of the maximum amount of the bid. The check or bid bond shall be given as guarantee that the bidder shall execute the contract if it be awarded to it in conformity with the contract documents and shall provide the surety bond or bonds as specified therein within ten (10) days after notification of the award of the contract to the bidder.
3. Signature. The bid must be signed in the name of the bidder and must bear the signature in longhand of the person or persons duly authorized to sign the bid.
4. Modifications. Changes in or additions to the bid form, recapitulations of the work bid upon, alternative proposals, or any other modification of the bid form which is not specifically called for in the contract documents may result in COUNTY's rejection of the bid as not being responsive to the invitation to bid. No oral or telephonic modification may be considered.

Any proposed modifications of a bidder's bid must be in writing and received by COUNTY prior to the date and time specified for opening bids.
5. Erasures. The bid submitted must not contain any erasures, interlineations, or other corrections unless each such correction is suitably authenticated by affixing in the margin immediately opposite the correction and the surname, or surnames of the person or persons signing the bid.
6. Examination of Site and Contract Documents. Each bidder shall visit the site of the proposed work and fully acquaint itself with the conditions relating to the construction and labor so that it may fully understand the facilities, difficulties and restrictions attending the execution of the work under the contract. Bidders shall thoroughly examine and be familiar with the drawings and specifications. The failure or omission of any bidder to receive or examine any contract documents, form, instrument, addendum or other document, or to visit the site and acquaint itself with conditions there existing, shall in no way relieve any bidder from obligations with respect to its bid or to the contract. The submission of a bid shall be taken as *prima facie* evidence of compliance with this section.

7. Withdrawal of Bids. Any bidder may withdraw its bid either personally, by written request, or by telegraphic request confirmed in the manner specified above at any time prior to the scheduled closing time for receipt of bids.
8. Relief from Mistake in Bid. The attention of bidders is called to Public Contracts Code sections 5100 to 5104, particularly the requirements of section 5103 which requires that grounds for relief from a mistaken bid require written notice to the public entity within five (5) working days after the opening of the bids of mistake and such notice shall detail how the mistake occurred. Please note that a bidder shall not be relieved of its bid unless the elements of Public Contract Code section 5103 are met and the written consent of COUNTY is obtained and/or by order of a court of competent jurisdiction.
9. Agreements and Bonds. The agreement form which the successful bidder, as Contractor, will be required to execute, and the forms and amounts of the surety bonds which it will be required to furnish at the time of execution of the agreements, are included in the contract documents and should be carefully examined by the bidder. The required number of executed copies of the *Agreement*, the *Performance Bond*, and the *Payment Bond* for County Projects is as specified in the *Special Conditions*.
10. Interpretation of Plans and Documents. If any person contemplating submitting a bid for the proposed contract is in doubt as to the true meaning of any part of the drawings, specifications or other contract documents, or finds discrepancies in or omissions from the drawings and specifications, he or she shall submit to COUNTY a written request for an interpretation or correction thereof no less than ten (10) days prior to the bid opening. The person submitting the request will be responsible for its prompt delivery. Any interpretations or correction of the contract documents will be made only by addendum duly issued, and a copy of such addendum will be mailed or delivered to each person receiving a set of the contract documents. No oral interpretation of any provision in the contract documents will be made to any bidder. The interpretation of Plans and documents upon bid award shall be addressed in accordance with Article 2 of the "General Conditions."
11. Bidders Interested in More Than One Bid. No person, firm, or corporation shall be allowed to make, or file, or be interested in more than one bid for the same work unless alternate bids are specifically called for. A person, firm, or corporation that has submitted a sub-proposal to a bidder, or that has quoted prices of materials to a bidder, is not thereby disqualified from submitting a sub-proposal or quoting prices to other bidders or make a prime proposal.
12. Award of Contract. COUNTY reserves the right to reject any or all bids, or to waive any irregularities or informalities in any bids or in the bidding. The award of the contract, if made by COUNTY, will be to the lowest responsible bidder therefore. Award of the contract may be on January 2023 (tentative), and an Agreement shall be presented to the successful bidder at that time. Successful bidder shall then have ten (10) days to execute the Agreement and provide all payment and performance bonds required for this project. Please note that a posted tabulation may be a preliminary tabulation which has not been reviewed for responsiveness

and responsibility. It is possible that the lowest bidder will not be awarded the contract because of non-responsiveness or non-responsibility.

13. Alternates. If alternate bids are called for, the contract may be awarded at the election of the governing board to the lowest responsible bidder on the base bid, or on the base bid and any alternate or combination of alternates.
14. Bidder Contact Information. The bidder shall submit complete name, address and phone listings, (including fax), and contact person at bidder's company, provide a complete list of all personnel, subcontractors, and other agencies that will be assigned to this project and the responsibility that each will have.
15. Listing Subcontractors. Each bidder shall submit with its sealed bid a list of the proposed subcontractors on this project as required by the Subletting and Subcontracting Fair Practices Act (Pub. Cont. Code, § 4100, et seq.). Forms for this purpose are furnished with the contract documents.
16. Workers Compensation and Prevailing Wage Compliance.
 - 16.1. Workers Compensation. In accordance with the provisions of Labor Code section 3700 *et. seq.* Contractor shall secure the payment of compensation to its employees. Contractor shall sign and file with COUNTY the following certificates prior to performing the work under this contract: "I am aware of the provisions of section 3700 of Labor Code which require every employer to be insured against liability for workers compensation or to undertake self-insurance in accordance with the provisions of that code, and I will comply with such provisions before commencing the performance of the work of this contract." The form of such certificate is included as a part of the contract documents.
 - 16.2. Prevailing Wage Compliance. Contractor and its subcontractors shall pay all workers employed on the Project the rates determined by the Director of the California Department of Industrial Relations (DIR). Copies of the State prevailing rate of per diem wages are on file with the Department of Industrial Relations, Division of Apprenticeship Standards, 445 Golden Gate Avenue, San Francisco, California, and at COUNTY's Department of Public Works, and are available to Contractor and any other interested party upon request. Contractor shall post the prevailing rate of per diem wages to be posted at the Project site.
 - 16.3. For those Projects subject to Department of Industrial Relations (DIR) Monitoring and Enforcement, be advised that the Contractor is responsible for submitting certified payroll records directly to the State Compliance Monitoring Unit (CMU). CMU is a new component within the State Division of Labor Standards Enforcement (DLSE) that was created to monitor and enforce prevailing wage requirements on public works projects that receive state bond funding and on other projects that are legally required to use the CMU. The CMU began operations on January 1, 2012, following the recent adoption of AB 436 and approval of revisions to program regulations. By actively monitoring compliance on an ongoing basis while work is being

performed, the CMU will play a special role in ensuring that public works construction workers are promptly paid the proper prevailing wage rates and in helping maintain a level playing field for contractors who comply with the law.

Effective Date and Applicability: The laws and regulations that govern the new program are effective January 1, 2012. Only projects for which the public works contract is awarded on or after January 1, 2012 are subject to the CMU requirements. For further information concerning compliance monitoring please visit the website located at: <https://www.dir.ca.gov/Public-Works/publicworks.html>.

- 17. Substitution of Security. Contractors may substitute securities in place of retained funds withheld by COUNTY in accordance with the provisions of Cal. Pub. Contract Code Section 22300.
- 18. Contractor's Pre-Bid Conference.
 - 18.1. A Pre-Bid Conference will be held on the following date: **November 29, 2023, at 9:00 AM** at:

**IMPERIAL COUNTY
DESERT SHORES SOCCER PARK
PHASE 1**

COUNTY PROJECT NO. SR53009

Contact Person: Kimberly Cortes, Administrative Analyst
E-mail: kimberlycortes@co.imperial.ca.us

- 18.2. Attendance at the Pre-Bid Conference and Walkthrough is **RECOMMENDED.**
 - 18.3. Before submitting a bid, ALL BIDDERS are required to examine the project site and fully inform themselves as to all existing site conditions and limitations. The bid proposal shall include the cost of all items necessary for the construction of the Project. Bidder shall not receive any additional compensation for costs resulting from conditions that Bidder could have discovered with due diligence prior to submitting a bid.
 - 18.4. In accordance with Paragraph 10 of the Information for Bidders, any questions to be presented at the Pre-Bid Conference must be in writing and received by COUNTY from General Contractor or subcontractor submitting a Bid on or before **December 6, 2023, at 4:00 PM** in the Public Works office located at 155 South Eleventh Street, El Centro, California, 92243.
19. Calendar of Events.

1. Bid packages available	<u>November 6, 2023</u>
---------------------------	--------------------------------

2.	Pre-Bid Conference and Facility Walkthrough	<u>November 29, 2023 at 9:00am</u>
3.	Return of Written Plans, Document Questions, and Substitution Requests. <u>Please be advised that Substitution Requests submitted after the due date may render this bid unresponsive.</u>	<u>December 6, 2023 at 4:00pm</u>
4.	Bid package, inclusive of completed bid forms, and bid bond required to be submitted hereunder must be received by COUNTY on or before at: Clerk of the Board 940 Main Street, Suite 209 El Centro, CA 92243 Phone: (760) 482- 4220	<u>December 15, 2023 at 2:00pm</u>
5.	Bid Opening in Board Chambers	<u>December 15, 2023 at 2:00pm</u>
6.	Board of Supervisors review and consideration of award on approximately	<u>January 2024 (Tentative)</u>
7.	Execution of Contract	<u>February 2024 (Tentative)</u>
8.	Commencement of construction on or before	<u>March 2024 (Tentative)</u>
9.	Completion of construction on	<u>May _____ 2024 (Tentative)</u>

BID FORM

TO: Acting by and through its Board of Supervisors, hereinafter called COUNTY.

1. Pursuant to and in compliance with your *Notice to Contractors Calling for Bids* and the other documents relating thereto, the undersigned bidder, having familiarized itself with the terms of the contract, the local conditions affecting the performance of the contract, and the cost of the work at the place where the work is to be done, and with the drawings and specifications and other contract documents, hereby proposes and agrees to perform, within the time stipulated by the contract, including all of its component parts and everything required to be performed, and to provide and furnish any and all of the labor, materials, tools, expendable equipment and all utility and transportation services necessary to perform the contract and complete it in a workmanlike manner, all of the work required in connection with the

**IMPERIAL COUNTY
DESERT SHORES SOCCER PARK
PHASE 1**

COUNTY PROJECT NO. SR53009

All in strict conformity with the drawings and specifications and other contract documents, including addenda nos., _____, _____, _____, and _____, on file at the office of Public Works Facilities Management, for the total sum of _____ Dollars (\$ _____), hereinafter called the *Base Bid Price*.

Warning - If an addendum or addenda have been issued by the Department and not noted above as being received by the bidder, this proposal may be rejected.

COUNTY reserves the right to make award or any combination of base bid process plus deductive bid items as COUNTY determines to be in its best interest.

AL = Allowance CF = Cubic Feet CY = Cubic Yard EA = Each LB = Pounds
 LF = Linear Foot LS = Lump Sump SF = Square Feet TON = (2,000 lbs)

ITEM No.	ITEM DESCRIPTION	UNIT	EST. QUANTITY	UNIT PRICE	TOTAL
1.	Mobilization/Demobilization, temporary facilities, construction sign, insurance, bonds, taxes, fees, permits and similar expenses	LS	1		
2.	Dust Control	LS	1		
3.	Soil Preparation and Fine Grading	LS	1		
4.	Furnish and Install Landscaping per Plan	LS	1		
5.	Furnish and Install Irrigation System per Plan	LS	1		
6.	90-Day Landscape Maintenance	LS	1		

TOTAL BASE BID: _____

Note: The amount entered as the "Total Base Bid" should be identical to the Base Bid amount entered in Section 1 of the Bid Proposal form.

Warning - If an addendum or addenda have been issued by the Department and not noted above as being received by the bidder, this proposal may be rejected.

COUNTY reserves the right to make award or any combination of base bid process plus deductive bid items as COUNTY determines to be in its best interest.

2. It is understood that COUNTY reserves the right to reject this bid and that this bid shall remain open and not be withdrawn for the period specified in the Notice to Contractors Calling for Bids.

3. The required bid security is hereto attached.

4. The required list of proposed subcontractors is attached hereto.

5. It is understood and agreed that if written notice of the acceptance of this bid is mailed, telegraphed, or delivered to the undersigned after the opening of the bid, and within the time this bid is required to remain open, or at any time thereafter before this bid is withdrawn, the undersigned will execute and deliver to COUNTY a contract in the form attached hereto in accordance with the bid as accepted, and that it will also furnish and deliver to COUNTY the Performance Bond and Payment Bond for the Public Works as specified, all within ten (10) days after receipt of notification of award, and that the work under the contract shall be commenced by the undersigned bidder, if awarded the Contractor, on the date to be stated in COUNTY's Notice to Contractors to Proceed, and shall be completed by the Contractor in the time specified in the contract documents.

6. Notice of acceptance or requests for additional information should be addressed to the undersigned at the address identified in Paragraph 8 below.

7. Print/type the names of all persons interested in the foregoing proposal as principals in the space provided below:

(IMPORTANT NOTICE: If bidder or other interested person is a corporation, state legal name of corporation, also names of the president, secretary, treasurer, and manager thereof; if a co-partnership, state true name of firm, also names of all individual co-partners composing firm; if bidder or other interested person is an individual, state first and last names in full.)

8. Licensed in accordance with act providing for the registration of Contractors:

Company Name: _____
 Company Address: _____
 Contact Name: _____
 Contact Email #: _____
 Phone #: _____
 License #: _____ Expiration Date: _____
 Classification (s): _____
 DIR Registration #: _____ Expiration Date: _____
 Gross Annual Receipts for the Firm: _____
 Years in Business: _____
 Age of Firm: _____

9. The undersigned certifies that he/she is now licensed in the appropriate trade in accordance with the provisions of the Contractor's License Law of the State of California, and the number of said license is _____ and that said license expires _____, 20____.

10. By my signature on this proposal I certify, under penalty or perjury under the laws of the State of California, that the foregoing questionnaire and statements of Public Contract Code sections 10162, 10232 and 10285.1 are true and correct and that the bidder has complied with the requirements of section 8103 of the Fair Employment and Housing Commission Regulations (Chapter 5, Title 2 of the California Administrative Code). By my signature on this proposal I further certify, under penalty or perjury under the laws of the State of California and the United States of America, that the Non-collusion Affidavit required by Title 23 United States Code, section 112 and Public Contract Code section 7106; and the Title 49 Code of Federal Regulations, Part 29 Debarment and Suspension Certification are true and correct.

Date: _____ By: _____

 (Signature of bidder)

 (Print/type signator's name)

 (Print/type title)

NOTE: If bidder is a corporation, the legal name of the corporation shall be set forth above, together with the signatures of authorized officers or agents, and the document shall bear the corporate seal; if bidder is a partnership, the true name of the firm shall be set forth above, together with the signature of the partner or partners authorized to sign contracts

on behalf of the partnership; and if bidder is an individual, his/her signature shall be placed above.

Business Address: _____

Place of Residence: _____

Telephone: _____

Fax Number: _____

**NON-COLLUSION AFFIDAVIT TO BE EXECUTED
BY BIDDER AND SUBMITTED WITH BID**

State of California

County of Imperial

_____ [name of individual], being first duly sworn,
deposes and says that he or she is _____ [title of individual] of
_____ [name of business] the party making the
foregoing bid that the bid is not made in the interest of, or on behalf of, any undisclosed
person, partnership, company, association, organization, or corporation; that the bid is
genuine and not collusive or sham; that the bidder has not directly or indirectly induced or
solicited any other bidder to put in a false or sham bid, and has not directly or indirectly
colluded, conspired, connived, or agreed with any bidder or anyone else to put in a sham
bid, or that anyone shall refrain from bidding; that the bidder has not in any manner, directly
or indirectly, sought by agreement, communication, or conference with anyone to fix the bid
price of the bidder or any other bidder, or to fix any overhead, profit, or cost element of the
bid price, or of that of any other bidder, or to secure any advantage against the public body
awarding the contract of anyone interested in the proposed contract; that all statements
contained in the bid are true; and, further, that the bidder has not, directly or indirectly,
submitted his or her bid price or any breakdown thereof, or the contents thereof, or divulged
information or data relative thereto, or paid, and will not pay, any fee to any corporation,
partnership, company association, bid depository, or to any member or agent thereof to
effectuate a collusive or sham bid.

Signature

DESIGNATION OF SUBCONTRACTORS

In compliance with the Subletting and Subcontracting Fair Practices Act (Ch. 4 (commencing at section 4100), Div. 2, part 1 of the Cal. Pub. Cont. Code) and any amendments thereof, each bidder shall set forth below:

(a) (1) The name, the location of the place of business, the California contractor license number, and public works contractor registration number issued pursuant to Section 1725.5 of the Labor Code of each subcontractor who will perform work or labor or render service to the prime contractor in or about the construction of the work or improvement, or a subcontractor licensed by the State of California who, under subcontract to the prime contractor, specially fabricates and installs a portion of the work or improvement according to detailed drawings contained in the plans and specifications, in an amount in excess of one-half of 1 percent of the prime contractor's total bid or, in the case of bids or offers for the construction of streets or highways, including bridges, in excess of one-half of 1 percent of the prime contractor's total bid or ten thousand dollars (\$10,000), whichever is greater.

(b) the portion of the work which will be done by each subcontractor under this act. The prime Contractor shall list only one subcontractor for each such portion as is defined by the prime Contractor in this bid.

If a prime contractor fails to specify a subcontractor or if a prime contractor specifies more than one subcontractor for the same portion of work to be performed under the contract in excess of one-half of 1 percent of the prime contractor's total bid, the prime contractor agrees that he or she is fully qualified to perform that portion himself or herself, and that the prime contractor shall perform that portion itself.

No prime Contractor whose bid is accepted shall (a) substitute any subcontractor, (b) permit any subcontractor to be voluntarily assigned or transferred or allow it to be performed by anyone other than the original subcontractor listed in the original bid, or (c) sublet or subcontract any portion of the work in excess of one-half of one percent (1/2%) of 1 percent of the prime Contractor's total bid as to which his original bid did not designate a subcontractor, except as authorized in *Subletting and Subcontracting Fair Practices Act*.

Subletting or subcontracting of any portion of the work in excess of one-half of one percent (1/2%) of 1 percent of the prime Contractor's total bid as to which no subcontractor was designated in the original bid shall only be permitted in cases of public emergency or necessity, and then only after a finding reduced to writing as a public record of the authority awarding this contract setting forth the facts constituting the emergency or necessity.

If all work is to be done without subcontractors, write "None" in the following space:

SUBCONTRACTOR LIST

For each Subcontractor that will perform a portion of the Work in an amount in excess of one-half of 1% of the Bidder's total contract Price, the bidder must list a description of the Work, the name of the Subcontractor, its California contractor license number, the location of its place of business, its DIR registration number, and the portion of the Work that the Subcontractor is performing based on a percentage of the Base Bid price.

TYPE OF WORK SUBCONTRACTOR WILL DO	NAME UNDER WHICH SUBCONTRACTOR IS LICENSED	CALIFORNIA CONTRACTOR LICENSE NO.	ADDRESS	DIR REG. NO.	PERCENT OF WORK

SUPPLIERS

NAME OF SUPPLIER	ADDRESS & TELEPHONE No.	TYPE OF MATERIAL

(Proper Name of Bidder)

By:

(Signature of bidder)

(Print/type signator's name)

(Print/type title)

PUBLIC CONTRACT CODE SECTION 10162 QUESTIONNAIRE

In accordance with Public Contract Code section 10162, the Bidder shall complete, under penalty of perjury, the following questionnaire:

Has the bidder, any officer of the bidder, or any employee of the bidder who has a proprietary interest in the bidder, ever been disqualified, removed or otherwise prevented from bidding on, or completing a federal, state or local government project because of a violation of law or a safety regulation?

Yes _____ No _____

If the answer is yes, explain the circumstances in the following space.

PUBLIC CONTRACT SECTION 10232 STATEMENT

In accordance with Public Contract Code section 10232, the Contractor hereby states, under penalty of perjury, that no more than one final unappealable finding of contempt of court by a federal court has been issued against the Contractor within the immediately preceding two year period because of the Contractor's failure to comply with an order of a federal court which orders the Contractor to comply with an order of the National Labor Relations Board.

TITLE 23, UNITED STATES CODE, SECTION 112 NON-COLLUSION AFFIDAVIT

In accordance with Title 23, United States Code, section 112, the bidder hereby states under penalty of perjury, that he has not, either directly or indirectly, entered into any agreement, participated in any collusion, or otherwise taken any action in restraint of free competitive bidding in connection with this contract.

Note: The above Statement questionnaire, and Non-Collusion Affidavit are part of the Proposal. Signing this Proposal on the signature portion thereof shall also constitute Signature of this Statement, Questionnaire, and Non-Collusion Affidavit.

Bidders are cautioned that making a false certification may subject the certifier to criminal prosecution.

PUBLIC CONTRACT CODE SECTION 10285.1 STATEMENT

In accordance with Public Contract Code section 10285.1 (Chapter 376, Stat. 1985), the bidder hereby declares under penalty of perjury under the laws of the State of California that the bidder has _____, has not _____ been convicted within the preceding three (3) years of any offenses referred to in that section, including any charge of fraud, bribery, collusion, conspiracy, or any other act in violation of any state or federal antitrust law in connection with the bidding upon, award of, or performance of, any public works contract, as defined in Public Contract Code section 1101, with any public entity, as defined in Public Contract Code section 1100, including the Regents of the University of California or the Trustees of

the California State University. The term "bidder" is understood to include any partner, member, officer, director, responsible managing officer, or responsible managing employee thereof, as referred to in section 10285.1

NOTE: THE BIDDER MUST PLACE A CHECK MARK AFTER "HAS" or "HAS NOT" IN ONE OF THE BLANK SPACES PROVIDED.

THE ABOVE STATEMENT IS PART OF THE PROPOSAL. SIGNING THIS PROPOSAL ON THE SIGNATURE PORTION THEREOF SHALL ALSO CONSTITUTE SIGNATURE OF THIS STATEMENT.

BIDDERS ARE CAUTIONED THAT MAKING A FALSE CERTIFICATION MAY SUBJECT THE CERTIFIER TO CRIMINAL PROSECUTION.

**CONTRACTOR'S CERTIFICATE
REGARDING WORKERS COMPENSATION**

Labor Code section 3700 in relevant part provides:

"Every employer except the State shall secure the payment of compensation in one or more of the following ways:

- (a) By being insured against liability to pay compensation in one or more insurers duly authorized to write compensation insurance in this State.

- (b) By securing from the Director of Industrial Relations a *Certificate of Consent to Self-Insure*, either as an individual employer, or as one employer in a group of employers, which may be given upon furnishing proof satisfactory to the Director of Industrial Relations of ability to be self-insured and to pay any compensation that may become due to his or her employees."

I am aware of the provisions of section 3700 of the Labor Code which require every employer to be insured against liability for workers compensation or to undertake self-insurance in accordance with the provisions of that Code, and I will comply with such provisions before commencing the performance of the work of this contract.

(Proper Name of Bidder)

By: _____
(Signature of bidder)

(Print/type signator's name)

(Print/type title)

(In accordance with Article 5 (commencing at section 1860), Chapter 1, Part 7, Division 2 of the Labor Code, the above certificate must be signed and filed with the awarding body prior to performing any work under this contract.)

BID BOND

KNOW ALL MEN BY THESE PRESENTS, that we _____ as Principal, and _____ as Surety, are held and firmly bound unto the _____ County, hereinafter called COUNTY, in the penal sum of TEN PERCENT (10%) OF THE TOTAL AMOUNT OF THE BID of the Principal submitted to COUNTY for the work described below for the payment of which sum in lawful money of the United States, well and truly to be made, we bind ourselves, our heirs, executors, administrators, successors and assigns, jointly and severally, firmly by these presents.

THE CONDITION OF THIS OBLIGATION IS SUCH that whereas the Principal has submitted the accompanying bid dated _____, 20 _____, for

IMPERIAL COUNTY
DESERT SHORES SOCCER PARK
PHASE 1

COUNTY PROJECT NO. SR53009

NOW, THEREFORE, if the Principal shall not withdraw said bid within the period specified therein after the opening of the same, or, if no period be specified, within ninety (90) days after said opening, and if the Principal is awarded the contract, and shall within the period specified therefore, or, if no period be specified, within five (5) days after the prescribed forms are presented to it for signature, enter into the written contract with COUNTY in accordance with the bid as accepted and give bond with good and sufficient surety or sureties, as may be required, for the faithful performance and proper fulfillment of such contract and for the payment for labor and materials used for the performance of the contract, or in the event of the withdrawal of said bid within the period specified or the failure to enter into such contract and give such bonds within the time specified, if the Principal shall pay COUNTY the difference between the amount specified in said bid and the amount for which COUNTY may procure the required work and/or supplies, if the latter amount be in excess of the former; together with all costs incurred by COUNTY in again calling for bids, then the above obligation shall be void and of no effect, otherwise to remain in full force and virtue.

Surety, for value received, hereby stipulates and agrees that no change, extension of time, alterations or addition to the terms of the contract on the call for bids, or to the work to be performed thereunder, or the specifications accompanying the same, shall in anywise affect its obligation under this bond, and it does hereby waive notice of any such change, extension of time, alteration or addition to the terms of said contract or the call for bids, or to the work, or to the specifications.

In the event suit is brought upon this bond by COUNTY and judgment is recovered, Surety shall pay all costs incurred by COUNTY in such suit, including reasonable attorneys' fees to be fixed by the Court.

IN WITNESS WHEREOF, the above-bound parties have executed this instrument under their several seals this _____ day of _____, 20 _____, the name and corporate seal of each corporate party being hereto affixed, and these presents

duly signed by its undersigned representative, pursuant to authority of its governing body.

(Corporate Seal)

(Proper Name of Principal)

By: _____
(Signature)

(Print/type signator's name)

(Print/type title)

(Corporate Seal)

(Proper Name of Surety)

By: _____
(Signature)

(Print/type signator's name)

(Print/type title)

(Attached Attorney-In-Fact Certificate)

PERFORMANCE BOND

Whereas, The Board of Supervisors of the County of Imperial, State of California, and _____, (hereinafter designated as "principal") have entered into an agreement whereby principal agrees to install and complete certain designated public improvements, which said agreement, dated _____, 20__, and identified as project IMPERIAL COUNTY DESERT SHORES SOCCER PARK, PHASE 1 ; COUNTY PROJECT NO. SR53009, is hereby referred to and made a part hereof; and

Whereas, Said principal is required under the terms of said agreement to furnish a bond for the faithful performance of said agreement.

Now, therefore, we, the principal and _____ (hereinafter designated as "surety"), are held and firmly bound unto the County of Imperial (hereinafter designated as "County") in the penal sum of _____ dollars (\$_____) lawful money of the United States, for the payment of which sum well and truly to be made, we bind ourselves, our heirs, successors, executors and administrators, jointly and severally, firmly by these presents.

The condition of this obligation is such that if the above-bounded principal, his or its heirs, executors, administrators, successors or assigns, shall in all things stand to and abide by, and well and truly keep and perform the covenants, conditions and provisions in the said agreement and any alteration thereof made as therein provided, on his or their part, to be kept and performed at the time and in the manner therein specified, and in all respects according to their true intent and meaning, and shall indemnify and save harmless County, its officers, agents and employees, as therein stipulated, then this obligation shall become null and void; otherwise it shall be and remain in full force and effect.

As a part of the obligation secured hereby and in addition to the face amount specified therefore, there shall be included costs and reasonable expenses and fees, including reasonable attorneys' fees, incurred by County in successfully enforcing such obligation, all to be taxed as costs and included in any judgment rendered.

The surety hereby stipulates and agrees that no change, extension of time, alteration or addition to the terms of the agreement or to the work to be performed thereunder or the specifications accompanying the same shall in anywise affect its obligations on this bond, and it does hereby waive notice of any such change, extension of time, alteration or addition to the terms of the agreement or to the work or to the specifications.

In witness whereof, this instrument has been duly executed by the principal and surety above named, on _____, 20_____.

Principal

By:

Surety

By:

Attorney-In-Fact

[Attach Required Acknowledgment]

PAYMENT BOND

Whereas, The Board of Supervisors of the County of Imperial, State of California, and _____ hereinafter designated as "the principal") have entered into an agreement whereby the principal agrees to install and complete certain designated public improvements, which agreement, dated _____, 20____, and identified as project IMPERIAL COUNTY DESERT SHORES SOCCER PARK, PHASE 1 ; COUNTY PROJECT NO. SR53009, is hereby referred to and made a part hereof; and

Whereas, Under the terms of the agreement, the principal is required before entering upon the performance of the work, to file a good and sufficient payment bond with the County of Imperial to secure the claims to which reference is made in Title 3 (commencing with section 9000) of Part 6 of Division 4 of the Civil Code.

Now, therefore, the principal and the undersigned as corporate surety, are held firmly bound unto the County of Imperial and all contractors, subcontractors, laborers, material suppliers, and other persons employed in the performance of the agreement and referred to in Title 3 (commencing with section 9000) of Part 6 of Division 4 of the Civil Code in the sum of _____ dollars (\$_____), for materials furnished or labor thereon of any kind, or for amounts due under the Unemployment Insurance Act with respect to this work or labor, that the surety will pay the same in an amount not exceeding the amount hereinabove set forth, and also in case suit is brought upon this bond, will pay, in addition to the face amount thereof, costs and reasonable expenses and fees, including reasonable attorneys' fees, incurred by the County of Imperial in successfully enforcing this obligation, to be awarded and fixed by the court, and to be taxed as costs and to be included in the judgment therein rendered.

It is hereby expressly stipulated and agreed that this bond shall inure to the benefit of any and all persons, companies, and corporations entitled to file claims under Title 3 (commencing with section 9000) of Part 6 of Division 4 of the Civil Code, so as to give a right of action to them or their assigns in any suit brought upon this bond.

Should the condition of this bond be fully performed, then this obligation shall become null and void, otherwise it shall be and remain in full force and effect.

The surety hereby stipulates and agrees that no change, extension of time, alteration, or addition to the terms of the agreement or the specifications accompanying the same shall in any manner affect its obligations on this bond, and it does hereby waive notice of any such change, extension, alteration, or addition.

In witness whereof, this instrument has been duly executed by the principal and surety above named, on _____, 20_____.

Principal

By:

Surety

By:

[Attach Required Acknowledgment]

Attorney-In-Fact

CONTENTS OF GENERAL CONDITIONS

Article 1.	Definitions	31
Article 2.	Drawings and Specifications	31
Article 3.	Copies Furnished	31
Article 4.	Ownership of Drawings	32
Article 5.	Detail Drawings and Instructions	32
Article 6.	Time for Completion and Damages for Delay	32
Article 7.	Progress Schedule	32
Article 8.	Contract Security	32
Article 9.	Assignment	33
Article 10.	Prohibited Interests	33
Article 11.	Separate Contracts	33
Article 12.	Subcontracting	34
Article 13.	Defaults & Remedies	34
Article 14.	Warranties	36
Article 15.	Notices and Reports	37
Article 16.	Workers	37
Article 17.	Prevailing Wages & Payroll Records	38
Article 18.	Apprentices	39
Article 19.	Hours of Work	40
Article 20.	Insurance Coverages	40
Article 21.	Special Insurance Requirements	41
Article 22.	Insurance Endorsements, Clauses & Information	41
Article 23.	Proof of Insurance	42
Article 24.	Choice of Law	42
Article 25.	Permits and Licenses	42
Article 26.	Easements	42
Article 27.	Surveys	43
Article 28.	Excise Taxes	43
Article 29.	Patents and Royalties	43
Article 30.	Materials	43
Article 31.	Substitutions	44
Article 32.	Shop Drawings	44
Article 33.	Samples	45
Article 34.	Cost Breakdown and Periodical Estimates	45
Article 35.	Payments	45
Article 36.	Payment Withheld	46
Article 37.	Changes and Extra Work	47
Article 38.	Deductions for Uncorrected Work	48

Article 39.	Payments by Contractor	48
Article 40.	Contractor's Supervision	48
Article 41.	Inspector's Field Office	49
Article 42.	Documents on Work	49
Article 43.	Utilities and Relocation	49
Article 44.	Sanitary Facilities	50
Article 45.	Trenches	50
Article 46.	Protection of Work and Property	51
Article 47.	Lay Out and Field Engineering	52
Article 48.	Cutting and Patching	52
Article 49.	Cleaning Up	52
Article 50.	Correction of Work	52
Article 51.	Access to Work	53
Article 52.	Occupancy	53
Article 53.	County's Inspector	53
Article 54.	Tests and Inspections	53
Article 55.	Soils Investigation Report	54
Article 56.	Architect/Engineer's and Construction Manager's Status	54
Article 57.	Indemnities	55
Article 58.	Provisions Required by Law Deemed Inserted	55
Article 59.	Labor - Employment Safety	56
Article 60.	Notice of Taxable Possessory Interest	56
Article 61.	Assignment of Unfair Business Practices Claims (Clayton Act & Cartwright Act)	56
Article 62.	Substitution of Security	56
Article 63.	Non-Discrimination & Disadvantaged Business Enterprise Program	57
Article 64.	Special Conditions *	57
Article 65.	Contract Construction	58
Article 66.	Cognizance of Violations by County	58
Article 67.	Labor Standards Compliance Requirements	58
Article 68.	Conflict of Interest and Gratuities	59
Article 69.	Federal Contract Requirements	59
Article 70.	Ineligibility	64
Article 71.	Resolution of Claims	64
Article 72.	Miscellaneous	65

GENERAL CONDITIONS

Article 1. DEFINITIONS

- (a) COUNTY and Contractor are those mentioned as such in the Agreement. They are treated throughout the Agreement as if they are of singular number and neuter gender.
- (b) Subcontractor, as used herein, includes those having direct contract with Contractor and one who furnishes material work to a special design according to plans and specifications of this work, but does not include one who merely furnishes material not so worked.
- (c) Surety is the person, firm, or corporation that executes as surety the *Contractor's Performance Bond* and *Payment Bond for the Public Works*.
- (d) Provide shall include "provide complete in place," that is, "furnish and install."
- (e) As Shown, As Indicated, As Detailed, refer to drawings accompanying these specifications.
- (f) Work of the Contractor or subcontractor includes labor or materials, or both.

Article 2. DRAWINGS AND SPECIFICATIONS

Contract Documents are complementary, and what is called for by one shall be as binding as if called for by all. The intention of documents is to include all labor and materials, equipment, and transportation necessary for the proper execution of work. Materials or work described in words which so apply have a well-known technical or trade meaning, and shall be deemed to refer to such recognized standards.

Interpretations. Figured dimensions on drawings shall govern, but work not dimensioned shall be as directed. Work not particularly shown or specified shall be the same as similar parts that are shown or specified. Large-scale details shall take precedence over smaller scaled drawings as to shape and details of construction. Specifications shall govern as to materials, workmanship, and installation procedures. Drawings and specifications are intended to be fully cooperative and to agree. However, if Contractor observes that drawings and specifications are in conflict, it shall promptly notify the Architect in writing, and any necessary changes shall be adjusted as provided in the contract for changes in work.

Misunderstanding of drawings and specifications shall be clarified by the Architect, whose decision shall be final.

Standards, Rules, and Regulations referred to are recognized printed standards, and shall be considered as one and a part of these specifications within limits specified.

Article 3. COPIES FURNISHED

Contractor will be furnished, free of charge, copies of drawings and specifications as set forth in *Special Conditions*. Additional copies may be obtained at cost of reproduction.

Article 4. OWNERSHIP OF DRAWINGS

All drawings, specifications, and copies thereof furnished by COUNTY are its property. They are not to be used on other work, and, with exception of signed contract sets, are to be returned to COUNTY on request at completion of work.

Article 5. DETAIL DRAWINGS AND INSTRUCTIONS

- (a) In case of ambiguity, conflict, or lack of information, Architect/Engineer shall furnish with reasonable promptness additional instructions, by means of drawings or otherwise, necessary for proper execution of work. All such drawings and instructions shall be consistent with contract documents, true developments thereof, and reasonably inferable therefrom.
- (b) Work shall be executed in conformity therewith, and Contractor shall do no work without proper drawings and instructions.

Article 6. TIME FOR COMPLETION AND DAMAGES FOR DELAY

The Parties recognize that time is of the essence of the Agreement and that COUNTY will suffer financial loss if the Work is not completed by the date set forth in paragraph 19.9 of the Information to Bidders section of this Agreement. The Parties also recognize the delays, expense and difficulties involved with proving in a legal proceeding the actual loss suffered by COUNTY if the Work is not completed on time. Accordingly, instead of requiring any such proof, the Parties agree that as damages for delay (but not as a penalty), Contractor shall pay COUNTY the sum of **three thousand and six hundred dollars 00/100 dollars (\$3,600)** for each calendar day the Work remains uncompleted after the time specified in this article or any written extension, whichever is later. Contractor agrees that the damages are not manifestly unreasonable under the circumstances and agree that such sum is not intended as a penalty against Contractor.

Article 7. PROGRESS SCHEDULE

Immediately after being awarded contract, Contractor shall prepare an estimated progress schedule (using the Critical Path Method (CPM) through a software program selected by COUNTY but at Contractor's sole expense) and submit the schedule for COUNTY's approval. Schedule shall indicate graphically the beginning and completion dates of all phases of construction. An updated progress schedule shall be submitted to COUNTY on a monthly basis.

Article 8. CONTRACT SECURITY

Unless otherwise specified, Contractor shall furnish a surety bond in an amount equal to one hundred percent (100%) of the contract price as security for faithful performance of this contract, and shall furnish a separate bond in an amount equal to one hundred percent (100%) of the contract price as security for payment of persons performing labor and furnishing materials in connection with this contract. Aforesaid bonds shall be in form set forth in these contract documents. Upon request of Contractor, COUNTY will consider and accept multiple sureties on such bonds. COUNTY may reject at its discretion any bond issued by a surety that to COUNTY's satisfaction does not have a sufficient bond rating or history as a surety in the State of California to assure adequate security to COUNTY for the default of Contractor.

Article 9. ASSIGNMENT

Contractor shall not assign this contract or any part thereof without prior written consent of COUNTY. Any assignment of money due to or to become due under this contract shall be subject to a prior lien for services rendered or material supplied for performance of work called for under said contract in favor of all persons, firms, or corporations rendering such services or supplying such materials to the extent that claims are filed pursuant to the Civil Code, the Code of Civil Procedure, Public Contract Code and/or the Government Code.

Article 10. PROHIBITED INTERESTS

No official of COUNTY who is authorized in such capacity and on behalf of COUNTY to negotiate, make, accept or approve, or to take part in negotiating, making, accepting or approving, any architectural, engineering, inspection, construction, or material supply contract or any subcontract in connection with construction or project shall become directly or indirectly interested financially in this contract or in any part thereof. No officer, employee, architect, attorney, engineer, or inspector of or for COUNTY who is authorized in such capacity and on behalf of COUNTY to exercise any executive, supervisory, or other similar functions in connection with construction of project shall become directly or indirectly interested financially in this contract or in any part thereof.

Article 11. SEPARATE CONTRACTS

COUNTY reserves the right to let other contracts in connection with this work. Contractor shall afford other Contractors reasonable opportunity for introduction and storage of their materials and execution of their work and shall properly connect and coordinates its work with theirs.

If any part of Contractor's work depends for proper execution or results upon work of any other Contractor, the Contractor shall inspect and promptly report to Architect/Engineer any defects in such work that render it unsuitable for such proper execution and results. Contractor's failure so to inspect and report shall constitute its acceptance of other Contractor's work as fit and proper for reception of Contractor's work, except as to defects which may develop in other Contractor's work after execution of Contractor's work.

To ensure proper execution of its subsequent work, Contractor shall measure and inspect work already in place, and shall at once report to Architect any discrepancy between executed work and contract documents.

Contractor shall ascertain to its own satisfaction the scope of the project and nature of any other contracts that have been or may be awarded by COUNTY in prosecution of the project to the end that Contractor may perform its contract in the light of such other contracts, if any. Nothing herein contained shall be interpreted as granting to Contractor exclusive occupancy at site of project. Contractor shall not cause any unnecessary hindrance or delay to any other Contractor working on project. If simultaneous execution of any contract for the project is likely to cause interference with performance of some other contract or contracts, COUNTY shall decide which Contractor shall cease work temporarily and which Contractor shall continue or whether work can be coordinated so that Contractors may proceed simultaneously. COUNTY shall not be responsible for any damages suffered or extra costs incurred by Contractor resulting directly or indirectly from award or performance or attempted performance of any other contract or contracts on project, or caused by any decision or omission of COUNTY respecting the order of

precedence in performance of contracts.

Article 12. SUBCONTRACTING

- (a) Contractor agrees to bind every subcontractor by terms of the contract as far as such terms are applicable to subcontractor's work. If Contractor shall subcontract any part of this contract, Contractor shall be as fully responsible to COUNTY for acts and omissions of Contractor's subcontractor and of persons either directly or indirectly employed by Contractor's subcontractor as it is for acts and omissions of persons directly employed by itself. Nothing contained in the contract documents shall create any contractual relation between any subcontractor and COUNTY.
- (b) COUNTY's consent to or approval of any subcontractor under this contract shall not in any way relieve Contractor of its obligations under this contract, and no such consent or approval shall be deemed to waive any provision of this contract.
- (c) Substitution or addition of subcontractors shall be permitted only as authorized by California Public Contract Code sections 4100, et seq.
- (d) Contractor represents and warrants that it and its subcontractors are not ineligible to work for COUNTY due to violations of Labor Code sections 1777.1 and 1777.7.

Article 13. DEFAULTS & REMEDIES

- (a) Default. In the event that (i) Contractor files a petition requesting relief under any bankruptcy act, or is adjudged as bankrupt, or makes a general assignment for the benefit of creditors or has a receiver appointed on account of its insolvency, or (ii) Contractor refuses or is unable, for whatever reason, to supply enough properly skilled workers or proper materials to complete the Project, or (iii) Contractor fails to follow the directions of COUNTY, or (iv) Contractor fails to make prompt payment to its subcontractors and suppliers for materials or labor supplied or permits any lien to be imposed upon all or any portion of the Project, or (v) Contractor disregards any laws or orders of any public or private authority having jurisdiction over the Work or the Project, or (vi) Contractor fails to perform in accordance with any of the terms of this Agreement or breaches any provision of this Agreement, COUNTY may give notice of such failure or breach to Contractor, identifying the failure or breach of this Agreement. Should any such failure or breach continue for twenty-four (24) hours after delivery of notice without a good faith effort on the part of Contractor to commence all necessary corrective action, or should such a breach continue despite Contractor's efforts for forty-eight (48) hours, then at that time such failure shall be deemed a default by Contractor under this Agreement and COUNTY shall have all rights and remedies available at law or in equity, including the right to terminate this Agreement. Without limiting its rights and remedies, COUNTY may then proceed as follows:
 - (1) Without terminating this Agreement or the obligations of Contractor hereunder as to all of the Work required to be performed or furnished by Contractor pursuant to this Agreement, COUNTY may require Contractor, at Contractor's expense, to cure such default(s) as may exist in the performance of Contractor's obligations hereunder within forty-eight (48) hours after such default(s) has/have occurred

including but not limited to repairing, replacing, and correcting material or Work determined by COUNTY to be defective or not complying with the requirements of this Agreement. Should Contractor fail to timely repair, replace, and/or correct non-complying or defective materials and workmanship or otherwise cure its default(s) hereunder, and in the case of emergencies in which case COUNTY may act immediately if Contractor is not available or is not responding, and without further notice, COUNTY may make required repairs, replacements and other corrections or otherwise remedy the default by Contractor pursuant to Paragraph (2) below.

- (2) Without terminating this Agreement or the obligations of Contractor hereunder as to all of the Work required to be performed or furnished by Contractor pursuant to this Agreement, COUNTY may engage another contractor to perform such portion of Contractor's Work required pursuant to this Agreement or furnish any materials or other items required hereunder as COUNTY in its sole discretion may deem necessary to avoid delay in the progress of the Work, and in connection therewith, COUNTY may perform such Work or any portion thereof itself or have the same performed by others and COUNTY may procure all necessary materials, equipment or other items required for the continued progress of such Work. The costs incurred by COUNTY as a result of engaging another Contractor shall be deducted from the compensation payable pursuant to this Agreement and if COUNTY's costs exceed or may reasonably be anticipated to exceed the balance of the compensation due to Contractor for such work, such excess, or anticipated excess, shall be immediately due and owing from Contractor to COUNTY and may be withheld from any funds due to Contractor pursuant to this Agreement or any other agreement.
 - (3) COUNTY may terminate Contractor's right to perform upon written notice and COUNTY shall then have the option of completing the Work or any portion thereof by exercise of its interest under the performance bond issued in favor by Contractor, or having such Work in whole or in part be completed by others for Contractor's account. A calculation shall take place at the conclusion of the Project wherein to the degree the sum of COUNTY's costs and any amounts paid to complete the Project exceed the compensation payable pursuant to this Agreement, then any such excess shall be immediately due and owing from Contractor to COUNTY.
- (b) Damages. Contractor shall be liable for all damages suffered by COUNTY by reason of Contractor's default in any provision of this Agreement and the exercise of COUNTY of its option to terminate this Agreement shall not release Contractor of such liability. Contractor shall have no right to receive any further payment after a default has occurred until such time as the Work to be performed by Contractor pursuant hereto has been completed and accepted by COUNTY and damages suffered by COUNTY, if any, ascertained. Damages shall include by way of illustration, but not of exclusion, COUNTY's costs of completing the Work which exceeds the compensation payable pursuant to this Agreement, other general, liquidated, special or consequential damages, attorney fees, and costs.
- (c) Actions After Default. Should COUNTY exercise any of its options, remedies, or rights

granted pursuant to the terms of this Agreement in the event of a default by Contractor, COUNTY at its sole election may, but shall not be obligated to, use any materials, supplies, tools or equipment on the work site which belong to CONTRACTOR to complete the Work required to be completed by Contractor, whether such work is completed by COUNTY or by others, and Contractor agrees that it shall not remove such materials, supplies, tools and equipment from the work site unless directed in writing by COUNTY to do so.

- (d) Limit on Force Majeure Damages. Contractor shall not be responsible for repairing or restoring damage to work caused by an act of God, provided that the work damaged is built in accordance with accepted and applicable building standards and the plans and specifications of COUNTY. In the event of such damage, COUNTY may, at its option, elect to terminate this Agreement. For purposes of this Agreement, an “act of God” shall be defined as an earthquake in excess of 3.5 on the Richter scale and a tidal wave.
- (e) No Limitation of Rights. The options and rights granted to COUNTY herein shall not be deemed as limitations upon the other rights and remedies of COUNTY in the event of a failure of performance or breach by Contractor, and COUNTY shall be entitled to exercise the rights and remedies hereinabove specified and all other rights and remedies which may be provided in this Agreement or by law or in equity, either cumulatively or consecutively, and in such order as COUNTY in its sole discretion shall determine.

Article 14. WARRANTIES

- (a) One-Year Warranty. Contractor agrees to provide a one-year warranty for all of its work and component parts and guarantees that all work shall be performed in a professional and workman-like manner and be free from defects. Contractor guarantees to timely correct all work performed by it under this Agreement which COUNTY determines to be defective in design, material, and/or workmanship within a period of one (1) year from the date of the completion of the Work. The warranties set forth in this Agreement shall be in addition to, and not in lieu of, all other statutory and case law warranties and obligations of Contractor. Contractor expressly agrees that all warranties made by Contractor, all obligations under this Agreement and all remedies for breach of such warranties shall survive this Agreement in the event it is terminated or expires for any reason prior to the running of the full warranty periods listed above.

Note: Product Warranty on specifications.

- (b) Materials. All materials furnished by Contractor shall be new, manufactured during the current year, of first quality, and carrying full manufacturer’s warranty. Contractor shall be responsible for any expiration of manufacturer or other warranties of material or equipment being supplied for this Agreement. Contractor guarantees that all warranties of material and equipment shall become effective when the project is accepted by COUNTY’s Board of Supervisors, not at time of installation by Contractor.
- (c) Manufacturers’ Warranty Information. Contractor agrees to promptly provide such information and maintenance recommendations to COUNTY at the inception of

Contractor's work to the extent such information is reasonably available. In the event of failure of Contractor to comply with above-mentioned conditions within one (1) week after being notified in writing, COUNTY is hereby authorized to proceed to have defects repaired and made good at expense of Contractor, who hereby agrees to pay costs and charges therefore immediately on demand.

Article 15. NOTICES AND REPORTS

(a) All notices and reports under this Agreement shall be in writing and may be given by personal delivery or by mailing by certified mail, addressed as follows:

COUNTY

Imperial County Department of Public Works
Attention: Director
155 South Eleventh Street
El Centro, CA 92243

With Copies to:

Imperial County Executive Office
Attention: County Executive Officer
940 West Main Street, Suite 208
El Centro, CA 92243

and:

Imperial County Department of Human
Resources and Risk Management
Attention: Director
940 West Main Street, Suite 101
El Centro, CA 92243

CONTRACTOR

Business Name:

Address:

(b) Notices and reports under this Agreement may be given by personal delivery or by mailing by certified mail at such other address as either Party may designate in a notice to the other Party given in such manner. Any notice given by mail shall be considered given when deposited in the United States Mail, postage prepaid, addressed as provided herein.

Article 16. WORKERS

(a) Contractor shall at all times enforce strict discipline and good order among its employees, and shall not employ on work any unfit person or anyone not skilled in work assigned to that person. Contractor shall at all times enforce rules and standards regarding sensitive information. Contractor shall not permit workers to touch or otherwise touch, read, review, copy, or access any sensitive or confidential information. Contractor shall be responsible for any worker violating sensitive information standards.

(b) Any person in the employ of the Contractor whom COUNTY may deem incompetent or unfit shall be dismissed from work, and shall not again be employed on it except

with written consent of COUNTY.

- (c) Contractor shall provide COUNTY with a list of all current employees. Contractor shall notify COUNTY of all new employees one week prior to their start date.
- (d) All Contractor's employees shall be required to comply with the work rules established for the project site; and shall be identified while on the premises by picture identification card furnished at his/her expense, indicating their name or number; and by shirt, blouse or smock indicating the company name or logo in print large enough to be easily read. Contractor's employees shall have effective communication skills to perform such tasks and communicate with the COUNTY and its representatives.
- (e) It shall be the responsibility of Contractor to ensure all workers do not access sensitive information. COUNTY shall have the right to perform a background check and clearance requirements of all workers that have access to sensitive information. Notwithstanding anything in this agreement to the contrary, the Contractor must comply with background check and clearance requirements of the California Department of Justice (DOJ) and the California Department of Motor Vehicles (DMV) relating to any Contractor employee who has physical access to any area which is either connected to, or contains records from, the DOJ criminal computer database, including without limitation, the California Law Enforcement Telecommunications System and the Criminal Offender Record Information, or the DMV computer database (collectively, "the Databases"). If requested by the COUNTY, the Contractor must provide to the COUNTY suitable documentation evidencing the Contractor's compliance with the policies, practices, and procedures of the DOJ and the DMV regarding background check and clearance requirements relating to access to the Databases.

Article 17. PREVAILING WAGE AND PAYROLL RECORDS

- (a) Contractor agrees to comply with sections 1775 and 1776 of the California Labor Code relating to the payment of prevailing wage and the maintenance of certified payroll records and to make the certified payroll records available for inspection at all reasonable hours at Contractor's principal office. For those Public Works Projects that are subject to the State Department of Industrial Relations (DIR), Division of Labor Standards Enforcement (DLSE) compliance monitoring and enforcement it is the Contractor's responsibility to submit certified payroll records directly to the state Compliance Monitoring Unit (CMU). More information concerning state compliance can be found at <https://www.dir.ca.gov/Public-Works/publicworks.html>. The responsibility for compliance with these provisions is fixed with Contractor. Contractor understands and agrees that it shall, as a penalty to COUNTY, forfeit specific monetary fines for each worker paid less than the prevailing wage rates as determined by the Labor Commissioner for the work or craft in which the worker is employed for any Work done pursuant to this Agreement.
- (b) Notwithstanding paragraph (a), Contractor is not liable for any penalties pursuant to paragraph (a) when a subcontractor on the Project fails to pay its workers the general prevailing rate of per diem wages unless:
 - (1) Contractor had knowledge of that failure of the subcontractor to pay the specified

prevailing rate of wages to those workers; or

- (2) Contractor fails to comply with all of the following requirements:
 - (A) The contract executed between Contractor and the subcontractor for the performance of Work on the Project shall include a copy of the provisions of California Labor Code sections 1771, 1775, 1776, 1777.5, 1813 and 1815; and
 - (B) Contractor shall monitor the payment of the specified general prevailing rate of per diem wages by the subcontractor to the employees, by periodic review of the certified payroll records of the subcontractor; and
 - (C) Upon becoming aware of the failure of the subcontractor to pay his or her workers the specified prevailing rate of wages, Contractor shall diligently take corrective action to halt or rectify the failure, including, but not limited to, retaining sufficient funds due the subcontractor for work performed on the public works project; and
 - (D) Prior to making final payment to the subcontractor for Work performed on the Project, Contractor shall obtain an affidavit signed under penalty of perjury from the subcontractor that the subcontractor has paid the specified general prevailing rate of per diem wages to his or her employees on the Project and any amounts due pursuant to California Labor Code section 1813.
 - (E) Prevailing Wage Compliance. Contractor and its subcontractors shall pay all workers employed on the Project the rates determined by the Director of the California Department of Industrial Relations (DIR). Copies of the State prevailing rate of per diem wages are on file with the Department of Industrial Relations, Division of Apprenticeship Standards, 445 Golden Gate Avenue, San Francisco, California, and at COUNTY's Department of Public Works, and are available to Contractor and any other interested party upon request. Contractor shall post the prevailing rate of per diem wages to be posted at the Project site.

Article 18. APPRENTICES

- (a) Contractor agrees to comply with sections 1777.5, 1777.6 and 1777.7 of the California Labor Code relating to the employment of apprentices and to provide COUNTY with copies of any contract award information and verified statements of the journeyman and apprentice hours performed pursuant to this Agreement as required by section 1777.5(e). The responsibility for compliance with these provisions is fixed with Contractor for all apprenticeable occupations, where journeymen in the craft are employed on the public work, in a ratio of not less than one (1) apprentice for each five (5) journeymen (unless an exemption is granted in accordance with section 1777.5) and Contractor and its subcontractors shall not discriminate among otherwise qualified employees as indentured apprentices on any public work solely on the ground of race, religious creed, color, national origin, ancestry, sex, or age, except as provided in California Labor Code section 3077. Only apprentices, as defined in California Labor

Code section 3077, who are in training under apprenticeship standards and who have signed written apprentice agreements will be employed on public works in apprenticeable occupations. This section shall not be enforced if the not-to-exceed amount of this Agreement is less than thirty thousand dollars (\$30,000).

- (b) If the Project falls within the jurisdiction of California Labor Code section 1777.5, COUNTY shall, within five (5) days of the award, send a copy of the award to the Division of Apprenticeship Standards. In addition, COUNTY shall notify the Division of Apprenticeship Standards of a finding of any discrepancy regarding the ratio of apprentices to journeymen within five (5) days of the finding.

Article 19. HOURS OF WORK

Contractor agrees to comply with sections 1810 through 1815 of the California Labor Code and, when applicable, the Contract Work Hours and Safety Standards Act (40 USC §327 et seq.; 29 CFR Part 5) which provide that Contractor’s workers and its subcontractor’s workers may not be required or permitted to work more than eight (8) hours in any one (1) calendar day and forty (40) hours in any one (1) calendar week. Further, work performed by employees of Contractor or its subcontractor in excess of eight (8) hours per day, and forty (40) hours during any one (1) week, shall be compensated for all hours worked in excess of eight (8) hours per day at not less than one and one-half (1½) times the basic rate of pay. The responsibility for compliance with these provisions is fixed with Contractor. Contractor understands and agrees that it shall, as a penalty to COUNTY, forfeit specific monetary fines to COUNTY should Contractor or its subcontractors fail to comply with the provisions contained within this paragraph.

Article 20. INSURANCE COVERAGES

Contractor hereby agrees at its own cost and expense to procure and maintain, during the entire term of this Agreement and any extended term therefore, insurance in a sum acceptable to COUNTY and adequate to cover potential liabilities arising in connection with the performance of this Agreement and in any event not less than the minimum limit set forth as follows:

<u>INSURANCE</u>	<u>MINIMUM LIMIT</u>
<u>Worker’s Compensation, Coverage A</u>	Statutory
<u>Employers Liability, Coverage B</u>	\$1,000,000.00 per accident for bodily injury or disease
<u>Commercial General Liability Including Contractual Liability</u>	
Operations, Products and Completed Operations:	
Personal/Bodily Injury	\$1,000,000.00 / occurrence \$2,000,000.00 / aggregate
Property Damage	\$1,000,000.00 / occurrence \$2,000,000.00 / aggregate
<u>Commercial Automobile Liability (owned, hired, & non-owned vehicles)</u>	
Personal/Bodily Injury & Property Damage	\$1,000,000.00
Unemployment Insurance	To Be Determined by Scope of Work
Disability Insurance	To Be Determined by Scope of Work
Liability Insurance	To Be Determined by Scope of Work

Article 21. SPECIAL INSURANCE REQUIREMENTS

- (a) All insurance required under Article 20 shall:
- (1) Be procured from an insurer authorized to do business in California.
 - (2) Be primary coverage as respects COUNTY and any insurance or self-insurance maintained by COUNTY shall be in excess of Contractor's insurance coverage and shall not contribute to it.
 - (3) Name COUNTY as an additional insured on all policies, except Workers' Compensation, and provide that COUNTY may recover for any loss suffered by COUNTY by reason of Contractor's negligence.
 - (4) State that it is primary insurance and regards COUNTY as an additional insured and contains a cross-liability or severability of interest clause.
 - (5) Not be canceled, non-renewed, or reduced in scope of coverage until after thirty (30) days written notice has been given to COUNTY. However, Contractor may not terminate such coverage until it provides COUNTY with proof that equal or better insurance has been secured and is in place. Cancellation or change without the prior written consent of COUNTY shall, at the option of COUNTY, be grounds for termination of this Agreement.
- (b) Additional Insurance Requirements.
- (1) Complete copies of certificates of insurance for all required coverages including additional insured endorsements and thirty-day (30-day) notice of cancellation clause endorsements shall be attached hereto as Exhibit E and incorporated herein as though fully set forth.
 - (2) COUNTY is to be notified immediately of all insurance claims. COUNTY is also to be notified if any aggregate insurance limit is exceeded.
- (c) Nothing in this, or any other provision of this Agreement, shall be construed to preclude Contractor from obtaining and maintaining any additional insurance policies in addition to those required pursuant to this Agreement.

Article 22. INSURANCE ENDORSEMENTS, CLAUSES, & INFORMATION

- (a) The comprehensive/commercial general liability insurance shall contain a provision of endorsements stating that such insurance:
- (1) Includes contractual liability;
 - (2) Does not contain a "pro rata" provision which looks to limit the insurer's liability to the total proportion that its policy limits bear to the total coverage available to the insured;
 - (3) Does not contain an "excess only" clause which requires the exhaustion of other insurance prior to providing coverage;
 - (4) Does not contain an "escape clause" which extinguishes the insurer's liability if the loss is covered by other insurance;
 - (5) Includes COUNTY, architect, and the construction manager as an additional

insured;

- (6) States that it is primary insurance and regards COUNTY as an additional insured and contains a cross-liability or severability of interest clause; and
 - (7) Does not contain any exclusion as to loss or damage to property caused by explosion or resulting from collapse of buildings or structures or damage to property underground, commonly referred to by insurers as the "XCU Hazards."
- (b) Certificates and insurance policies shall include the following clause: "This policy shall not be canceled or reduced in required limits of liability or amount of insurance until notice has been mailed to COUNTY stating date of cancellation or reduction. Date of cancellation may not be less than thirty (30) days after date of mailing notice."
- (c) Certificates of insurance shall state, in particular, those insured, extent of insurance, location and operation to which insurance applies, expiration date, and cancellation and reduction notice.

Article 23. PROOF OF INSURANCE

Contractor shall not commence work nor shall it allow any subcontractor to commence work under this Agreement until Contractor has obtained all required insurance, certificates and endorsements, including but not limited to, Additional Insured Endorsements and thirty-days (30-days) Notice of Cancellation Clause endorsements have been delivered in duplicate to and approved by COUNTY. The above referenced insurance documents must be received by COUNTY on or before the effective date of this Agreement and shall be sent to the following addresses:

(i) County of Imperial
Risk Management Department
940 Main Street, Suite 101
El Centro, CA 92243

and

(ii) Department of Public Works
Attn: Director of Public Works
1002 State Street
El Centro, CA 92243

Article 24. CHOICE OF LAW

The laws of the State of California shall govern this Agreement. This Agreement is made and entered into in Imperial County, California. Any action brought by either Party with respect to this Agreement shall be brought in a court of competent jurisdiction within said County.

Article 25. PERMITS AND LICENSES

Permits and licenses necessary for prosecution of work shall be secured and paid for by Contractor, unless otherwise specified.

Article 26. EASEMENTS

Easements for permanent structures or permanent changes in existing facilities shall be secured and paid for by COUNTY, unless otherwise specified.

Article 27. SURVEYS

Surveys to determine location of property lines and corners will be supplied by COUNTY. Surveys to determine locations of construction, grading, and site work shall be provided by Contractor.

Article 28. EXCISE TAXES

If under federal excise tax law any transaction hereunder constitutes a sale on which a federal excise tax is imposed and the sale is exempt from such excise tax because it is a sale to a state or local government for its exclusive use, COUNTY, upon request, will execute a certificate of exemption which will certify: (a) that COUNTY is a political subdivision of the state for the purpose of such exemption; and (b) that the sale is for the exclusive use of COUNTY. No excise tax for such materials shall be included in any bid price.

Article 29. PATENTS AND ROYALTIES

Contractor shall hold and save COUNTY and its officers, agents, and employees harmless from liability of any nature or kind, including cost and expense, for or on account of any patented or unpatented invention, process, article, or appliance manufactured or used in the performance of this contract, including its use by COUNTY, unless otherwise specifically stipulated in the contract documents.

Article 30. MATERIALS

Except as otherwise specifically stated in this contract, Contractor shall provide and pay for all materials, labor, tools, equipment, water, light, power, transportation, superintendence, temporary constructions of every nature, and all other services and facilities of every nature whatsoever necessary to execute and complete this contract within the specified time.

Unless otherwise specified, all materials shall be new, and both workmanship and materials shall be of good quality.

Materials shall be furnished in ample quantities and at such times as to insure uninterrupted progress of work, and shall be stored properly and protected as required. Contractor shall be entirely responsible for damage or loss by weather or other causes to materials or work under this contract. No material, supplies, or equipment for work under this contract shall be purchased subject to any chattel mortgage or under a conditional sale or other agreement by which an interest herein or in any part thereof is retained by seller or supplier. Contractor warrants good title to all material, supplies, and equipment installed or incorporated in work, and agrees upon completion of all work to deliver premises, together with all improvements and appurtenances constructed or placed thereon by Contractor, to COUNTY free from any claims, liens, or charges. Contractor further agrees that neither Contractor nor any person, firm, or corporation furnishing materials or labor for any work covered by this contract shall have any right to lien upon premises or any improvement or appurtenance thereon, except that Contractor may install metering devices or other equipment of utility companies or of political subdivisions title to which is commonly retained by utility company or political subdivision. In event of installation of any such metering device or equipment, Contractor shall advise COUNTY as to owner thereof.

Nothing contained in this Article, however, shall defeat or impair the right of persons furnishing material or labor under any bond given by Contractor for their protection or any rights under any law permitting such persons to look to funds due Contractor in hands of COUNTY, and this provision shall be inserted in all subcontracts and material contracts, and notice of its provisions shall be given to all persons furnishing material for work when no formal contract is entered into for such material.

See Comprehensive Specifications for material requirements.

Article 31. SUBSTITUTIONS

Whenever specifications for any material, product, thing, service, or process is indicated or specified by grade, patent or propriety name or by name of manufacturer, such specifications shall be deemed to be used for the purpose of facilitating the description of material, product, thing, service, or process desired, and shall be deemed to be followed by the words "or equal", and Contractor may, unless otherwise stated, offer any material, product, thing, service or process which shall be equal or better in every respect to that so indicated or specified. If the material, product, thing, service, or process offered by Contractor is not, in the opinion of COUNTY and Architect/Engineer, equal or better in every respect to that specified, then Contractor shall furnish the material, product, thing, service, or process specified. The burden of proof as to equality of any material, product, thing, service, or process shall rest with Contractor. Contractor shall only be authorized to substitute any designated material, product, thing, service or process required under this contract if such request, together with substantiating data for substitution of an "or equal" item is timely submitted in accordance with the Calendar of Events set forth under section 19.3 of the "INFORMATION FOR BIDDERS" form and approval thereof is authorized in writing by COUNTY within the time frame set forth under Public Contract Code section 4104.5(a). Notwithstanding, in the event CONTRACTOR discovers after the stated substitution request filing deadline that a designated material, product, thing, service or process is no longer available and/or the use of the same is necessary to complete the project, CONTRACTOR may within thirty (30) days after award of the contract submit a "late substitution request", together with substantiating data for substitution of an "or equal" item for COUNTY's review and consideration. However, COUNTY shall have the sole discretion in granting such a late substitution request and shall not be required to accept the same even if the material, product, thing, service or process is equal or better in every respect.

It should be emphasized that a Contractor's request to substitute an "equal" material, product, thing or service for one designated in the contract specifications and/or COUNTY's subsequent written approval thereof, shall not in any way authorize an extension of time for performance of this contract. Moreover, in event Contractor furnishes a material, product, thing or service that is more expensive than that specified, the difference in cost of such material, product, thing, service or process, so furnished shall be borne solely by Contractor.

Article 32. SHOP DRAWINGS

Contractor shall check and verify all field measurements, and shall submit with such promptness as to cause no delay in Contractor's own work or in that of any other Contractor three (3) copies, checked and approved by Contractor, of all shop or setting drawings, schedules and materials lists required for the work of various trades.

Architect/Engineer shall check and approve within ten (10) working days such schedules and drawings only for conformance with design concept of project, and compliance with information given in contract documents. Contractor shall make any corrections required by Architect/Engineer; file with Architect/Engineer three (3) corrected copies, and furnish such other copies as may be needed for construction. Architect/Engineer's approval of such drawings or schedules shall not relieve Contractor from responsibility for deviations from drawings or specifications unless Contractor has in writing called Architect/Engineer's attention to such deviations at time of submission and secured Architect/Engineer's written approval, nor shall it relieve Contractor from responsibility for errors in shop drawings or schedule.

Article 33. SAMPLES

Contractor shall furnish for approval, within ten (10) days following award of contract, all samples as required in specifications together with catalogs and supporting data required by Architect/Engineer. This provision shall not authorize any extension of time for performance of this contract. Architect/Engineer will check and approve such samples, within five (5) working days from receipt of same, only for conformance with design concept of work and for compliance with information given in contract documents. Work shall be in accordance with approved samples.

Article 34. COST BREAKDOWN AND PERIODICAL ESTIMATES

Contractor shall furnish on forms provided by COUNTY:

- (a) Within ten (10) days of award of contract, a detailed estimate giving complete breakdown of contract price.
- (b) A periodical itemized estimate of work done for purpose of making partial payments thereon.
- (c) Within ten (10) days of request by COUNTY, a schedule of estimated monthly payments which shall be due Contractor under the contract.

Values employed in making up any of these schedules will be used only for determining basis of partial payments, and will not be considered as fixing a basis for additions to or deductions from contract price.

- (d) **Schedule of Values.** Prior to submitting the first application for payment, Contractor must prepare and submit to the County a schedule of values apportioned to the various divisions and phases of the Work, including mobilization and demobilization. If a Bid Schedule was submitted with Contractor's bid, the amounts in the schedule of values must be consistent with the Bid Schedule. Each line item contained in the schedule of values must be assigned a value such that the total of all items equals the Contract Price. The items must be sufficiently detailed to enable accurate evaluation of the percentage of completion claimed in each application for payment, and the assigned value consistent with any itemized or unit pricing submitted with Contractor's bid.

Article 35. PAYMENTS

- (a) Each month, within fifteen (15) days after receipt of approved periodical estimate for

partial payment, there shall be paid to Contractor a sum equal to ninety-five percent (95%) of value of work performed up to last day of previous month, less aggregate of previous payments. Monthly payments shall be made only on basis of monthly estimates which shall be prepared by Contractor on a form approved by COUNTY and filed before the fifth (5th) day of month during which payment is to be made. Work completed as estimated shall be an estimate only, and no inaccuracy or error in said estimate shall operate to release Contractor or any bondsman from damages arising from such work or from enforcing each and every provision of this contract, and COUNTY shall have the right subsequently to correct any error made in any estimate for payment. Contractor shall not be entitled to have any payment estimates processed or be entitled to have any payment made for work performed so long as any lawful or proper direction concerning work, or any portion thereof given by COUNTY or Architect, shall remain uncomplished with. The final payment of five percent (5%) of the value of work done under this contract, if unencumbered, shall be made thirty-five (35) days after acceptance of work by COUNTY. Acceptance will be made only by action of the Board of Supervisors in session. Acceptance by Contractor of said final payment shall constitute a waiver of all claims against COUNTY arising from this contract. At any time after fifty percent (50%) of the work has been completed, if COUNTY, by action of its governing body, finds that satisfactory progress is being made, COUNTY may make any of the remaining payments in full on actual work completed or may withhold any amount up to five percent (5%) thereof as COUNTY may find appropriate based on the Contractor's progress.

- (b) Contractor may elect to substitute or execute an escrow agreement (in the form prescribed by the Public Contracts Code) in place of retained funds held by COUNTY pursuant to Public Contract Code section 22300.
- (c) COUNTY shall pay interest at the legal rate set forth in Code of Civil Procedure 685.010 in the event payment is not made within thirty (30) days of an undisputed properly submitted request.

Article 36. PAYMENT WITHHELD

In addition to amount which COUNTY may retain under article entitled "Payments," COUNTY may withhold a sufficient amount of amounts of any payment or payments otherwise due to Contractor, as in COUNTY's judgment may be necessary to cover:

- (a) Payments which may be past due and payable for just claims against Contractor or any subcontractors for labor or materials furnished in and about the performance of work on the project under this contract.
- (b) Defective work not remedied.
- (c) Failure of Contractor to make proper payments to subcontractors or for material or labor.
- (d) Completion of contract, if there exists a reasonable doubt that contract can be completed for balance then unpaid.
- (e) Damage to another Contractor.

When the above grounds are removed, payment shall be made for amounts withheld because of them.

COUNTY may apply such withheld amount to payment of such claims or obligations at COUNTY's discretion. In so doing, COUNTY shall be deemed the agent of Contractor, and any payment so made by COUNTY shall be considered as a payment made under contract by COUNTY to Contractor, and COUNTY shall not be liable to Contractor for such payments made in good faith. Such payments may be made without prior judicial determination of claim or obligations. COUNTY will render Contractor a proper accounting of such funds disbursed on behalf of Contractor.

Article 37. CHANGES AND EXTRA WORK

All change orders shall be subject to the Public Contract Code, including but not limited to sections 20137 and 20142, *et seq.*

- (a) Change Orders. Contractor shall make no changes to the Work to be performed pursuant to this Agreement, including but not limited to additions, deletions, modifications or substitutions, nor shall Contractor perform any extra work (collectively, "Change Order Work") without the prior written consent of COUNTY. If Contractor encounters conditions it considers different from those described in Exhibit A to this Agreement, Contractor may request a change order in conformance with COUNTY's standard procedure ("Change Order"). If COUNTY approves the request, Contractor will execute a Change Order and Contractor's execution of the Change Order shall confirm approval thereof. COUNTY may order additional work, and Contractor shall perform such changes in the Work as directed by COUNTY in any Change Order prepared by Contractor. COUNTY's rights to eliminate portions of the Work or to initiate a Change Order shall not be limited in any way. The Change Order shall be in writing and shall include:
- (1) Any and all supporting documents and drawings depicting the source and location of the desired change, and explain in detail the field conditions and reasons for the requested change;
 - (2) Any change or adjustment to the compensation set forth in this Agreement in Article 3 as a result of changes in the Work based on a lump sum or time and material basis, as may be directed by COUNTY; and
 - (3) Any request for adjustments to time for completion of the Project.
- (b) Payment for Change Order Work. Contractor shall not be entitled to receive any compensation for work, labor, materials or changes of any kind, regardless of whether ordered by COUNTY or any of its representatives, unless a Change Order has been submitted in writing and approved prior to the commencement of any Change Order Work as described above. If the changes are required by any inspecting governmental agencies or utility companies, or are otherwise required to comply with any codes, laws, rules or regulations, including those set forth in this Agreement, then Contractor shall not be entitled to any increases in the compensation set forth in this Agreement at Article 3 or other compensation as a result of the changes.
- (c) Disputed Change Order Work. Any dispute concerning the performance of such Change

Order Work or the amount of compensation to be paid to Contractor by COUNTY shall not affect Contractor's obligation to perform such Change Order Work. Contractor agrees that it shall timely complete all Change Order Work even if there shall be a dispute between Contractor and COUNTY over the amount or scope of the Change Order Work. Contractor shall have the right to be compensated for any undisputed Change Order Work amounts as determined to be undisputed in COUNTY's sole discretion.

- (d) Authorized Representative. No Change Order shall be valid or binding against COUNTY unless such Change Order has been executed by COUNTY's designated representative, who is the Director of Public Works. COUNTY shall notify Contractor in writing if the designated representative is changed. The authority to execute a Change Order on this project shall not exceed the amount allowed by law pursuant to Government Code sections 20137-20142, *et seq.*

Article 38. DEDUCTIONS FOR UNCORRECTED WORK

If COUNTY deems it inexpedient to correct work injured or done not in accordance with contract, an equitable deduction from contract price shall be made therefore.

Article 39. PAYMENTS BY CONTRACTOR

Contractor shall pay:

- (a) For all transportation and utility services not later than the twentieth (20th) day of the calendar month following that in which such services are rendered;
- (b) For all materials, tools and other expendable equipment to the extent of ninety-five percent (95%) of cost thereof, not later than the twentieth (20th) day of the calendar month following that in which such materials, tools and equipment are delivered at site of project and balance of cost thereof not later than the thirtieth (30th) day following completion of that part of the work in or on which such materials, tools and equipment are incorporated or used; and
- (c) To each of Contractor's subcontractors, not later than the fifth (5th) day following each payment to Contractor; the respective amounts allowed Contractor on account of work performed by respective subcontractor to the extent of such subcontractor's interest therein.

Article 40. CONTRACTOR'S SUPERVISION

Unless personally present on premises where work is being done, Contractor shall keep on the work, during its progress, a competent superintendent satisfactory to COUNTY.

Contractor represents and warrants that any superintendent, employee, subcontractor and agent who will be performing any of the duties and obligations of Contractor herein possess all required licenses and authorities, as well as the experience, training, and communication skills to perform such tasks and communicate with the COUNTY and its representatives.

Superintendent shall not be changed except with consent of COUNTY unless superintendent proves to be unsatisfactory to Contractor and ceases to be in his employ.

Superintendent shall represent Contractor in Contractor's absence, and all directions given to superintendent shall be as binding as if given to Contractor. Other directions shall be so confirmed in written request in each case.

Contractor shall give efficient supervision to work, using Contractor's best skill and attention. Contractor shall carefully study and compare all drawings, specifications and other instructions, and shall at once report to Architect/Engineer any error, inconsistency or omission which Contractor may discover.

Article 41. INSPECTOR'S FIELD OFFICE

Contractor shall provide for use of COUNTY and its representative during construction working hours a temporary office of not less than seventy-five (75) square feet of floor area to be located as directed by COUNTY and its representative and to be maintained until removal is authorized by COUNTY and its representative. Office shall be of substantial waterproof construction with adequate natural light and ventilation by means of stock design windows. Door shall have a key, type walk, or padlock hasp.

A table satisfactory for study of plans and two chairs shall be provided by Contractor. Contractor shall provide and pay for adequate electric lights, local telephone service, and adequate air conditioning and heating for the field office until authorized removal.

Article 42. DOCUMENTS ON WORK

Contractor shall keep one copy of all contract documents, including addenda and change orders which are a part of contract documents, on job at all times. Said documents shall be kept in good order and available to Architect/Engineer representatives. Contractor shall be acquainted with and comply with all California Administrative Code provisions relating to this project, including, but not limited to, Title 19.

Article 43. UTILITIES AND RELOCATION

(a) All utilities, including, but not limited to, electricity, water, gas and telephone used on work, shall be furnished and paid for by Contractor. Contractor shall furnish and install necessary temporary distribution systems, including meters if necessary, from distribution points to points on site where utility is necessary to carry on the work. Upon completion of work, Contractor shall remove all temporary systems.

If contract is for addition to existing facility, Contractor may, with written permission of COUNTY, use COUNTY's existing utilities by making prearranged payments to COUNTY for utilities used by Contractor for construction.

(b) Contractor shall not be assessed damages for delay in completion of the project when such delay was caused by the failure of the awarding authority of this contract or the owner of the utility to provide for removal or relocation of the existing main or trunkline utility facilities; however, when the Contractor is aware that removal or relocation of an existing utility has not been provided for, Contractor shall promptly notify the awarding authority and the utility in writing, so that provision for such removal or relocation may be made to avoid and minimize any delay which might be caused by the failure to remove or relocate the main or trunk line utility facilities, or to provide for its removal or relocation.

In accordance with section 4215 of the Government Code, if the Contractor, while performing the contract, discovers any existing main or trunkline utility facilities not identified by the public agency in the contract plans or specifications, Contractor shall immediately notify the public agency and utility in writing. The public utility, where they are the owner, shall have the sole discretion to perform repairs or relocation work at a reasonable price. The Contractor shall be compensated for the costs of locating and repairing damage not due to the failure of the Contractor to exercise reasonable care, and removing or relocating such utility facilities not indicated in the plans and specification with reasonable accuracy and for equipment on the project necessarily idled during such work. Such compensation shall be in accordance with the extra work provisions set out at Article 37 hereof.

Article 44. SANITARY FACILITIES

Contractor shall provide a sanitary, temporary, portable toilet facility as directed by the COUNTY and its representative for the use of all workers. The building shall be maintained in a sanitary condition at all times, and shall be left at the site until removal is directed by the COUNTY and its representative.

Article 45. TRENCHES

(a) Trenching Requirements – Four Feet (4') Below the Surface. In the event the Project involves digging trenches or other excavations that extend deeper than four feet (4') below the surface, Contractor shall:

- (1) Promptly, and before the following conditions are disturbed, notify COUNTY, in writing, of any:
 - (A) Material that Contractor believes may be material that is hazardous waste, as defined in Health & Safety Code section 25117, that is required to be removed to a Class I, Class II, or Class III disposal site in accordance with provisions of existing law;
 - (B) Subsurface or latent physical conditions at the site differing from those indicated by information about the site made available to bidders prior to the deadline for submitting bids; and
 - (C) Unknown physical conditions at the site of any unusual nature, different materially from those ordinarily encountered and generally recognized as inherent in work of the character provided for in the Agreement.
- (2) In response to any written notice generated pursuant to paragraph (a) above, COUNTY shall promptly investigate the conditions, and if it finds that the conditions do materially so differ, or do involve hazardous waste, and cause a decrease or increase in Contractor's cost of, or the time required for, performance of any part of the Work, shall issue a change order under the procedures described in paragraph 37 of the General Conditions.
- (3) In the event that a dispute arises between COUNTY and Contractor whether the conditions materially differ, or involve hazardous waste, or cause a decrease or increase in Contractor's cost of, or time required for, performance of any part of the Work, Contractor shall not be excused from any scheduled completion date provided for by this Agreement, but shall proceed with all Work to be performed under this Agreement. Contractor shall retain any and all rights provided either

by contract or by law which pertain to the resolution of disputes and protests between the Parties.

- (b) Trenching Requirements – Project in Excess of Twenty-Five Thousand Dollars (\$25,000) and Five Feet (5') Below the Surface. For projects involving both an estimated expenditure in excess of twenty-five thousand dollars (\$25,000) and the excavation of any trench five feet (5') or more in depth, Contractor shall submit a detailed plan showing the design of shoring, bracing, sloping or other provisions to be made for worker protection from the hazard of caving ground during the excavation of such trench. The plan must be accepted by COUNTY (or by a registered civil or structural engineer, employed by COUNTY, to whom authority to accept has been delegated) in advance of excavation. If such plan varies from the shoring system standards, the plan shall be prepared by a registered civil or structural engineer. Nothing in this paragraph shall allow Contractor to use a shoring, sloping, or protective system less effective than that required by California Construction Safety Orders. Further, nothing in this paragraph shall be construed to impose tort liability on COUNTY or any of its employees.

Article 46. PROTECTION OF WORK AND PROPERTY

Contractor shall be responsible for all damages to persons or property that occur as a result of Contractor's fault or negligence in connection with the prosecution of this contract, and shall be responsible for the proper care and protection of all materials delivered and work performed until completion and final acceptance by COUNTY. All work shall be solely at Contractor's risk. Contractor shall adequately protect adjacent property from settlement or loss of lateral support as provided by law and contract documents. Contractor shall take all necessary precautions for safety of employees on the work, and shall comply with all applicable safety laws and building codes to prevent accidents or injury to persons on; about or adjacent to premises where work is being performed. Contractor shall erect and properly maintain, at all times, as required by conditions and progress of work, all necessary safeguards, signs, barriers, lights and watchmen for protection of workers and the public, and shall post danger signs warning against hazards created by such features in the course of construction. Contractor shall designate a responsible member of its organization on the work, whose duty shall be prevention of accidents. Name and position of person so designated shall be reported to COUNTY by Contractor.

In an emergency affecting safety of life or of work or of adjoining property, Contractor, without special instruction or authorization from COUNTY and its representative, is hereby permitted to act, at Contractor's discretion, to prevent such threatened loss or injury, and Contractor shall so act, without appeal, if so authorized or instructed by COUNTY and its representative. Any compensation claimed by Contractor on account of emergency work shall be determined by agreement.

Contractor shall provide such heat, covering, and enclosures as are necessary to protect all work, materials, equipment, appliances, and tools against damage by weather conditions. Contractor shall take adequate precautions to protect existing sidewalks, curbs, pavements, utilities, adjoining property and structures, and to avoid damage thereto, and repair any damage thereto caused by construction operations.

Contractor shall:

- (1) Enclose working area with a substantial dust reducing barrier and public safety barricade, and arrange work to cause minimum amount of inconvenience to public and COUNTY Staff in their regular business activities.
- (2) Provide substantial barricades around any shrubs or trees indicated to be preserved.
- (3) Deliver materials to building area over route designated by Architect.
- (4) When directed by COUNTY, take preventative measures to eliminate objectionable dust.
- (5) Confine Contractor's apparatus, the storage of materials, and the operations of workers to limits indicated by law, ordinances, permits or directions of Architect, and shall not unreasonably encumber premises with materials, and enforce all instructions of COUNTY and Architect regarding signs, advertising, fires, danger signals, barricades and smoking, and require that all persons employed on work comply with all regulations while on construction site. Hazardous materials of any kind are not allowed on site, without prior written approval from COUNTY.
- (6) Take care to prevent disturbing or covering any survey markers, monuments, or other devices marking property boundaries or corners. If such markers are disturbed by accident, they shall be replaced by an approved civil engineer at no cost to COUNTY.

Article 47. LAY OUT AND FIELD ENGINEERING

All field engineering required for laying out Contractor's work and establishing grades for earthwork operations shall be furnished by Contractor at Contractor's expenses. Such work shall be done by a qualified civil engineer approved by Architect/Engineer. Any required "As-Built" drawings of site development shall be prepared by the approved civil engineer.

Article 48. CUTTING AND PATCHING

Contractor shall do all cutting, fitting, or patching of work as required to make its several parts come together properly and fit it to receive or received by work of other Contractors showing upon, or reasonably implied by, the drawings and specifications for the completed structure, and Contractor shall make good after them as Architect/Engineer may direct. Contractor shall not endanger any work by cutting, excavating or otherwise altering work, and shall not cut or alter work of any other Contractor save with consent of Architect/Engineer.

Article 49. CLEANING UP

Contractor at all times shall keep premises free from debris such as waste, rubbish, and excess materials and equipment caused by work; debris shall be removed from premises. Contractor shall not leave debris under, in or about the premises. Upon completion of work, Contractor shall clean any areas where debris has collected. Contractor shall remove temporary fencing, barricades, and any temporary facilities from site.

Article 50. CORRECTION OF WORK

Contractor shall promptly remove from premises all work determined by COUNTY as failing to conform to contract, whether incorporated or not. Contractor shall promptly replace and re-execute his own work to comply with contract documents without additional expense to COUNTY, and shall bear the expense of making good all work of other Contractors destroyed or damaged by such removal or replacement.

If Contractor does not remove such work and materials within a reasonable time, fixed by written notice, COUNTY may remove the work and materials and may store the material at Contractor's expense. If Contractor does not pay expenses of such removal within ten (10) days' time thereafter, COUNTY may liquidate such work and materials upon private sale, and shall account for net proceeds thereof, after deducting all costs and expenses that should have been borne by Contractor.

Article 51. ACCESS TO WORK

COUNTY and its representative shall at all times have access to work wherever it is in preparation or progress. Contractor shall provide safe and proper facilities for such access so that COUNTY's representative may perform their functions under contract.

Article 52. OCCUPANCY

COUNTY reserves the right to occupy buildings at any time before completion, and such occupancy shall not constitute final acceptance of any part of work covered by this contract.

Article 53. COUNTY'S INSPECTOR

COUNTY may assign a representative to oversee work. Such representative shall have access to Inspector's Field Office and shall be fully informed of all progress and manner of work and character of materials. Representative shall have authority to stop work whenever provisions of the contract documents are not being complied with and Contractor shall instruct Contractor's employees accordingly.

All work shall be under observation of said COUNTY and its representative. Such personnel shall have free access to any or all parts of work at any time. Contractor shall furnish COUNTY and its representative reasonable facilities "Inspector's Field Office" for obtaining such information as may be necessary to keep COUNTY and its representative fully informed respecting progress and manner of work and character of materials. Inspection of work shall not relieve Contractor from any obligation to fulfill Contractor's contract. COUNTY and its representative shall have authority to stop work whenever provisions of contract documents are not being complied with, and Contractor shall instruct Contractor's employees accordingly.

Article 54. TESTS AND INSPECTIONS

If contract, COUNTY's instructions, laws, ordinances or any public authority require any work to be specially tested or approved, Contractor shall give notice in accordance with such authority of its readiness for observation or inspection at least two (2) working days prior to being tested or covered up. If inspection is by authority other than COUNTY, Contractor shall inform COUNTY of the date fixed for such inspection. Required certificates of inspection shall be secured by Contractor. Observations by COUNTY, its representative and other public authority shall be promptly made, and where practicable, at source of supply. If any work should be covered up without approval or consent of COUNTY, its representative and public authority, it must, if required by COUNTY, its

representative and public authority, be uncovered for examination and satisfactorily reconstruction at Contractor's expenses in compliance with contract.

Costs of tests of any material found to be not in compliance with contract shall be paid for by Contractor.

See Comprehensive Specifications for materials to be tested.

Where such inspection and testing are to be conducted by an independent laboratory or agency, such materials or samples of materials to be tested shall be selected by such laboratory or agency or COUNTY's representative, and not by Contractor.

Contractor shall notify COUNTY a sufficient time in advance of manufacture of materials to be supplied by Contractor under contract which must by terms of contract be tested, in order that COUNTY may arrange for testing of same at source of supply. Any materials shipped by Contractor from source of supply prior to having satisfactorily passed such testing and inspection, or prior to receipt of notice from said representative that such testing and inspection will not be required, shall not be incorporated in work without prior approval of COUNTY and subsequent testing and inspection.

Re-examination of questioned work may be ordered by COUNTY, and, if so ordered, work must be uncovered by Contractor. If such work be found in accordance with contract documents, COUNTY shall pay costs of re-examination and replacement. If such work be found not in accordance with contract documents, Contractor shall pay such costs.

Article 55. SOILS INVESTIGATION REPORT

When a soils investigation report obtained from test holes in site is available, such report shall not be part of this contract. Any information obtained from such report or any information given on drawings as to subsurface soil condition or to elevations of existing grades or elevations of underlying rock is approximate only and is not guaranteed, and does not form a part of the contract. Contractor is required to make a visual examination of site, and must make whatever tests Contractor deems appropriate to determine underground condition of soil. Contractor agrees that it will make no claim against COUNTY for damages in the event that, during progress of the work, Contractor encounters subsurface or latent conditions at site materially differing from those shown on drawings or indicated in specifications, or for unknown conditions of an unusual nature which differ materially from those ordinarily encountered and generally recognized as inherent in the work of the character provided for in plans and specifications.

Article 56. ARCHITECT/ENGINEER'S AND CONSTRUCTION MANAGER'S STATUS

The construction manager shall be COUNTY's representative during the construction period, and shall observe the progress and quality of the work on behalf of COUNTY. The construction manager shall have the authority to act on behalf of COUNTY only to the extent expressly provided in the contract documents. The construction manager shall have authority to stop work whenever such stoppage may be necessary in construction manager's reasonable opinion to insure the proper execution of the contracts.

The Architect/Engineer shall be, in the first instance, the judge of compliance with the design intent of the contract documents.

Article 57. INDEMNITIES

- (a) Contractor agrees to the fullest extent permitted by law to indemnify, defend, protect, and hold COUNTY and its representatives, officers, directors, designees, employees, agents, successors, and assigns harmless from any and all claims, expenses, liabilities, causes of action, demands, losses, penalties, attorney's fees and costs, in law or equity, of every kind and nature whatsoever arising out of or in connection with Contractor's negligent acts and omissions or willful misconduct under this Agreement ("Claims"), whether or not arising from the passive negligence of COUNTY, but does not include Claims that are finally determined to be the result of the sole negligence or willful misconduct of COUNTY.

- (b) Contractor agrees to defend with counsel acceptable to COUNTY, indemnify and hold COUNTY harmless from all Claims, including but not limited to:
 - (1) Personal injury, including but not limited to bodily injury, emotional injury, sickness or disease or death to persons including but not limited to COUNTY's representatives, officers, directors, designees, employees, agents, successors and assigns, subcontractors and other third parties and/or damage to property of anyone (including loss of use thereof) arising out of Contractor's negligent performance of, or willful misconduct surrounding, any of the terms contained in this Agreement, or anyone directly or indirectly employed by Contractor or anyone for whose acts Contractor may be liable;
 - (2) Liability arising from injuries to Contractor and/or any of Contractor's employees or agents arising out of Contractor's negligent performance of, or willful misconduct surrounding, any of the terms contained in this Agreement, or anyone directly or indirectly employed by Contractor or anyone for whose acts Contractor may be liable;
 - (3) Penalties imposed upon account of the violation of any law, order, citation, rule, regulation, standard, ordinance or statute caused by the negligent action or inaction, or willful misconduct of Contractor or anyone directly or indirectly employed by Contractor or anyone for whose acts Contractor may be liable;
 - (4) Infringement of any patent rights which may be brought against COUNTY arising out of Contractor's work;
 - (5) Any violation or infraction by Contractor of any law, order, citation, rule, regulation, standard, ordinance or statute in any way relating to the occupational health or safety of employees; and
 - (6) Any breach by Contractor of the terms, requirements or covenants of this Agreement.

- (c) The indemnification provisions of Paragraphs 57(b)(1) through 57(b)(6) above shall extend to Claims occurring after this Agreement is terminated, as well as while it is in force.

Article 58. PROVISIONS REQUIRED BY LAW DEEMED INSERTED

Each and every provision of law and clause required by law to be inserted in the contract shall be deemed to be inserted herein, and the contract shall be read and enforced as though it were included herein, and if, through mistake or otherwise, any such provision is not inserted, or is not correctly inserted, then upon application of either party, the contract

shall forthwith be physically amended to make such insertion or correction.

Article 59. LABOR - EMPLOYMENT SAFETY

Contractor shall maintain emergency first aid treatment for Contractor's employees which complies with the Federal Occupational Safety and Health Act of 1970 (29 U.S.C.A. 651, et seq.).

Article 60. NOTICE OF TAXABLE POSSESSORY INTEREST

The terms of this document may result in the creation of a possessory interest. If such a possessory interest is vested in a private party to this document, the private party may be subjected to the payment of personal property taxes levied on such interest.

Article 61. ASSIGNMENT OF UNFAIR BUSINESS PRACTICES CLAIMS (CLAYTON ACT AND CARTWRIGHT ACT)

Bidder shall comply with the following:

"In entering into a public works contract or a subcontract to supply goods, services or materials pursuant to a public works contract, the contractor or subcontractor offers and agrees to assign to the awarding body all rights, title and interest in and to all causes of action it may have under Section 4 of the Clayton Act (15 U.S.C. sec. 15) or under the Cartwright Act (Chapter 2 commencing with Section 16700) of Part 2 of Division 7 of the Business and Professions Code), arising from purchases of goods, services, or materials pursuant to the public works contract or the subcontract. This assignment shall be made and become effective at the time the awarding body tenders final payment to the contractor, without further acknowledgment by the parties." Cal Pub Contract Code § 7103.5(b)

Article 62. SUBSTITUTION OF SECURITY

Upon Contractor's request, COUNTY will make payment of funds withheld from progress payments to ensure performance under the contract pursuant to the requirements of California Public Contracts Code, section 22300, if the Contractor deposits in escrow with COUNTY, or with a bank acceptable to COUNTY, securities eligible for investment under Government Code section 16430 or bank savings and loan certificates of deposit, subject to the following conditions:

- (a) Contractor shall bear the expense of COUNTY and the escrow agent, and COUNTY and the bank, in connection with the escrow deposit made.
- (b) Securities or certificates of deposit to be placed in escrow shall be of a value at least equivalent to the amount of retention to be paid to the Contractor pursuant to this Article.
- (c) Contractor shall enter into an escrow agreement satisfactory to COUNTY, which agreement shall include provisions governing, inter alia:
 - (1) the amount of securities to be deposited,
 - (2) the providing of powers of attorney or other documents necessary for the transfer

- of the securities to be deposited,
- (3) conversion of cash to provide funds to meet defaults by Contractor including, but not limited to, termination of Contractor's control over the work, stop notice filed pursuant to law or other amounts to be kept or retained under the provisions of the contract,
 - (4) decrease in value of securities on deposit,
 - (5) the termination of the escrow upon completion of the contract.
- (d) Contractor shall obtain the written consent of the surety to such agreement.

Article 63. NON-DISCRIMINATION AND DISADVANTAGED BUSINESS ENTERPRISE PROGRAM

- (a) During the performance of this Agreement, Contractor and its subcontractors shall not unlawfully discriminate, harass or allow harassment against any employee or applicant for employment because of sex, race, color, ancestry, religious creed, national origin, physical disability (including HIV and AIDS), mental disability, medical condition (cancer), age (over forty (40)), marital status and denial of family care leave. Contractor and its subcontractors shall insure that the evaluation and treatment of their employees and applicants for employment are free from such discrimination and harassment. Contractor and its subcontractors shall comply with the provisions of the Fair Employment and Housing Act (Gov. Code section 12990 (a-f) *et seq.*) and the applicable regulations promulgated thereunder (California Code of Regulations, Title 2, Section 7285 *et seq.*). The applicable regulations of the Fair Employment and Housing Commission implementing Government Code section 12990 (a-f), set forth in Chapter 5 of Division 4 of Title 2 of the California Code of Regulations, are incorporated into this Agreement by reference and made a part hereof as if set forth in full. The applicable regulations of Section 504 of the Rehabilitation Act of 1973 (29 U.S.C. section 794 (a)) are incorporated into this Agreement by reference and made a part hereof as if set forth in full. Contractor and its subcontractors shall give written notice of their obligations under this clause to labor organizations with which they have a collective bargaining or other agreement. Contractor shall include the nondiscrimination and compliance provisions of this clause in all subcontracts to perform Work under this Agreement.
- (b) Contractor and its subcontractors shall reference and abide by the guidance and Disadvantaged Business Enterprise specifications contained in the California Department of Transportation's Local Programs Procedures 06-01 (which has been approved and released at <http://www.dot.ca.gov/> when working pursuant to this Agreement.

Article 64. SPECIAL CONDITIONS

- (a) The work shall be commenced on the date stated in COUNTY's *Notice to the Contractor to Proceed* which date will not be greater than ten (10) consecutive calendar days from and after the date of execution of the contract, and shall be completed within **sixty (60) working** days from and after the date stated in such notice. (See Article 2 of Agreement and Article 6 of General Conditions.)
- (b) The number of copies of drawings and specifications to be furnished to Contractor free of charge, per Article 3 of the *General Conditions* is three (3).

- (c) The number of executed copies of the *Agreement*, the *Performance Bond*, and the *Payment Bond* for the *Public Works* required is six (6).

Article 65. CONTRACT CONSTRUCTION

This contract has been reviewed by legal counsel for both COUNTY and Contractor, and no presumption or rule that ambiguities shall be construed against the drafting party shall apply to the interpretation or enforcement of this contract and/or any and all amendments thereto.

Article 66. COGNIZANCE OF VIOLATIONS BY COUNTY

- (a) Contractor understands and agrees that COUNTY shall take cognizance of violations of Chapter 1 of Part 7 of Division 2 of the California Labor Code committed in the course of the execution of this Agreement, and shall promptly report any suspected violations to the Labor Commissioner.
- (b) If COUNTY determines as a result of its own investigation that there has been a violation of Chapter 1 of Part 7 of Division 2 of the California Labor Code and withholds payment to Contractor, the procedures in California Labor Code section 1771.6 shall be followed.
- (c) COUNTY may bring an action in a court of competent jurisdiction to recover from Contractor the difference between the wages actually paid to an employee and the wages that were required to be paid to an employee pursuant to Chapter 1 of Part 7 of Division 2 of the California Labor Code, any penalties required to be paid pursuant to Chapter 1 of Part 7 of Division 2 of the California Labor Code, and costs and attorney's fees related to the action, if either of the following is true:
 - (1) COUNTY previously affirmatively represented to Contractor in writing, in the call for bids, or otherwise, that the Work was not a "public work," as defined in Chapter 1 of Part 7 of Division 2 of the California Labor Code; or
 - (2) COUNTY received actual written notice from the Department of Industrial Relations that the Work is a "public work," as defined in Chapter 1 of Part 7 of Division 2 of the California Labor Code, and failed to disclose that information to Contractor before the bid opening or award.

Article 67. LABOR STANDARDS COMPLIANCE REQUIREMENTS

- (a) It is Contractor's responsibility to provide all labor compliance documentation from its subcontractors completely and accurately in a timely manner. Contractor is responsible to review promptly and then forward on all required documentation to COUNTY per the time schedules in the Labor Compliance Handout. Included with the Labor Compliance Handout, COUNTY will provide training, documentation requirements, forms, etc., at the preconstruction conference or at a time designated by COUNTY.

For those Public Works Projects that are subject to the State Department of Industrial Relations (DIR), Division of Labor Standards Enforcement (DLSE) compliance monitoring and enforcement it is the Contractor's responsibility to submit certified

payroll records directly to the state Compliance Monitoring Unit (CMU). More information concerning state compliance can be found at <https://www.dir.ca.gov/Public-Works/publicworks.html>. The responsibility for compliance with these provisions is fixed with the Contractor.

- (b) In the event, during the review process of labor compliance documentation from COUNTY's labor compliance monitor, inaccurate, missing or incomplete information was provided, the labor compliance monitor will request from Contractor the items, revisions and documentation needed. The cost of this additional labor compliance enforcement shall be borne by Contractor.

Article 68. CONFLICT OF INTEREST AND GRATUITIES

- (a) Contractor agrees that it presently has no interest and shall not acquire any interest, direct or indirect, which could conflict in any manner or degree with the performance of services required to be performed under this Agreement. Contractor further agrees that in the performance of this Agreement, no person having any such interest shall be employed.
- (b) Contractor agrees to designate such person or persons who have responsibility for carrying out the services under this Agreement and that such person or persons as may be designated shall take any and all actions necessary to comply with COUNTY's Conflict of Interest Code adopted pursuant to California Government Code section 81000 to the extent required thereunder.
- (c) If it is found, after notice and hearing by COUNTY, that gratuities (in the form of entertainment, gifts, or otherwise) were offered or given by Contractor, or any agent or representative of Contractor, to any officer, employee or agent of COUNTY with a view toward securing a contract or securing favorable treatment with respect to the awarding or amending or the making of any determinations with respect to the performance of this Agreement, COUNTY may, by written notice to Contractor, terminate the right of Contractor to proceed under this Agreement and/or may pursue such other rights and remedies provided by law or under this Agreement.
- (d) In the event this Agreement is terminated as provided herein, COUNTY shall be entitled (1) to pursue the same remedies against Contractor as it could pursue in the event of a breach of the Agreement by Contractor, and (2) as a penalty in addition to any other damages to which it may be entitled by law, to exemplary damages in an amount (as determined by COUNTY) which shall be not less than three (3) nor more than ten (10) times the costs incurred by Contractor in providing any such gratuities to any such officer, employee or agent.

Article 69. FEDERAL CONTRACT REQUIREMENTS

- (a) Signage Requirements.
 - (1) Project Identity Signage. Contractor is required to provide and install the required project identity signage as detailed in the Plans and Specifications, in the size and at the location indicated by the Director of Public Works or his/her designee, and to maintain the signage in good condition for the duration of the Project. The signage may not be removed until the Notice of Completion is

recorded or by written direction of the Director of Public Works or his/her designee.

- (2) Required Employee Signage and Posters. Contractor is required to provide and install the Federal and State required employee posters and the required material pertaining to the required labor standards provisions are posted (including, but not limited to, WH-1321, OSHA 3165 and OFCCP-English, EFCCP-Spanish) at the worksite in a prominent and accessible place.
 - (3) Section 3 Compliant Signage. If required by COUNTY, Contractor is directed to provide and install the "Offer for Employment" signage as detailed in the Plans and Specifications in the size and at the location indicated by the Director of Public Works or his/her designee and to maintain the signage in good condition for the duration of the Project. The signage may not be removed until the Notice of Completion is recorded or by written direction of the Director of Public Works or his/her designee.
- (b) Housing And Urban Development Act Compliance. When applicable, Contractor agrees to comply with Section 3 of the Housing and Urban Development Act of 1968 (42 U.S.C. 3601 *et seq.*) which provides that to the greatest extent feasible, Contractor shall provide job training, employment and contracting opportunities for low- or very-low income residents in connection with the Project. The responsibility for compliance with these provisions is fixed with Contractor.
 - (c) Copeland "Anti-Kickback" Act Compliance. When applicable, Contractor agrees to comply with the Copeland Act (18 USC §874 and 40 USC §276c; 29 CFR Part 3) which precludes Contractor and its subcontractors from in any way inducing an employee to give up any part of the compensation to which he or she is entitled under his or her contract of employment. Contractor and its subcontractors shall submit a weekly statement of the wages paid to each employee performing on covered work during the preceding payroll period. Contractor understands and agrees that should Contractor its subcontractors induce an employee working on a covered contract to give up any part of the compensation to which he or she is entitled, the inducing party may be subject to a five thousand dollar (\$5,000) fine, or imprisonment for up to five (5) years, or both. Contractor also understands and agrees that willful falsification of the statement of compliance may subject the employer to civil or criminal prosecution and may be cause for contract termination or debarment. The responsibility for compliance with these provisions is fixed with Contractor.
 - (d) Fair Labor Standards Act Compliance. When applicable, Contractor agrees to comply with the Fair Labor Standards Act of 1938 as amended (29 U.S.C. 201 *et seq.*) which establishes minimum wage, overtime pay, recordkeeping, and youth employment standards affecting full-time and part-time workers on the Project. The responsibility for compliance with these provisions is fixed with Contractor.
 - (e) Certification Regarding Debarment, Suspension and Other Responsibility Matters. When applicable, Contractor agrees to execute a certification regarding debarment, suspension and other responsibility matters. The responsibility for compliance with

this provision is fixed with Contractor.

- (f) Federal Equal Employment Opportunity Construction Contract Specifications. When applicable, Contractor agrees to incorporate the notice set forth in paragraph (d) of 41 C.F.R. 60-4.2 relating to the “Equal Opportunity Clause” and the “Standard Federal Equal Employment Specifications.” The responsibility for compliance with this provision is fixed with Contractor.
- (g) Clean Air Act and the Federal Water Pollution Control Act. When applicable, Contractor agrees to comply with all applicable standards, orders or regulations issued pursuant to the Clean Air Act (42 U.S.C. 7401 *et seq.*), the Federal Water Pollution Control Act as amended (33 U.S.C. 1251 *et seq.*), Presidential Executive Order 11738 and Environmental Protection Agency regulations set forth at 40 C.F.R. Part 15. Contractor understands and agrees that violations shall be reported to the Federal awarding agency and the Regional Office of the Environmental Protection Agency. The responsibility for compliance with these provisions is fixed with Contractor.
- (h) Prohibition on the Use of Federal Funds for Lobbying. When applicable, Contractor shall file the required certification. Each tier certifies to the tier above that it will not and has not used Federal appropriated funds to pay any person or organization for influencing or attempting to influence an officer or employee of any agency, a member of Congress, officer or employee of Congress, or an employee of a member of Congress in connection with obtaining any Federal contract, grant or any other award covered by 31 U.S.C. 1352. Each tier shall also disclose any lobbying with non-Federal funds that takes place in connection with obtaining any Federal award. Such disclosures are forwarded from tier to tier up to the recipient. The responsibility for compliance with this provision is fixed with Contractor.
- (i) Federal Employment Eligibility Verification. Contractor shall verify name, date of birth and social security number, along with immigration information for non-citizens in order to verify the identity and employment eligibility of both citizen and non-citizen new hires. The responsibility for compliance with this provision is fixed with Contractor.
- (j) The Civil Rights, HCD and Age Discrimination Act Assurances. During the performance of this Agreement, Contractor assures that no otherwise qualified person shall be excluded from participation or employment, denied program benefits or be subjected to discrimination based on race, color, national origin, gender, age or handicap, under any program or activity funded by this Agreement, as required by Title VI of the Civil Rights Act of 1964, Title I of the Housing and Community Development Act of 1974, as amended, and the Age Discrimination Act of 1975, and all implementing regulations. The responsibility for compliance with these provisions is fixed with Contractor.
- (k) Standard Equal Opportunity Clause.
 - (1) Contractor hereby agrees that it will incorporate or cause to be incorporated into any contract for construction work, or modification thereof, as defined in the regulations of the Secretary of Labor at 41 CFR Chapter 60, which is paid for in

whole or in part with funds obtained from the Federal Government or borrowed on the credit of the Federal Government pursuant to a grant, contract, loan insurance, or guarantee, or undertaken pursuant to any Federal program involving such grant, contract, loan, insurance, or guarantee, the following equal opportunity clause:

“During the performance of this contract, the Contractor agrees as follows:

- (A) The Contractor will not discriminate against any employee or applicant for employment because of race, color, religion, sex, national origin or disabilities. The Contractor will take affirmative action to ensure that applicants are employed, and that employees are treated during employment without regard to their race, color, religion, sex, or national origin. Such action shall include, but not be limited to, the following: employment, upgrading, demotion or transfer; recruitment or recruitment advertising; layoff or termination; rates of pay or other forms of compensation; and selection for training, including apprenticeship. The Contractor agrees to post in conspicuous places, available to employees and applicants for employment, notices to be provided setting forth the provisions of this nondiscrimination clause.
- (B) The Contractor will, in all solicitations or advertisements for employees placed by or on behalf of the Contractor, state that all qualified applicants will receive consideration for employment without regard to race, color, religion, sex, national origin or disabilities.
- (C) The Contractor will send to each labor union or representative of workers with which the Contractor has a collective bargaining agreement or other contract or understanding, a notice to be provided advising the said labor union or workers' representatives of the Contractor's commitments under this section, and shall post copies of the notice in conspicuous places available to employees and applicants for employment.
- (D) The Contractor will comply with all provisions of Executive Order 11246 of September 24, 1965, and of the rules, regulations, and relevant orders of the Secretary of Labor.
- (E) The Contractor will furnish all information and reports required by Executive Order 11246 of September 24, 1965, and by rules, regulations, and orders of the Secretary of Labor, or pursuant thereto, and will permit access to its books, records, and accounts by the administering agency and the Secretary of Labor for purposes of investigation to ascertain compliance with such rules, regulations, and orders.
- (F) In the event of the Contractor's noncompliance with the discrimination clauses of this contract or with any of the said rules, regulations, or orders, this contract may be canceled, terminated, or suspended in whole or in part and the Contractor may be declared ineligible for further

government contracts or federally assisted construction contracts in accordance with procedures authorized in Executive Order 11246 of September 24, 1965, and such other sanctions may be imposed and remedies invoked as provided in Executive Order 11246 of September 24, 1965, or by rules, regulations, or orders of the Secretary of Labor, or as otherwise provided by law.

- (G) The Contractor will include the portion of the sentence immediately preceding paragraph "1" and the provisions of paragraphs "1" through "7" in every contract or purchase order unless exempted by rules, regulations, or orders of the Secretary of Labor issued pursuant to Section 504 of Executive Order 11246 of September 24, 1965, so that such provisions will be binding upon each contractor or vendor. The Contractor will take such action with respect to any contract or purchase order as the administering agency may direct as a means of enforcing such provisions, including sanctions for noncompliance; provided, however, that in the event a Contractor becomes involved in, or is threatened with, litigation with a contractor or vendor as a result of such direction by the administering agency, the Contractor may request the United States to enter into such litigation to protect the interests of the United States."
- (1) Contractor further agrees that it will be bound by the above equal opportunity clause with respect to its own employment practices when it participates in federally-assisted construction work; provided that if Contractor so participating is a State or local government, the above equal opportunity clause is not applicable to any agency, instrumentality, or subdivision of such government which does not participate in work on or under the Agreement.
- (2) Contractor agrees that it will assist and cooperate actively with the administering agency and the Secretary of Labor in obtaining the compliance of Contractors and subcontractors with the equal opportunity clause and the rules, regulations, and relevant orders of the Secretary of Labor, that it will furnish the Department and HUD and the Secretary of Labor such information as they may require for the supervision of such compliance, and that it will otherwise assist the administering agency in the discharge of the agency's primary responsibility for securing compliance.
- (3) Contractor further agrees that it will refrain from entering into any contract or contract modification subject to Executive Order 11246 of September 24, 1965, with a contractor debarred from, or who has not demonstrated eligibility for, government contracts and federally-assisted construction contracts, pursuant to the Executive Order and will carry out such sanctions and penalties for violation of the equal opportunity clause as may be imposed upon contractors and subcontractors by the administering agency or the Secretary of Labor pursuant to Part II, Subpart D of the Executive Order. In addition, Contractor agrees that if it fails or refuses to comply with these undertakings, COUNTY may take any or all of the following actions:

Cancel, terminate, or suspend in whole or in part this funding commitment (contract, loan, grant, insurance, guarantee); refrain from extending any further assistance to the applicant under the program with respect to which the failure or refund occurred until satisfactory assurance of future compliance has been received from such Contractor; and refer the case to the Department of Justice for appropriate legal proceedings.

Article 70. INELIGIBILITY

If the Bidder has been deemed ineligible to perform work on public works projects pursuant to Labor Code Sections 1777.1 or 1777.7, then it shall be prohibited from bidding on, being awarded a contract for, or performing work as a subcontractor on this project, or any other public works project within the state of California.

Article 71. RESOLUTION OF CLAIMS

- (a) Compliance with all change order procedures is a prerequisite to filing a Public Contract Code Claim pursuant to this Section. Claims must be submitted no later than (a) 30 days after the dispute resolution process set forth in Section 5-1.43 is complete or (b) 30 days after the occurrence of the event giving rise to the claim.
- (b) In accordance with the procedures set forth in Public Contract Code Sections 9204 and 20104-20104.6, a Contractor may submit a claim by registered or certified mail with return receipt requested for one or more of the following: (a) a time extension, including, without limitation, for relief from damages or penalties for delay assessed by the County; (b) payment by the County of money or damages arising from work done by, or on behalf of, the Contractor pursuant to this contract and payment for which is not otherwise expressly provided or to which the Contractor is not otherwise entitled; or (c) payment of an amount that is disputed by the County.
- (c) The Contractor shall furnish reasonable documentation to support the claim, including, but not limited to: 1) a clear concise recital of the basis upon which the claim is asserted, including a designation of the provisions of the Contract upon which the claim is based. 2) a statement as to the amount of time and/or compensation sought pursuant to the claim; 3) whether the Contractor's claim arises from an ongoing occurrence, and if so a description of the specific work activities affected by the claim, 4) a time impact analysis in the event that Contractor request a time extension, 5) full and complete cost records supporting the amount of any claim for additional compensation, and 6) a notarized certification by the Contractor as follows: "Under the penalty of law for perjury or falsification and with specific reference to the California False Claims Act. Government Code Section 12650 et seq. The undersigned hereby certifies that the information contained herein is a true, accurate and complete statement of all features relating to the claim asserted." Failure by the Contractor to provide sufficient documentation will result in denial of the claim. The County reserves the right to request additional documentation, or clarification of the documentation provided.
- (d) Upon receipt of a claim, the County will conduct a reasonable review and provide a written statement to the Contractor identifying what portion of the claim is disputed and what portion is undisputed within 45 days of receipt of the claim. The County and Contractor may, by mutual agreement, extend the 45 day time period. For any

undisputed portion of a claim, the County must make payment within 60 days of its issuance of the written statement.

- (e) If the Contractor disputes the County's written statement, or if the County fails to respond, the Contractor may demand an informal conference to meet and confer for the settlement of the issues in dispute. The County will then schedule the meet and confer conference within 30 days of the demand. Within 10 business days following the meet and confer conference. The County will provide a written statement identifying the portion of the claim that remain in dispute. Any payment due on an undisputed portion of the claim will be made within 60 days of the meet and confer conference.
- (f) After the meet and confer conference, any disputed portion of the claim shall be submitted to non-binding mediation. Alternatively, upon receipt of a claim, the parties may mutually agree to waive in writing, mediation and proceed directly to the commencement of a civil action or binding arbitration as applicable, if mediation is unsuccessful, the parts of the claim that remain in dispute shall be subject to applicable procedures set forth below.
- (g) Failure of a public entity to respond to a claim within the time periods described above shall result in the claim being deemed rejected in its entirety. Additionally amounts not paid in a timely manner shall bear interest at 7 percent per year.
- (h) In the event that the mediation is unsuccessful, Contractor must file a government claim pursuant to Government Code Sections 910 et seq. in order to initiate a civil action.
- (i) In any civil action filed to resolve claims, the court shall submit the matter to nonbinding mediation within 60 days following the filing or responsive pleading provided that the parties have not already participated in mediation of the claim as outlined above. If the matter remains in dispute after nonbinding mediation, the court shall submit the matter to judicial arbitration pursuant to the Code of Civil Procedure Section 1141.10 et. seq. If the matter remains in dispute after judicial arbitration, the County or the Contractor may request a trial de novo.

Article 72. MISCELLANEOUS

- (a) Entire Agreement. This Agreement contains the entire agreement between COUNTY and Contractor relating to the transactions contemplated hereby and supersedes all prior or contemporaneous agreements, understandings, provisions, negotiations, representations, or statements, either written or verbal.
- (b) Assignment. Neither this Agreement nor any duties or obligations hereunder shall be assignable by Contractor without the prior written consent of COUNTY.
- (c) Modification. No modification, waiver, amendment, discharge, or change of this Agreement shall be valid unless the same is in writing and signed by the Party against whom the enforcement of such modification, waiver, amendment, discharge, or change is or may be sought.

- (d) Captions. Captions in this Agreement are inserted for convenience of reference only and do not define, describe, or limit the scope or the intent of this Agreement or any of the terms thereof.
- (e) Partial Invalidity. If any provision in this Agreement is held by a court of competent jurisdiction to be invalid, void, or unenforceable, the remaining provisions will nevertheless continue in full force without being impaired or invalidated in any way.
- (f) Gender and Interpretation of Terms and Provisions. As used in this Agreement and whenever required by the context thereof, each number, both singular and plural, shall include all numbers, and each gender shall include a gender. Contractor as used in this Agreement or in any other document referred to in or made a part of this Agreement shall likewise include singular and the plural, a corporation, a partnership, individual, firm, or person acting in any fiduciary capacity as executor, administrator, trustee or in any other representative capacity or any other entity. All covenants herein contained on the part of Contractor shall be joint and several if more than one person, firm or entity executes this Agreement.
- (g) Waiver. No waiver of any breach or of any of the covenants or conditions of this Agreement shall be construed to be a waiver of any other breach or to be consent to any further or succeeding breach of the same or any other covenant or condition.
- (h) Attorneys' Fees and Costs. If either Party herein brings an action to enforce the terms thereof or to declare rights hereunder, the prevailing Party in any such action, on trial or appeal, shall be entitled to reasonable attorneys' fees as fixed by the court and actual costs to be paid by the losing Party.
- (i) Authority.
 - (1) Each individual executing this Agreement on behalf of Contractor represents and warrants that:
 - (A) He/She is duly authorized to execute and deliver this Agreement on behalf of Contractor;
 - (B) Such execution and delivery is in accordance with the terms of the Articles of Incorporation or Partnership, any by-laws or Resolutions of Contractor and;
 - (C) This Agreement is binding upon Contractor in accordance with its terms.
 - (2) Contractor shall deliver to COUNTY evidence acceptable to COUNTY of the foregoing within thirty days of execution of this Agreement.
- (j) Counterparts. This Agreement may be executed in counterparts.
- (k) Review of Agreement Terms. This Agreement has been reviewed and revised by legal counsel for both COUNTY and Contractor, and no presumption or rule that ambiguities shall be construed against the drafting Party shall apply to the interpretation or enforcement of the same or any subsequent amendments thereto.

EXHIBIT A

GENERAL SPECIFICATIONS

**IMPERIAL COUNTY
DESERT SHORES SOCCER PARK
PHASE 1
57 PALM DRIVE, DESERT SHORES, CA 92274**

COUNTY PROJECT NO. SR53009

LAWS AND REGULATIONS

Contractor shall comply with all applicable and current local, state, and federal laws, guidelines, standards, and California building codes.

SCHEDULE

Monday to Friday between 7:00 AM to 4:00 PM per Article 19. Hours of Work

PROJECT DESCRIPTION

The project consists of landscape and irrigation installation and all other facilities and incidentals necessary to complete the improvements as required by the project specifications, and other provisions of the contract. All the above improvements are to be constructed in a workmanlike manner, leaving the entire project in a neat and presentable condition. Refer to Section 4000 for more information.

UNDERGROUND FACILITIES

The contractor is responsible for coordinating all project documentation, including but not necessarily limited to, the Contract Documents and existing record drawings for the determination of the location of all underground facilities.

The Contractor shall exercise care in all excavations to avoid damage to existing underground facilities. This shall include potholing or hand digging in those areas where underground facilities are known to exist until they have been sufficiently located to avoid damage to the facilities.

Prior to fabrication, the Contractor shall verify the location and elevations of existing underground facilities, which the Contractor is connecting to.

No additional compensation shall be provided to the Contractor for compliance with the provisions of this section or for the damage.

SECTION 4000
DIVISION 4 - TECHNICAL SPECIFICATIONS

1.0 GENERAL REQUIREMENTS

The Standard Specifications as defined in Section 2000 shall govern the work for this project. All language in the Standard Specifications shall remain in full force and effect, unless the language in the prevailing Contract Document specifically cites the section number in the Standard Specification and says said provision is in lieu of that Standard Specification section.

The project drawings and details are considered as part of these specifications, and any work or materials shown on the drawings and not mentioned in the specifications, or via versa, are executed as if specifically mentioned in both.

2.0 MOBILIZATION (BAE BID ITEM NO. 1)

Mobilization shall conform to the provisions in Section 7-3.4, "Mobilization" of the Standard Specifications. Mobilization includes expenditures for all preparatory work and operations, including but not limited to, those costs necessary for the movement of personnel, equipment, supplies, and incidental to the project site; for the establishment of all facilities necessary for work on the project; and for all other work and operations which must be performed or costs incurred prior to beginning work on the various contract items on the project site as well as the related demobilization costs anticipated at the completion of the project.

Mobilization shall be paid for at the Contract **Lump Sum** Price as shown on the Bid Schedule. Fifty percent (50%) of the lump sum price will be paid upon successful move in and completion of mobilization. The remaining fifty percent (50%) shall be paid after the contractor is completely demobilized and all project sites have satisfactorily been restored and the project cleanup is completed.

3.0 DUST CONTROL (BASE BID ITEM NO. 2 / ALT BID ITEM NO. 1)

Dust Control shall comply with Section 3000-4.2.

Dust Control shall be paid for at the Contract **Lump Sum** Price as shown on the bid schedule. Monthly payments will be made on a pro-rata basis.

4.0. LANDSCAPE AND IRRIGATION (BASE BID ITEMS NO. 3-6/ ALT BID ITEMS NO. 3-5)

Landscape and irrigation shall conform with Section 800 "Landscape and Irrigation Materials," and Section 801 "Landscape and Irrigation Installation," of the Standard Specifications and these Special Provisions.

800-1 LANDSCAPE MATERIALS

Material lists and submittals to be approved by District.

800-1.2.3 Commercial Fertilizer [add the following]

Refer to Waypoint Analytical soils analysis report for appropriate soil fertilization.

800-1.2.4 Organic Soil Amendments

Specified as Type 1. Refer to Waypoint Analytical soils analysis report for appropriate soil amendments.

800-1.4 Plants.

800-1.4.5 Sod and Stolons (turf grass). [Add the following]

Grassed areas must be over seeded with rye grass if planted/installed in the winter season (commencing in October). Repair all disturbed turf areas prior to final acceptance with sod or stolons directed by the District.

800-1.6 Certification and Submittals. [Add subsection]

The following written certifications are required to be submitted to the District upon delivery of the respective materials to the job site:

- a) Total quantity of commercial fertilizers by type
- b) Total quantity of organic mulch
- c) Total quantity of sod

All submitted products may only be used when approved by the District. Substitution of materials must receive prior, written authorization from the District before delivery to the site.

800-2 IRRIGATION SYSTEM MATERIALS

800 -2.1 Pipe and Fittings.

800-2.1.1 General. [Add the following]

Irrigation lateral and pressure lines shall be placed in Schedule 40 PVC pipe sleeve two times the pipe size where occurs under streets or paving and as directed by the District.

800-2.1.3 Plastic Pipe for use with Solvent Weld Socket or Threaded Fittings. [Add the following]

All pipe 2.5" and smaller shall be Schedule 40 PVC Type 1, Grade 1 pipe. All pipe 3" and larger shall be Class 315 PVC Type 1, Grade 1 pipe. All plastic pipes will bear the following markings: the manufacturer's name, nominal pipe size or schedules.

Main Line Fittings will be solvent welded shall be standard weight schedule 80 with molded threads.

800-3.3 Controller Unit. [Add the following]

The ESP-LXMEF-IQ NCC-SS Controller with Radio Modem shall be of a hybrid type that combines electro-mechanical and micro-electronic circuitry capable of fully automatic or manual operation. The controller shall be housed in a wall-mountable, weather-resistant stainless steel cabinet with a key-locking cabinet door suitable for outdoor installation. Refer to plans for model number. The controller shall have the ability to be programmed and operated in any one of six languages: English, Spanish, French, German, Italian, and Portuguese. The display shall show programming options and operating instructions in the chosen language without altering the programming or operation information.

The controller shall have a base station capacity of 32 stations with two additional expansion

slots capable of receiving ESP-LXMEF 32 station modules to create a controller capacity. All stations shall have the capability of independently obeying or ignoring any weather sensor as well as using or not using the master valves. Station timing shall be from 0 minutes to 12 hours. The controller shall have a Seasonal Adjustment by program which adjusts the station run time from 0 to 300% in 1% increments. The controller shall also have a Monthly Seasonal Adjustment of 0 to 300% by month. Station timing with Seasonal Adjustment shall be from 1 second to 16 hours.

The controller shall have 4 separate and independent programs which can have different start times, start day cycles, and station run times. Each program shall have up to 8 start times per day for a total of 32 possible start times per day. The 4 programs shall be allowed to overlap operation based on user-defined settings which control the number of simultaneous stations per program and total for the controller. The controller shall allow up to 8 valves to operate simultaneously per program and total for the controller including the master valves.

The controller shall have a 365-day calendar with Permanent Day Off feature that allows a day(s) of the week to be turned off on any user selected program day cycle. (Custom, Even, Odd, Odd31, & Cyclical). Days set to Permanent Day Off shall override the normal repeating schedule and not water on the specified day(s) of the week. The controller shall also have a Calendar Day Off feature allowing the user to select up to 5 dates up to 365-days in the future when the controller shall not start programs. The controller shall incorporate a Rain Delay feature allowing the user to set the number of days the controller should remain off before automatically returning to the auto mode.

The controller shall have Cycle+Soak water management software which is capable of operating each station for a maximum cycle time and a minimum soak time to reduce water run-off. The maximum cycle time shall not extend by Seasonal Adjustment.

The controller shall incorporate a Flow Smart Module feature providing real-time flow, power, and station management. Flow Smart Module shall manage the number of stations operating at any point in time based on water source capacity, station flow rate, number of valves per station; user-defined simultaneous stations per program and for the controller. The controller shall provide station priorities to determine the order in which stations shall operate. The controller shall ignore the station number and instead operate the highest priority stations first and the lower priority stations last.

The controller shall offer Water Windows for each program. This function sets the allowed start and stop time where watering is allowed. If the watering cannot be completed by the time the Water Window closes, the stations with remaining run time are paused and watering automatically resumes when the Water Window opens the next time.

A Flow Smart Module Learn Flow Utility which learns the normal flow rate of each station shall be included. Each time a station runs Flow Smart Module compares the current real-time flow rate to the learned rate and takes user-defined actions if high flow, low flow, or no flow is detected. Flow Smart Module shall automatically determine the location of the flow problem and isolate the problem by turning off the affected station(s) or master valve(s). Flow Smart Module shall be compatible with both normally closed and open master valves. A Manual Master Valve Water Window shall be provided to coordinate daytime manual watering with the flow sensing. This Water Window shall offer programmable days of the week and manual watering additional flow rate.

801 LANDSCAPE AND IRRIGATION INSTALLATION

801-1 General [Add the following]

Landscape and irrigation installation shall conform to the provisions of Section 801 of the Standard Specifications and their provisions.

Contractor shall have appropriate licenses, bonds, and insurance.

The Contractor shall visit the construction site and shall take all measurements and obtain any other information as may be necessary for a complete and conclusive bid.

The work required is indicated on the drawings and includes but is not necessarily limited to: soil preparation, installing irrigation system, placing/laying sod, weed control, and 90-day plant establishment period including guaranteeing sod and/or replacing sod.

Landscape and irrigation workmanship and materials shall be of the highest standards and quality.

All landscape materials and installations will be guaranteed against any and all poor, inadequate or inferior materials and/or workmanship for a period of not less than 90 days. During the guarantee period, any material found to be dead, missing, or in poor condition will be replaced by the Contractor within five (5) days of written notification. The District's representative will be the sole judge as to the condition of the material. Replacement will be made in accordance with these specifications and the plans. Material and labor involved in replacing plant material will be provided by the Contract at no expense.

801-1.1 Inspections. [Add subsection]

Inspections ensure compliance with the drawings and specifications. The Contractor will contact the District's representative at least 48 hours (two working days) in advance of each inspection. An inspection is required at each of the following steps including but not limited to:

- a) Inspection of fine grade.
- b) Acceptance of organic mulch and taking of soil samples.
- c) Inspection of soil amendment work.
- d) Inspection of sod and upon delivery to the project site.
- e) Irrigation pressure test prior to backfill of trench.
- f) Irrigation coverage test.
- g) Irrigation main lines, valves, laterals, and wires before backfill or during irrigation installation.
- h) Layout of planting prior to installation.
- i) At the start of the establishment period.
- j) At the end of the establishment period, after final acceptance prior to maintenance period of the project. Project acceptance will be confirmed in writing.

The Contractor is required to notify the District of work activity to be inspected. Give at least 48 hours' notice for all work. No work will proceed until the District has inspected and verbally approved the work activity.

801-1.2 Soil Testing. [Add subsection]

Refer to plans for Waypoint Analytics soils analysis for fertility of soil and required nutrient needs.

801-2 EARTHWORK AND TOPSOIL PLACEMENT.

801-2.1 General. [Add the following]

All grading, mounding and all weed control measures shall be completed prior to irrigation and planting. Should 30 calendar days elapse between completion of soil preparation and commencement of planting, all areas will be prepared again.

Remove rocks, sticks, grass and other undesirable objects unsuitable to plants.

801-2.2.2 Fertilizers and Conditioning Procedures. [Add the following]

Fertilizers will be applied according to the manufacturer's recommendation.

801-2.3 Finished Grading. [Add the following]

All landscape areas will be graded to finish grades, reestablishing flow lines as approved prior to amending the soil. Finish grades will be inspected upon completion. The contractor will not proceed with planting work until finish grades have been inspected and accepted by the District.

801-2.4 Weed Control Measures. [Add the subsection]

Apply a translocated herbicide and allow sufficient time to completely kill off all germinated weeds; herbicide to be reapplied as needed to completely eradicate all germinated weeds. Weed control shall be to the satisfaction of the District. Refer to plans.

801-4 PLANTING.

801-4.1 General. [Add the following]

All planting holes shall be pre-soaked and backfill shall be as recommended by the soil test report.

801-4.8.3 Sod. [Add the following]

Irrigate areas to be sodded prior to installation of sod. Soil shall be damp to a depth of 2".

Time limit and option in first paragraph below are requirements of TPI's "Guideline Specifications to Turfgrass Sodding."

Lay sod within 48 hours of harvesting unless a suitable preservation method is accepted by Architect prior to delivery time. Do not lay sod if dormant or if ground is frozen or muddy.

Lay sod to form a solid mass with tightly fitted joints. Butt ends and sides of sod; do not stretch or overlap. Stagger sod strips or pads to offset joints in adjacent courses. Avoid damage to soil or sod during installation. Tamp and roll lightly to ensure contact with soil, eliminate air pockets, and form a smooth surface. Work sifted soil or fine sand into minor cracks between pieces of sod; remove excess to avoid smothering sod and adjacent grass.

Saturate sod with fine water spray within two hours of planting. During first week after planting, water daily or more frequently as necessary to maintain moist soil to a minimum depth of 1" below sod.

Trim sod to conform to shapes on Planting Plans.

Irrigate thoroughly to provide good moisture penetration after sod is laid.

Sod shall be smooth and flush with the finish grade of existing sidewalks, curbs, etc. A second rolling will be necessary if the first does not meet with these specifications.

801-4.9.5 Watering [Add the following]

It will be the Contractor's responsibility to maintain a balanced watering program to ensure all grass areas receive proper amounts of water, well below the root system of plants. It is the contractor's responsibility to water (by hand if needed) all sod. Any sod that dies as a result of the contractor's neglect shall be replaced by the contractor at no cost to the District. This includes any equipment needed, labor and materials.

801-5 IRRIGATION SYSTEM INSTALLATION.

801-5.1 General. [Add the following]

The drawings are essentially diagrammatic. Minor adjustments may be required due to differences between the site and drawings.

Dig trenches and support pipe continuously on bottom of the ditch. Lay pipe to a level grade. Trenching excavation will follow layouts indicated on the drawings to the depth below finish grades as noted. Provide minimum cover of 24 inches for main pressure supply lines under pavement, 18 inches of cover if not under pavement, and 12 inches cover for all lateral lines.

Provide minimum cover of 18 inches, maximum 24 inches for control wires. Excavation in areas where there are tree roots 2-inches in diameter and larger will be tunneled under and will be heavily wrapped with wet burlap to prevent scarring or dying.

New wiring will occupy the same trench and will be installed along the same route as the pressure supply lines and will be located below the supply lines wherever possible. Where more than one wire is placed in a trench, the wiring will be taped together at intervals of 12 feet and labeled with numbers at each end of the wire.

Remote control wire will be direct-burial AWG-UF type, sized according to manufacturer specifications, and in no case smaller than 14-gauge. Connections shall be either epoxy-sealed packet-type or Penn-Tite connectors. Common wires for valves shall be white in color. Control wires shall be black and numbered. An extra numbered wire shall be installed from controller to each valve location and it shall be different (not white) in color.

An extra valve control wire will be installed for every control valve manifold. Each extra control wire will be of a different color, extended to last valve, and be looped into each valve box.

801-5.3 Irrigation Pipeline Installation.

801-5.3.3 Plastic Pipeline. [Add the following]

All threaded plastic-to-plastic connections will have Teflon tape applied to the male threads of connection prior to assembly. The number of wraps of Teflon tape shall be per manufacturer's recommendations or per industry standards.

Connect all metal components to plastic pipe connections with a schedule 80 nipple, threaded one end, and a plastic slip coupling. Use Teflon tape on all male threads prior to assembly.

801-5.3.5 Sleeving [Add subsection]

PVC Conduit Sleeves for irrigation piping and electrical conduit and conductors shall conform to the provisions in Section 800-2, "Irrigation System Materials," of the Standard Specifications and these Special Provisions.

Sleeves shall include two conduits for water line, electrical and sprinkler control crossovers. Sizes of the conduits shall be as shown on the plans or as specified in the special provisions.

The estimated quantity of conduit listed on the plan represents the total length of a unit run times two conduits. The length of each individual run is noted on the construction plan sheets.

Conduits shall be installed not less than 1.5 feet below the top of curb grade in sidewalk areas and not less than 24 inches below finished grade in all other areas measured to the top of the conduit. Conduits shall extend 5 feet beyond all paving and curbs unless otherwise shown on the plans.

Where conduits are installed in open trenches, excavation and backfill shall conform to the provisions in Section 306, "Open Trench Conduit Construction," of the Standard Specifications and these specifications. The bottom of the trench shall be graded and prepared to provide a firm and uniform bearing throughout the entire length of the conduit. During backfilling operations, the conduit shall be rigidly supported so that no movement of, or damage to, the conduit or joints will result.

Couplings for conduits shall be installed in conformance with the manufacturer's written instructions; a copy of which shall be furnished to the Inspector prior to installation

Conduits shall be schedule 40 PVC pipe. Couplings and fittings shall be as recommended by the pipe manufacturer. Nylon pull rope shall be placed in conduit for the full length of the conduit.

Each end of the irrigation sleeve shall be terminated, capped and a 1" by 24" iron pipe shall be embedded at the pipe end for future locating as noted in the plans.

If new sleeving is required, install per plan.

801-5.5 Sprinkler Head Installation and Adjustment.

801-5.5.2 Location, Elevation, and Spacing [Add the following]

Sprinkler heads will be installed as designated on the drawings. Spacing of the sprinkler heads will not exceed maximum indicated on the drawings.

801-5.6 Automatic Control System Installation [Add the following]

801-5.7 Flushing and Testing.

801-5.7.1 General. [Add the following]

Irrigation design is based on available water pressure as indicated by CVWD. The Contractor will verify working water pressure prior to construction. Should a discrepancy exist, notify the District prior to beginning Construction.

Connections to the installation of the water supply will be at the location shown on the drawings. Minor changes caused by actual site conditions will be made at no additional cost to the District. If the water meter and backflow unit is existing refer to Irrigation plans. Contractor shall run mainline pipe to the as indicated on the plans.

Prior to installation of irrigation heads, the valves will be opened and full head of water used to flush out the lines and risers. Sprinkler heads shall not be installed until flushing the system has been completed.

801-5.7.2 Pipeline Pressure Test. [Add the following]

The main line will be tested for no less than four (4) hours and hold a static pressure of 125 psi.

801-6 Maintenance and Plant Establishment.

801-6.1 General. [Add subsection]

The Contractor shall maintain all landscaped areas for a minimum plant establishment period of not less than ninety (90) days from the date of written acceptance of the project. The plant establishment period will not start until the project receives Final, Formal Acceptance by the District Council. Projects will not be segmented into phases or accepted in phases. Written acceptance from the District must be obtained to start the plant establishment period. If the project maintenance fails to continuously meet standards required, the plant establishment period will be suspended and will not re-commence until Contractor has corrected all deficiencies.

801-6.2 Maintenance Tasks. [Add subsection]

During the contract period the Contractor shall maintain the planted areas which are within the work limits of the contract including, but not limited to weekly: 1) watering; weekly mowing; weeding; fertilizing and cultivating; and spraying to keep the sod in a healthy, growing condition and keeping the planted areas neat and attractive; 2) removing trash a minimum of once a week; 3) checking and repairing irrigation systems weekly; and 4) pest and vermin control. Note: Do not prune trees or shrubs without first advising the District.

801-6.3 Replacement Plantings. [Add subsection]

After planting and during the plant establishment period in the event any sod should die, is missing, weak or displays the appearance of necrosis, the sod will be immediately removed and replaced at the Contractor's expense. All replacements must occur within five (5) days of notice. At the end of the establishment period, all sod will be in a healthy, growing condition and located as indicated on the plan or as approved by the District.

801-6.5 Weekly Reports. [Add subsection]

The Contractor, as part of this contract, shall submit reports and schedules as requested. Failure to submit reports and schedules in the time specified may result in a Performance Deficiency Deduction. The District will supply the format for these forms. Such reports must be filled out in detail.

The following is a breakdown of required forms and schedules.

The contractor shall submit these reports as they are completed. Weekly reports shall be filled out by Friday of every week. Payments due shall not be disbursed unless all reports have been submitted to the District.

801-6.5.1 Schedule of Weekly Maintenance. [Add subsection]

- a) Contractor shall provide a schedule of weekly maintenance identifying areas to be maintained and a breakdown of when each function shall be performed.
- b) The District will assume that the Contractor will adhere to the schedule. The District must receive notification of changes at least 12 hours in advance.

801-6.5.2 Weekly Irrigation Inspection Report. [Add subsection]

This will be turned in every Friday.

801-6.5.3 Weekly Activity Report. [Add subsection]

Indicating the following:

- a) Litter pickup
- b) Weed control
- c) Chemical maintenance - herbicides and pesticide applications
- d) Incident/Accident

801-6.7 End of Establishment Period. [Add subsection]

Approximately one week prior to the end of the establishment period, the District will conduct a walk-through of the area, noting deficiencies and problems to be resolved. The Contractor will be required to resolve all noted items. If the items cannot be resolved within the time remaining, the establishment period will be extended, without cost to the District, until the items are corrected.

PAYMENT

The contract paid price for **Landscape** shall be measured and paid for per **Lump Sum (LS)** and shall include furnishing all labor, equipment, tools, transportation, and materials necessary for placement of landscaping per approved plans. The price of this item shall also include protecting electrical in place, exporting soil, grading, providing and installing sod and any incidentals for doing the work involved in constructing landscaping per District Standards and project plans and specifications.

The contract paid price for **Irrigation** shall be measured and paid for per **Lump Sum (LS)** and shall include furnishing all labor, equipment, tools and materials necessary for construction of irrigation per approved plans. The price of this item shall also include protecting electrical in place, exporting soil, grading, providing and installing irrigation system, irrigation controller, permits, coordination with CVWD, and any incidentals for doing the work involved in constructing irrigation per the project plans and specifications.

The contract paid price for **90-Day Maintenance Period** shall be measured and paid for per **Lump Sum (LS)** and shall include furnishing all labor, equipment, tools and materials necessary for maintenance of constructed landscaping per approved plans. The price of this item shall also include any incidentals for doing the work involved in maintaining and establishing constructed landscaping as defined in the project plans and specifications.

5.0 CLEAN UP

Throughout all phases of construction, including suspension of work and until the final acceptance, the Contractor shall keep the site clean and free from rubbish and debris.

The Contractor shall remove and dispose of all loose material and debris caused by construction operations from the construction site on a daily basis.

Materials and equipment shall be removed from the site as soon as they are no longer necessary. Before the final inspection, the site shall be cleared of equipment, unused materials, and rubbish so as to present a satisfactory clean and neat appearance. All cleanup costs shall be included in the Contractor's Bid.

Care shall be taken to prevent spillage on haul routes. Any such spillage shall be removed immediately and the area cleaned.

Failure of the Contractor to comply with the District's clean up orders may result in an order to suspend work until the condition is corrected. No additional compensation will be allowed as a result of such suspension.

Before final inspection of the work, the Contractor shall clean the right-of-way, private property, material sites, and all ground occupied by the Contractor in connection with the work of all rubbish, excess materials, falsework, temporary structures, and equipment. All parts of the work shall be left in a neat and presentable condition.

The full compensation for collecting and disposing of loose material and debris from the job site shall be considered as included in the contract prices paid for the various items of work involved and no additional compensation will be allowed therefore.

***** END OF SECTION *****

EXHIBIT B

SOIL TESTING REPORT

**IMPERIAL COUNTY
DESERT SHORES SOCCER PARK
PHASE 1
57 PALM DRIVE, DESERT SHORES, CA 92274**

COUNTY PROJECT NO. SR53009



Anaheim Office
Lab No: 23-109-0019
April 26, 2023

Hermann Design Group, Inc.
77-899 Wold Rd. STE.# 102
Palm Desert, CA 92211

Attn: Jose Estrada

Project: Desert Shores Park

Attached are the results of the analysis performed on a soil sample that was collected from the above mentioned project site from a depth of 12 inches by the client and received by our laboratory on April 19, 2023. Organic fertilizer and amendment recommendations were requested. This sample was analyzed for nutrient levels, agricultural suitability, and physical characteristics in preparation for new landscape installation.

Analytical Results and Comments

The reaction of the soil is slightly alkaline at 7.5 on the pH scale with a high level of free lime present. These levels could cause plants that are sensitive to alkalinity to show yellowing of foliage beginning with the younger growth. A high level of free lime is present indicating that the pH is strongly buffered in the alkaline range. Incorporation of soil sulfur to a depth of 6 inches may adjust the pH downward toward the preferred near neutral range to the depth of incorporation. That change would happen slowly and plants that are sensitive to alkalinity should be avoided.

Salinity (ECe) is high at 16.2 dS/m and is largely due to an abundance of soluble sodium (188 meq/L). These salt levels far exceed the tolerance threshold of most ornamental plant material. Very salt tolerant turf species such as seashore paspalum could potentially tolerate these salt levels if well established and the grass is not stressed by other factors such as heavy traffic, compaction, over watering, under watering, soil compaction, pest infestation, disease, or low light conditions. If the grass is stressed by other factors, then even salt tolerant species could become less tolerant of elevated salts. The salt levels will restrict the use of all but salt tolerant ornamental trees and shrubs as well. The sodium present is very poorly balanced by other cations as indicated by the high sodium adsorption ratio (SAR) of 39. This sodium imbalance is expected to adversely affect soil structure and water infiltration.

Boron is elevated at 3.23 parts per million (ppm), which could cause a broad range of trees and shrubs to show tip and edge burning of older leaves and plants that are not tolerant of elevated levels of boron in the soil are expected to perform poorly. Common turfgrass species should tolerate this amount of boron in the soil.

In terms of fertility, phosphorus is very low and magnesium is moderately low. In the minor element category, copper, manganese, and iron are low while zinc is moderately low.

The texture of the sample is 'sandy loam' based on the USDA soil classification standards. The estimated water infiltration rate is a moderate 0.28 inch per hour. The infiltration rates may vary with the degree of soil compaction throughout the site. Organic content is low at 0.81% on a dry weight basis.

4741 East Hunter Ave., Ste. A Anaheim CA 92807
(714) 282-8777  (714) 282-8575 fax
www.waypointanalytical.com



Page 2
Hermann Design Group, Inc.
April 26, 2023

Comments and Recommendations

Reclamation is required prior to planting in order to reduce the soluble salts in the root zone to a safer range. Leaching should also reduce the boron to a degree but removal of boron by leaching is about three times as difficult as for other salts. We recommend the first several irrigations should be especially thorough to try to accomplish some leaching prior to planting. Proper plant selection will be an important factor in establishing a successful landscape. Use plants tolerant of these conditions. If drainage is impeded by compaction or other underlying factor, the areas may require deep ripping in order to improve drainage and allow for the leaching of salts past the root zone. The organic amendment, sulfur, and bone meal should be incorporated prior to leaching.

We estimate that approximately 7 inches of good quality water low in soluble salts and boron needs to move through the soil in order to reduce the salinity to a safe level of 3.5 dS/m in the surface 12 inches of soil. Keep in mind that as salts and boron are flushed out of the root zone, salinity and boron in the subsoil will likely remain elevated.

Be sure to apply leaching irrigations in a manner that avoids run-off and pooling. The soil should be allowed to dry slightly between irrigations to avoid creating anaerobic soil conditions and/or an environment that favors root diseases. As mentioned above, drainage must be sufficient for leaching to be effective.

Gypsum (calcium sulfate) application is often recommended for downward SAR adjustment. However, in this case the soluble calcium and sulfate numbers are high, indicating an abundance of gypsum already in the soil. Due to the limited solubility of gypsum, it is not likely that an addition of that material would provide much benefit at this point. It is also worth noting that when a sodium imbalance issue is accompanied by a very high salinity value, as in this case, water infiltration is often good in spite of the elevated SAR. As leaching irrigations flush calcium and magnesium out of the root zone, along with sodium, water infiltration may become impeded. If this happens, gypsum application may be warranted at that time and the material should be uniformly broadcast at a rate of 25 lbs. per 1000 sq. ft. followed by additional leaching.

Once leaching is complete, it is recommended to submit additional samples to check post-leaching salinity and SAR values (Waypoint Analytical Testing Procedure A02). Additional leaching and/or gypsum application may be necessary at that time.

4741 East Hunter Ave., Ste. A Anaheim CA 92807
(714) 282-8777  (714) 282-8575 fax
www.waypointanalytical.com



Page 3
Hermann Design Group, Inc.
April 26, 2023

Recommendations

Surface Soil Preparation for Turf and Mass Planting Areas

If feasible, prior to amending the areas where severe compaction exists, the surface soil should be ripped or tilled to a 9-inch depth. Uniformly broadcast and blend the following with existing soil to a 6-inch depth. 12-0-0 fertilizer should be raked or scratched into the surface 3-4 inches after leaching. Since soil salinity is high, a non-saline organic amendment should be selected.

<u>Materials</u>	<u>Amount per 1000 sq. ft.</u>
Nitrogen fortified organic amendment (compost* or redwood or fir sawdust)	3 cu. yards
Soil Sulfur	12 lbs.
Feather Meal (12-0-0)	10 lbs.
Bone Meal (3-15-0)	25 lbs.

*Rates and fertilizers may have to be adjusted depending on analysis of selected compost.

Tree and Shrub Planting Guidelines for General Ornamentals

1. Excavate planting pits at least twice the diameter of the rootball.
2. The top of the rootball should be at or slightly above final grade.
3. To improve soil chemistry, uniformly blend 1 lb. of iron sulfate per cubic yard of backfill soil. Handle iron sulfate with caution since it will severely stain moist concrete. Iron sulfate is not organic but it is often acceptable for use if warranted.
4. To improve soil fertility, uniformly blend 1.3 lbs. of bone meal (3-15-0) and 0.5 lb. of feather meal (12-0-0) per cubic yard of backfill. Limit the fertilizers to the upper 12 inches of backfill only.
5. Organic material is not required in the backfill; however, if you wish, the amended surface soil or a soil blend consisting of no more than 20% by volume organic matter can be placed in the upper 12 inches of backfill only. Soil below this depth should not contain any added organic matter because of the threat of plant disease and/or anaerobic soil conditions developing.
6. Do not cover the original rootball with other soil. Ideally, a temporary soil berm is often constructed around the outer edge of the rootball to help channel water into the rootball and then into surrounding soil until roots are established in the backfill and the rootball is no longer the sole source of water for the plant.
7. Ideally, a weed and turf free zone, preferably 2-3 ft. in diameter, should be maintained just beyond the diameter of the planting hole. A 2-4 inch deep layer of coarse mulch can be placed around the tree or shrub; mulch should be kept a minimum 4-6 inches from the trunk.

4741 East Hunter Ave., Ste. A Anaheim CA 92807
(714) 282-8777 (714) 282-8575 fax
www.waypointanalytical.com



Page 4
Hermann Design Group, Inc.
April 26, 2023

Maintenance fertilization may rely primarily on a nitrogen only program supplemented with a complete fertilizer in the fall and spring. Blood Meal (12-0-0) provides available nitrogen fairly rapidly while materials such as Feather Meal (12-0-0), Soybean or Cotton Seed Meal (7-1-1) are slower to provide available nitrogen, but they extend the length of time they make this contribution. In order to provide a good supply of nitrogen for a 3-4 month time frame a good combination would be 6 pounds Blood Meal and 14 pounds Feather Meal per 1000 sq. ft. The first application should be approximately 60-90 days after planting or at the first mowing in turf areas. The long term maintenance program should consider spring and fall applications of an organic fertilizer blend such as Nature Safe 8-5-5 that would also supplement phosphorus and potassium nutrition to a greater extent.

As noted above, some of the micronutrients are below optimum. When these nutrients are low, especially in an alkaline soil, deficiencies can sometimes show in the plants. If deficiencies show once plants have become established, they may be addressed upon the first sign of deficiency. Symptoms of manganese deficiency may be seen as a general loss of color in the young leaves, followed by yellowing between veins and brownish-black spots appearing. Iron and zinc deficiency symptoms are often characterized by yellow, almost white, interveinal chlorosis on the youngest growth. If these symptoms are apparent once plants are established, then application of iron, zinc, and/or manganese chelate at the manufacturer's label rate may improve appearance. Many of the chelated micronutrient products on the market are not organic materials but are often more effective on alkaline soils than some of the other forms of trace elements. Chelated micronutrients are generally accepted fertilizers in organic production as long as there is a need for zinc, manganese, and iron demonstrated by testing. Decreasing the soil pH to a more favorable range would also help improve micronutrient availability.

If we can be of any further assistance, please feel free to contact us.

A handwritten signature in blue ink, appearing to read "Joe Kiefer".

Joe Kiefer, CCA

4741 East Hunter Ave., Ste. A Anaheim CA 92807
(714) 282-8777 (714) 282-8575 fax
www.waypointanalytical.com

Page 4 of 5

Hermann Design Group, Inc.
77-899 Wolf Rd. Suite 102
Palm Desert CA 92211



4741 East Hunter Ave. Suite A
Anaheim, CA 92807
Main / 714-282-8111 • Fax / 714-282-8571
www.waypointanalytical.com

Project : Desert Shores Park

Report No : 23-109-0019

Purchase Order :

Date Recd : 04/19/2023

Date Printed : 04/25/2023

Page : 1 of 1

COMPREHENSIVE SOIL ANALYSIS

Sample Description - Sample ID		Half Sat %	pH	ECe dS/m	NO ₃ -N ppm	NH ₄ -N ppm	PO ₄ -P ppm	K ppm	Cu ppm	Mg ppm	Cu ppm	Zn ppm	Mn ppm	Fe ppm	Organic % dry wt	Lab No.	
		TEC	Qual Limit														
SR8 Soil		17	7.5	88.3	58	6	2	218	1280	122	0.4	2.8	1	2	0.81	42882	
		99	High		1.1		0.1	1.5	0.8	0.8	0.3	0.5	0.1	0			
Sufficiency Factors																	
Percent of Sample Passing 2 mm Screen																	
Saturation Extract Values		Gravel %		Sand		Very Coarse		Coarse		Med. to Very Fine		Silt		Clay		USDA Soil Classification	Lab No.
Ca mg/L	Mg mg/L	Na mg/L	K mg/L	B ppm	SO ₄ mg/L	SAR	5-12	1-2	0.5-1	0.05-0.6	0.02-0.05	0-0.02	USDA Soil Classification	Lab No.			
32	12.8	143	3.2	3.29	57	39.7	0.2	2.7	24.5	21.8	31.5	11.4	10.4	Sandy Loam	42882		

Sufficiency factor (1.0-suffices for average crop) below each nutrient value. N factor based on 200 ppm extractable N. SAR - Sodium adsorption ratio. Field Saturation % - approx field moisture capacity. Nitrogen(N), Phosphorus(P), Potassium(K), Calcium(Ca) and Magnesium(Mg) by sodium chloride extraction. Phosphorus(P) by sodium bicarbonate extraction. Copper(Cu), Zinc(Zn), Manganese(Mn) & Iron(Fe) by DTPA extraction. Sat. ext. method for sulfate (ECe as dS/m) based on (B), Sulfate(SO₄), Sodium(Na). Gravel fraction expressed as percent by weight of oven-dried sample passing a 12mm (1/2 inch) sieve. Particle sizes in millimeters. Organic percentage determined by Walkley-Black or Loss on Ignition.

LOW . SUFFICIENT . HIGH

EXHIBIT C

SITE PLAN

**IMPERIAL COUNTY
DESERT SHORES SOCCER PARK
PHASE 1**

COUNTY PROJECT NO. SR53009

LANDSCAPE CONSTRUCTION PLANS

DESERT SHORES SOCCER PARK

PREPARED FOR: SALTON COMMUNITY SERVICES DISTRICT
 1209 VAN BUREN AVENUE
 SALTON CITY, CA 92274
 OFFICE (760) 394-4446
 CONTACT: EMMANUEL RAMOS

PROJECT TYPE: COMMUNITY PARK
 PORTION OF SECTION 16, T.9S, R.9E, SBB#M

CONSULTANTS



HERMANN DESIGN GROUP
 77-899 WOLF RD.
 SUITE 102
 PALM DESERT, CA
 92211

LIC# 2754 EXP. 04/30/24
 PH. (760) 777-9131
 FAX (760) 777-9132

OWNER:
SALTON COMMUNITY SERVICES DISTRICT
 1209 VAN BUREN AVENUE
 THERMAL, CA 92274
 OFFICE (760) 394-4446

GENERAL NOTES

1. ALL WORK SHALL BE IN ACCORDANCE WITH APPLICABLE CITY AND COUNTY CODES AND THESE PLANS.
- A. THE CONTRACTOR SHALL CARRY ALL WORKERS COMPENSATION, PUBLIC LIABILITY AND PROPERTY DAMAGE INSURANCE AS REQUIRED BY OWNER.
- B. THE CONTRACTOR SHALL APPLY FOR ALL PERMITS AND PAY FOR SAME.
- C. ALL IRRIGATION WORK SHALL HAVE RECOMMENDED APPROVAL BY THE OWNER PRIOR TO BEGINNING ANY GROUND COVER PLANTING WORK.
- D. THE OWNER'S REPRESENTATIVE WILL REVIEW THE PLANTING WORK. PRIOR TO STARTING WORK THE CONTRACTOR SHALL CONTACT THE OWNER'S REPRESENTATIVE AND COORDINATE ALL REVIEWS.
- E. THE QUALITY OF WORKMANSHIP AND MATERIALS SHALL BE OF THE HIGHEST STANDARDS. COOPERATION AND FLEXIBILITY IS EXPECTED OF THE CONTRACTOR TOWARD WORKING WITH THE OWNER / LANDSCAPE ARCHITECT IN PRODUCING THE BEST POSSIBLE PRODUCT.
2. BY EXECUTING THE CONTRACT, THE CONTRACTOR REPRESENTS THAT HE AND HIS SUBCONTRACTORS HAVE VISITED THE SITE, FAMILIARIZED THEMSELVES WITH ALL CONDITIONS UNDER WHICH THE WORK IS TO BE PERFORMED, AND CORRELATED THEIR OBSERVATIONS WITH THE REQUIREMENTS OF THESE CONTRACT DOCUMENTS.
3. UNLESS OTHERWISE PROVIDED IN THESE CONTRACT DOCUMENTS, THE CONTRACTOR SHALL SECURE AND PAY FOR ALL PERMITS, FEES, LICENSES, AND INSPECTIONS NECESSARY FOR THE PROPER EXECUTION AND COMPLETION OF THE WORK.
4. THE CONTRACTOR SHALL FILE ALL NOTICES AND COMPLY WITH ALL LAWS, ORDINANCES, RULES, REGULATIONS, AND LAWFUL ORDERS OF ANY PUBLIC AUTHORITY BEARING ON THE PERFORMANCE OF THE WORK. IF THE CONTRACTOR OBSERVES THAT ANY OF THE CONTRACT DOCUMENTS ARE AT VARIANCE THEREWITH IN ANY RESPECT, HE SHALL PROMPTLY NOTIFY THE OWNER'S AUTHORIZED REPRESENTATIVE IN WRITING.
5. CONTRACTOR SHALL OBTAIN A CURRENT STRUCTURAL SOILS REPORT. THIS SOILS REPORT SHALL SUPERSEDE THE RECOMMENDATIONS AND DETAILS SHOWN ON THESE PLANS AND SPECIFICATIONS.
6. CONTRACTOR SHALL VERIFY LOCATION OF ALL UTILITIES PRIOR TO CONSTRUCTION AND SHALL BE HELD LIABLE FOR ALL DAMAGE INCURRED DURING CONSTRUCTION.
7. CONTRACTOR SHALL VERIFY ALL DIMENSIONS AND CONDITIONS PRIOR TO THE START OF CONSTRUCTION. CONTRACTOR SHALL NOTIFY THE OWNER'S REPRESENTATIVE OF ANY DISCREPANCIES.
8. CONTRACTOR SHALL NOT WILLFULLY PROCEED WITH CONSTRUCTION WHEN IT IS OBVIOUS THAT UNKNOWN OBSTRUCTIONS AND/OR GRADE DIFFERENCES EXIST THAT MAY NOT HAVE BEEN KNOWN DURING DESIGN. SUCH CONDITIONS SHALL BE IMMEDIATELY BROUGHT TO THE ATTENTION OF THE OWNER'S AUTHORIZED REPRESENTATIVE. THE CONTRACTOR SHALL ASSUME FULL RESPONSIBILITY FOR ALL NECESSARY REVISIONS DUE TO FAILURE TO GIVE SUCH NOTIFICATIONS.
9. THE LOCATION OF FEATURES TO BE CONSTRUCTED, NOT SPECIFICALLY DIMENSIONED MAY BE DETERMINED BY SCALE. VERIFY ALL SUCH CONDITIONS WITH OWNER'S REPRESENTATIVE.
10. ALL CURVE-TO-LINEAR AND CURVE-TO-TANGENT LINES SHALL BE NEAT, TRIM, SMOOTH, AND UNIFORM.
11. THE CONTRACTOR SHALL AT ALL TIMES KEEP THE PREMISES FREE FROM ACCUMULATION OF WASTE MATERIALS OR RUBBISH CAUSED BY HIS OPERATIONS. AT THE COMPLETION OF THE WORK HE SHALL REMOVE ALL HIS WASTE MATERIALS AND RUBBISH FROM THE SITE AS WELL AS ALL HIS TOOLS, EQUIPMENT, MACHINERY, AND SURPLUS MATERIALS.
12. THE CONTRACTOR SHALL BE RESPONSIBLE FOR INITIATING, MAINTAINING, AND SUPERVISING ALL SAFETY PRECAUTIONS AND PROGRAMS IN CONNECTION WITH THE WORK.
13. THE CONTRACTOR SHALL PROMPTLY CORRECT ALL WORK REJECTED BY THE OWNER'S AUTHORIZED REPRESENTATIVE AS DEFECTIVE OR AS FAILING TO CONFORM TO THE CONTRACT DOCUMENTS. THE CONTRACTOR SHALL BEAR ALL COSTS OF CORRECTING SUCH REJECTED WORK.
14. PRIOR TO THE START OF CONSTRUCTION, THE CONTRACTOR SHALL VERIFY WITH THE OWNER'S AUTHORIZED REPRESENTATIVE THAT HE/SHE HAS OBTAINED THE LATEST SET OF CONSTRUCTION DOCUMENTS.
15. ALL PHOENIX AND CITRUS SPECIES SHALL BE PURCHASED IN THE COACHELLA VALLEY FROM A LOCAL NURSERY AS PER AGRICULTURAL COMMISSIONER GUIDELINES.

VICINITY MAP

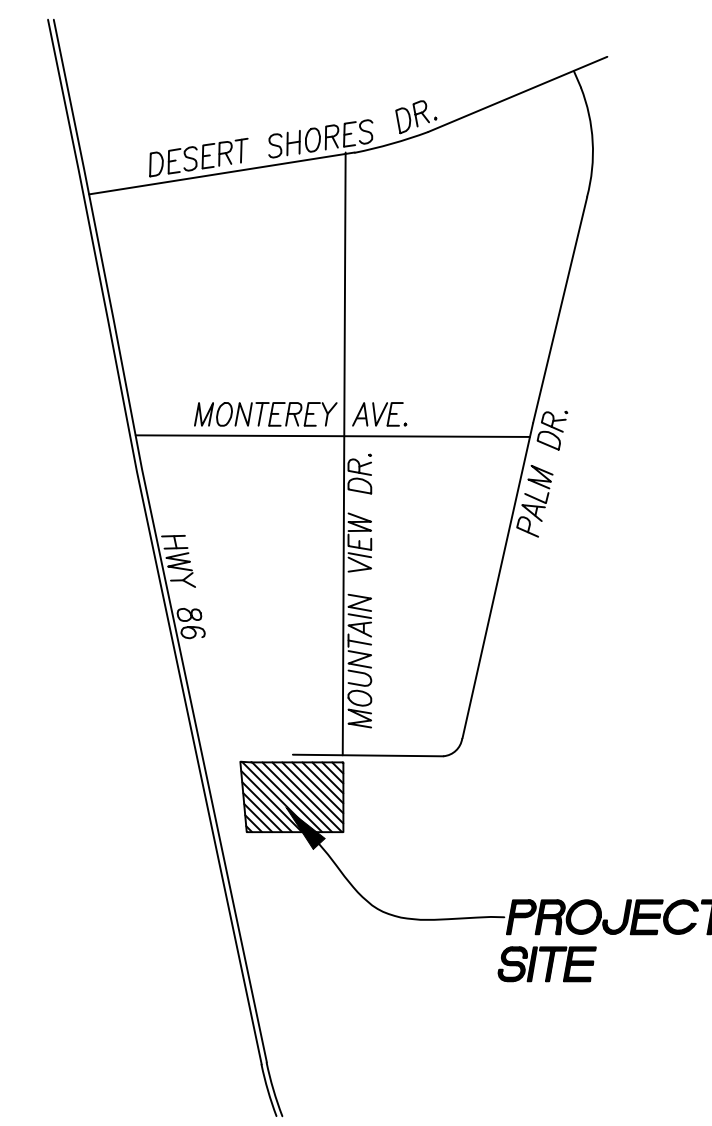

N.T.S.

SHEET INDEX

SHEET	DESCRIPTION
L0.0	COVER SHEET
L1.0	IRRIGATION PLAN
L1.1	IRRIGATION PLAN
L1.2	IRRIGATION DETAILS
L1.3	IRRIGATION DETAILS
L2.0	PLANTING PLAN
L2.1	PLANTING PLAN
L2.2	PLANTING DETAILS
L2.3	SOILS REPORT

APPROVALS

NO PERMANENT STRUCTURES OR TREES WITHIN CVOID AND/OR EASEMENTS. CVOID WILL NOT BE RESPONSIBLE FOR DAMAGE OR REPLACEMENT OF ANY TREES, PLANTS, WALLS AND PERMANENT STRUCTURE OF ANY KIND MAY SURFACE IMPROVEMENTS, INCLUDING BUT NOT LIMITED TO, DECORATIVE CONCRETE, LANDSCAPING, CURB, GUTTER, SIDEWALKS, PLANTERS, GATES AND RELATED IMPROVEMENTS INSTALLED WITHIN THE CVOID AND/OR USBR.

THESE PLANS HAVE BEEN REVIEWED BY THE COACHELLA VALLEY WATER DISTRICT IN ACCORDANCE WITH CALIFORNIA GOVERNMENT CODE, SECTION 65951 ET SEQ. REQUIRING EFFICIENT LANDSCAPE AND IRRIGATION DESIGN IN COOPERATION WITH THE LOCAL GOVERNING AGENCY (CITY AND COUNTY).

APPROVAL OF THIS DRAWING BY CVOID STAFF DOES NOT CONSTITUTE APPROVAL TO ENCRoACH INTO DISTRICT AND USBR RIGHT OF WAY. TREES, PLANTS, WALLS AND PERMANENT STRUCTURE OF ANY KIND MAY NOT BE PLANTED OR INSTALLED IN CVOID AND USBR EASEMENTS OR RIGHT-OF-WAY WITHOUT FIRST OBTAINING AN ENCROACHMENT PERMIT FROM CVOID.

DATE _____ WATER MANAGEMENT DEPARTMENT _____
 CVOID PLAN NO. _____ DEVELOPMENT SERVICES DEPARTMENT _____

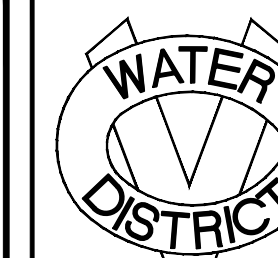
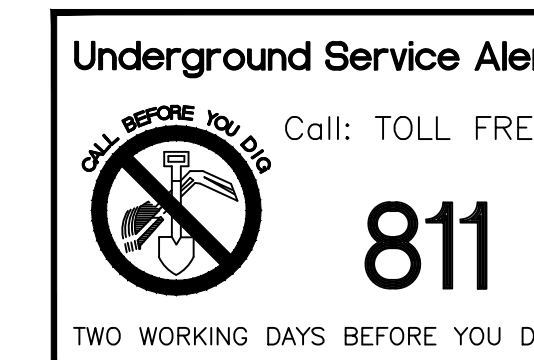

PROJECT:
DESERT SHORES SOCCER PARK
 001-155-001
 THERMAL CA, 92274

REVISIONS	DATE	BY



SHEET TITLE
COVER SHEET

DESIGNED	JE
DRAWN	JE
CHECKED	CH
DATE	6/20/23
SCALE	N.T.S.
JOB NO.	23013

SHEET
L0.0
 OF 9 SHEETS

© Hermann Design Group. All rights reserved. No part of this document may be reproduced, stored in a retrieval system, or transmitted in any form or by any means, electronic, mechanical, photocopying, recording, or by any information storage and retrieval system, without the prior written permission of Hermann Design Group.



HERMANN DESIGN GROUP
 77-899 WOLF RD.
 SUITE 102
 PALM DESERT, CA
 92211
 LIC# 2754 EXP. 04/30/24
 PH. (760) 777-9131
 FAX (760) 777-9132

OWNER:
SALTON COMMUNITY SERVICES DISTRICT
 1209 VAN BUREN AVENUE
 THERMAL, CA 92274
 OFFICE (760) 394-4446

PROJECT:
DESERT SHORES SOCCER PARK
 001-155-001
 THERMAL CA, 92274

REVISIONS	DATE	BY



SHEET TITLE
IRRIGATION PLAN

DESIGNED **JE**
 DRAWN **JE**
 CHECKED **CH**
 DATE **6/20/23**
 SCALE **1"=20'**
 JOB NO. **23013**

SHEET
L1.0
 OF 9 SHEETS

AUTOMATIC CONTROLLER LOCATION: A
 INSTALL AUTOMATIC CONTROLLER- 24 STATION
 LOCATE IN VANDAL RESISTANT ENCLOSURE
 MODEL: SB-24SS BY STRONGBOX
 CONTRACTOR TO MAKE FINAL HOOK UP.

MATCH LINE SEE SHEET L1.1

PHASE 2 ALTERNATE BID

PHASE 1

INSTALL 1" REMOTE CONTROL VALVE AND EXTEND LATERAL FOR FUTURE TREE IRRIGATION - BASE BID

TREES BY OWNER

EXISTING BASKETBALL COURT

TREES BY OWNER

EXISTING LIGHTS

EXISTING BACK STOP

EXISTING CHAIN LINK FENCE

INSTALL 1" REMOTE CONTROL VALVE AND EXTEND LATERAL FOR FUTURE TREE IRRIGATION - BASE BID

SYMBOL	MANUFACTURER/MODEL #	SIZE	DETAIL / SHEET
	EXISTING IRRIGATION WATER METER. PROTECT IN PLACE	-	-
	NIBCO T-500 BALL VALVE - FULL PORT	LINE SIZE	C / L1.2
	RAINBIRD FEB SERIES REMOTE CONTROL VALVE	PER PLAN	H / L1.2
	RAINBIRD ESP-LXME/F AUTOMATIC IRRIGATION CONTROLLER WITH IQ NCC SS CARTRIDGE AND COMMUNICATION ANTENNA / INSTALL IN STRONGBOX ENCLOSURE MODEL: SB-24SS INSTALL PER MANUFACTURER'S SPEC.	36	E / L1.2
	EXISTING BACKFLOW PREVENTER. PROTECT IN PLACE	-	-
	RAINBIRD FS150P FLOW SENSOR	1 1/2"	J / L1.3
	GRISWOLD 2000 SERIES MASTER VALVE	2"	I / L1.3
	RAINBIRD 44-RC QUICK COUPLING VALVE	1"	F / L1.2
NOT SHOWN	UF DIRECT BURIAL CONTROL WIRE #12 GA. COMMON, #14 GA. PILOT W/ PIPE SLEEVE	-	B / L1.2
	PVC SCH 40 FOR 1 1/2" AND SMALLER, PVC CLASS 915 FOR 2"-3". PRESSURE MAINLINE -10" DEEP. PVC C900 FOR 4" AND LARGER. PRESSURE MAINLINE -36" DEEP	PER PLAN	B / L1.2
	SCH 40 PVC NON-PRESSURE LATERAL LINE. 12" DEEP.	PER PLAN	B / L1.2
	SCH 40 PVC WIRE AND PIPE SLEEVES	2x LINE SIZE	A / L1.2

SYMBOL	MANUFACTURER/MODEL #	NOZZLE	RAD.	PSI	FLOW (GPM)				DETAIL / SHEET
					Q	H	F	VAN	
	RAINBIRD 1806-SAM-FRS-10	Q/H/F/V	10'	30	39	1.9	1.58	1.18	D / L1.2
	RAINBIRD 1806-SAM-FRS-12	Q/H/F/V	12'	30	65	1.30	2.6	.87	
	RAINBIRD 1806-SAM-FRS-15	Q/H/F/V	15'	30	92	1.85	3.7	2.77	
	HUNTER 1-20-06-SS NOZZLES: 3.0 BLUE QTR. NOZZLES: 4.0 BLUE HALF	Q/H	35'	35	2.7	3.5			
	HUNTER 1-20-06-SS NOZZLES: 8.0 BLUE FULL	F	35'	35			7		

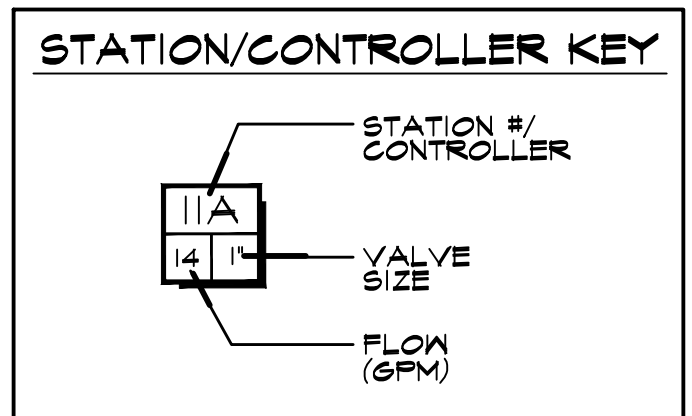

SCHEDULE 40 PVC PIPE SIZING CHART

1 - 7	GPM	3/4"
8 - 12	GPM	1"
13 - 21	GPM	1 1/2"
22 - 29	GPM	1 3/4"
30 - 49	GPM	2"
50 - 69	GPM	2 1/2"
70 - 109	GPM	3"

BID ALTERNATE SCHEDULE

BID ITEM	SYMBOL	DESCRIPTION	COMMENTS
1		PHASE 2 IRRIGATION 25,557 S.F.	INSTALL IRRIGATION PER PLAN FOR VALVE 1A THRU 14A INSTALLATION OF SPRINKLERS, LATERALS, AND EQUIPMENT. TIE TO PHASE 1 CONTROLLER.

NO PERMANENT STRUCTURES OR TREES WITHIN CVOID AND/OR EASEMENTS. CVOID WILL NOT BE RESPONSIBLE FOR DAMAGE OR REPLACEMENT OF ANY SURFACE IMPROVEMENTS, INCLUDING BUT NOT LIMITED TO, DECORATIVE CONCRETE, LANDSCAPING, CURB, GUTTER, SIDEWALKS, PLANTERS, GATES AND RELATED IMPROVEMENTS INSTALLED WITHIN THE CVOID AND/OR USER.

THESE PLANS HAVE BEEN REVIEWED BY THE COACHELLA VALLEY WATER DISTRICT IN ACCORDANCE WITH CALIFORNIA GOVERNMENT CODE, SECTION 65951 ET SEQ. REQUIRING EFFICIENT LANDSCAPE AND IRRIGATION DESIGN IN COOPERATION WITH THE LOCAL GOVERNING AGENCY (CITY AND COUNTY).

APPROVAL OF THIS DRAWING BY CVOID STAFF DOES NOT CONSTITUTE APPROVAL TO ENCRoACH INTO DISTRICT AND USER RIGHT OF WAY. TREES, PLANTS, WALLS AND PERMANENT STRUCTURE OF ANY KIND MAY NOT BE PLANTED OR INSTALLED IN CVOID AND USER EASEMENTS OR RIGHT-OF-WAY WITHOUT FIRST OBTAINING AN ENCROACHMENT PERMIT FROM CVOID.

DATE _____ WATER MANAGEMENT DEPARTMENT _____
 CVOID PLAN NO. _____ DEVELOPMENT SERVICES DEPARTMENT _____

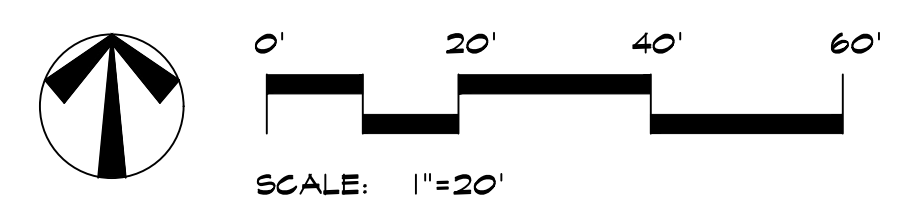

PALM DR.

EQUIPMENT LEGEND			
SYMBOL	MANUFACTURER/MODEL *	SIZE	DETAIL / SHEET
	EXISTING IRRIGATION WATER METER. PROTECT IN PLACE	-	-
	NIBCO T-580 BALL VALVE - FULL PORT	LINE SIZE	C / L1.2
	RAINBIRD PEB SERIES REMOTE CONTROL VALVE	PER PLAN	H / L1.2
	RAINBIRD ESP-LXME/F AUTOMATIC IRRIGATION CONTROLLER WITH IQ NCC SS CARTRIDGE AND COMMUNICATION ANTENNA / INSTALL IN STRONGBOX ENCLOSURE MODEL: SB-24SS. INSTALL PER MANUFACTURER'S SPEC.	36	E / L1.2
	EXISTING BACKFLOW PREVENTER. PROTECT IN PLACE	-	-
	RAINBIRD FS10P FLOW SENSOR	1 1/2"	J / L1.3
	GRISWOLD 2000 SERIES MASTER VALVE	2"	I / L1.3
	RAINBIRD 44-RC QUICK COUPLING VALVE	1"	F / L1.2
NOT SHOWN	UF DIRECT BURIAL CONTROL WIRE #12 GA. COMMON, #14 GA. PILOT W/ PIPE SLEEVE	-	B / L1.2
	PVC SCH 40 FOR 1 1/2" AND SMALLER, PVC CLASS B15 FOR 2"-3". PRESSURE MAINLINE -18' DEEP. PVC C900 FOR 4" AND LARGER. PRESSURE MAINLINE -36' DEEP	PER PLAN	B / L1.2
	SCH 40 PVC NON-PRESSURE LATERAL LINE. 12" DEEP.	PER PLAN	B / L1.2
	SCH 40 PVC WIRE AND PIPE SLEEVES	2x LINE SIZE	A / L1.2

SPRINKLER LEGEND									
SYMBOL	MANUFACTURER/MODEL #	NOZZLE	RAD.	PSI	FLOW (GPM)			DETAIL / SHEET	
					Q	H	F / VAN		
	RAINBIRD 1206-SAM-PRS-10	Q/H/F/V	10'	30	39	7.9	1.58	1.18	D / L1.2
	RAINBIRD 1206-SAM-PRS-12	Q/H/F/V	12'	30	65	1.30	2.6	2.7	
	RAINBIRD 1206-SAM-PRS-15	Q/H/F/V	15'	30	92	1.85	3.7	2.77	
	HUNTER 1-20-06-SS NOZZLES: 3.0 BLUE STR. NOZZLES: 4.0 BLUE HALF	Q/H	35'	35	2.7	3.5			
	HUNTER 1-20-06-SS NOZZLES: 3.0 BLUE FULL	F	35'	35			7		

POINT OF CONNECTION: A
 CONTRACTOR SHALL MAKE POINT OF CONNECTION DOWNSTREAM OF EXISTING METER AND BACKFLOW.
 CONTRACTOR TO VERIFY FINAL LOCATION OF EXISTING METER AND EXISTING BACKFLOW IN FIELD.
 STATIC PRESSURE: FIELD VERIFY
 DESIGN PRESSURE: 15 PSI
 MAXIMUM DEMAND: 44 GPM

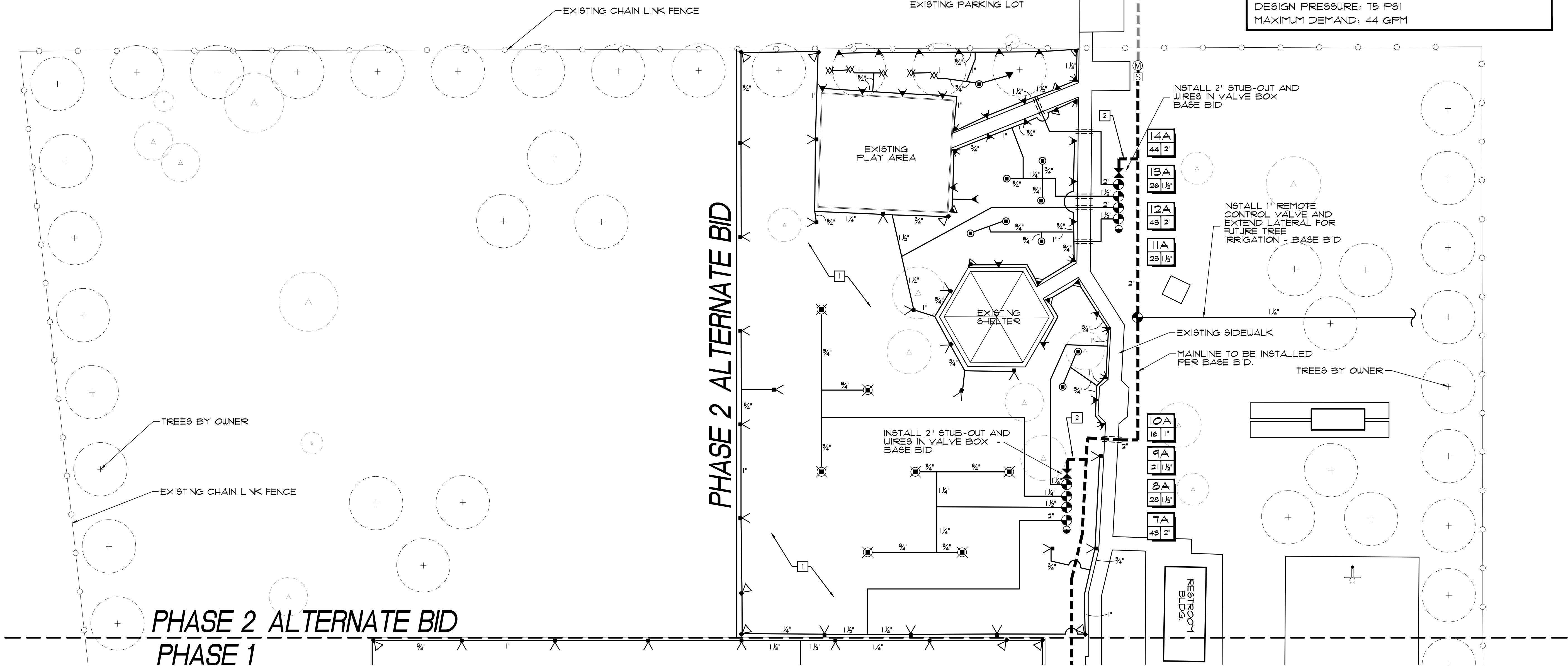

BID ALTERNATE SCHEDULE

BID ITEM	SYMBOL	DESCRIPTION	COMMENTS
1	2	PHASE 2 IRRIGATION 25557 S.F.	INSTALL IRRIGATION PER PLAN FOR VALVE 7A THRU 14A INSTALLATION OF SPRINKLERS, LATERALS, AND EQUIPMENT. TIE TO PHASE 1 CONTROLLER.

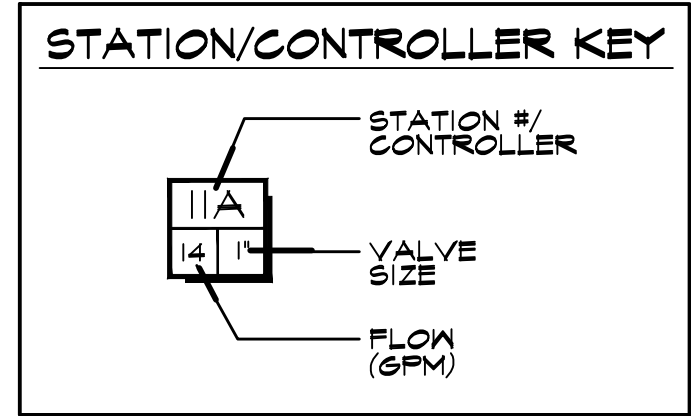

SCHEDULE 40 PVC PIPE SIZING CHART

1 - 7	GPM	3/4"
8 - 12	GPM	1"
13 - 21	GPM	1 1/4"
22 - 29	GPM	1 1/2"
30 - 49	GPM	2"
50 - 69	GPM	2 1/2"
70 - 109	GPM	3"

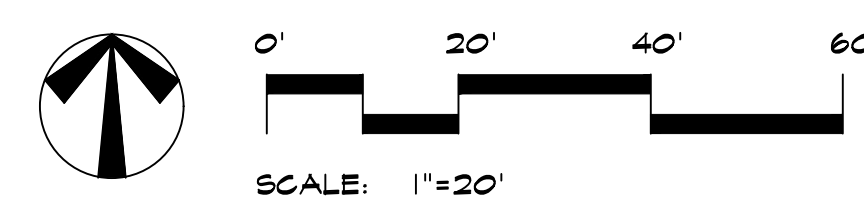

NO PERMANENT STRUCTURES OR TREES WITHIN CIVID AND/OR EASEMENTS. CIVID WILL NOT BE RESPONSIBLE FOR DAMAGE OR REPLACEMENT OF ANY SURFACE IMPROVEMENTS, INCLUDING BUT NOT LIMITED TO, DECORATIVE CONCRETE, LANDSCAPING, CURBS, GUTTERS, SIDEWALKS, PLANTERS, GATES AND RELATED IMPROVEMENTS INSTALLED WITHIN THE CIVID AND/OR USER.

THESE PLANS HAVE BEEN REVIEWED BY THE COACHELLA VALLEY WATER DISTRICT IN ACCORDANCE WITH CALIFORNIA GOVERNMENT CODE, SECTION 65959 ET SEQ. REQUIRING EFFICIENT LANDSCAPE AND IRRIGATION DESIGN IN COOPERATION WITH THE LOCAL GOVERNING AGENCY (CITY AND COUNTY).

APPROVAL OF THIS DRAWING BY CIVID STAFF DOES NOT CONSTITUTE APPROVAL TO ENCRoACH INTO DISTRICT AND USER RIGHT OF WAY. TREES, PLANTS, WALLS AND PERMANENT STRUCTURE OF ANY KIND MAY NOT BE PLANTED OR INSTALLED IN CIVID AND USER EASEMENTS OR RIGHT-OF-WAY WITHOUT FIRST OBTAINING AN ENCROACHMENT PERMIT FROM CIVID.

DATE: _____ WATER MANAGEMENT DEPARTMENT
 CIVID PLAN NO. _____ DEVELOPMENT SERVICES DEPARTMENT

HERMANN DESIGN GROUP
 77-899 WOLF RD.
 SUITE 102
 PALM DESERT, CA 92211
 LIC# 2754 EXP. 04/30/24
 PH. (760) 777-9131
 FAX (760) 777-9132

OWNER: SALTON COMMUNITY SERVICES DISTRICT
 1209 VAN BUREN AVENUE
 THERMAL, CA 92274
 OFFICE (760) 394-4446

PROJECT: DESERT SHORES SOCCER PARK
 001-155-001
 THERMAL CA, 92274

REVISIONS	DATE	BY

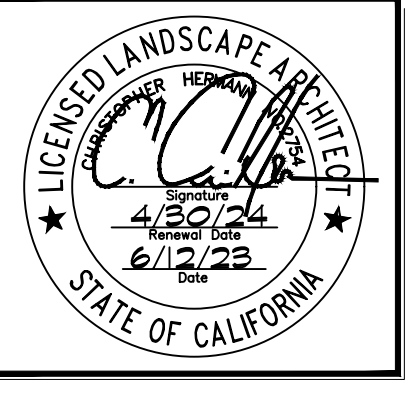

SHEET TITLE
IRRIGATION PLAN

DESIGNED	JE
DRAWN	JE
CHECKED	CH
DATE	6/20/23
SCALE	1"=20'
JOB NO.	23013

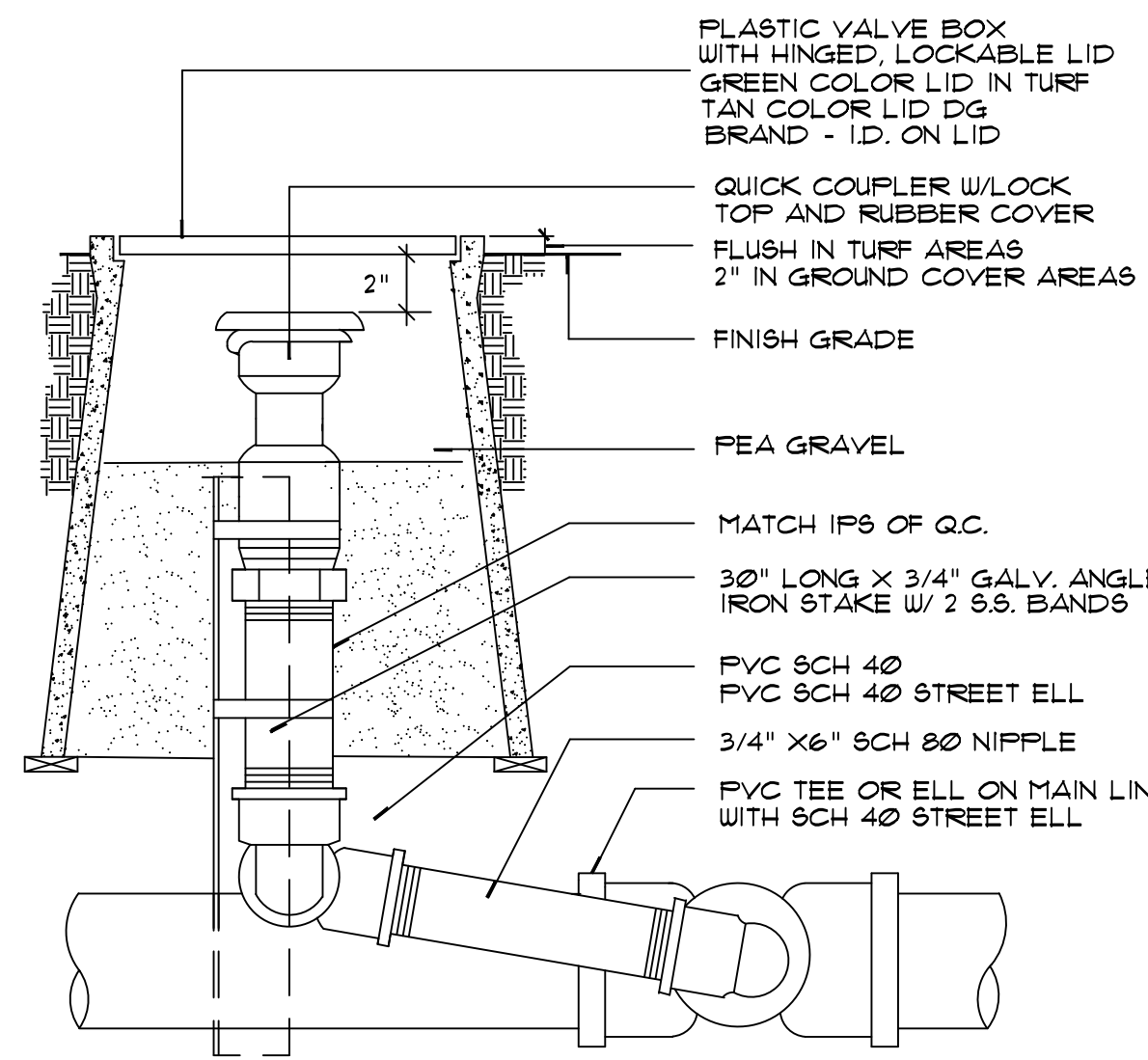

F QUICK COUPLER

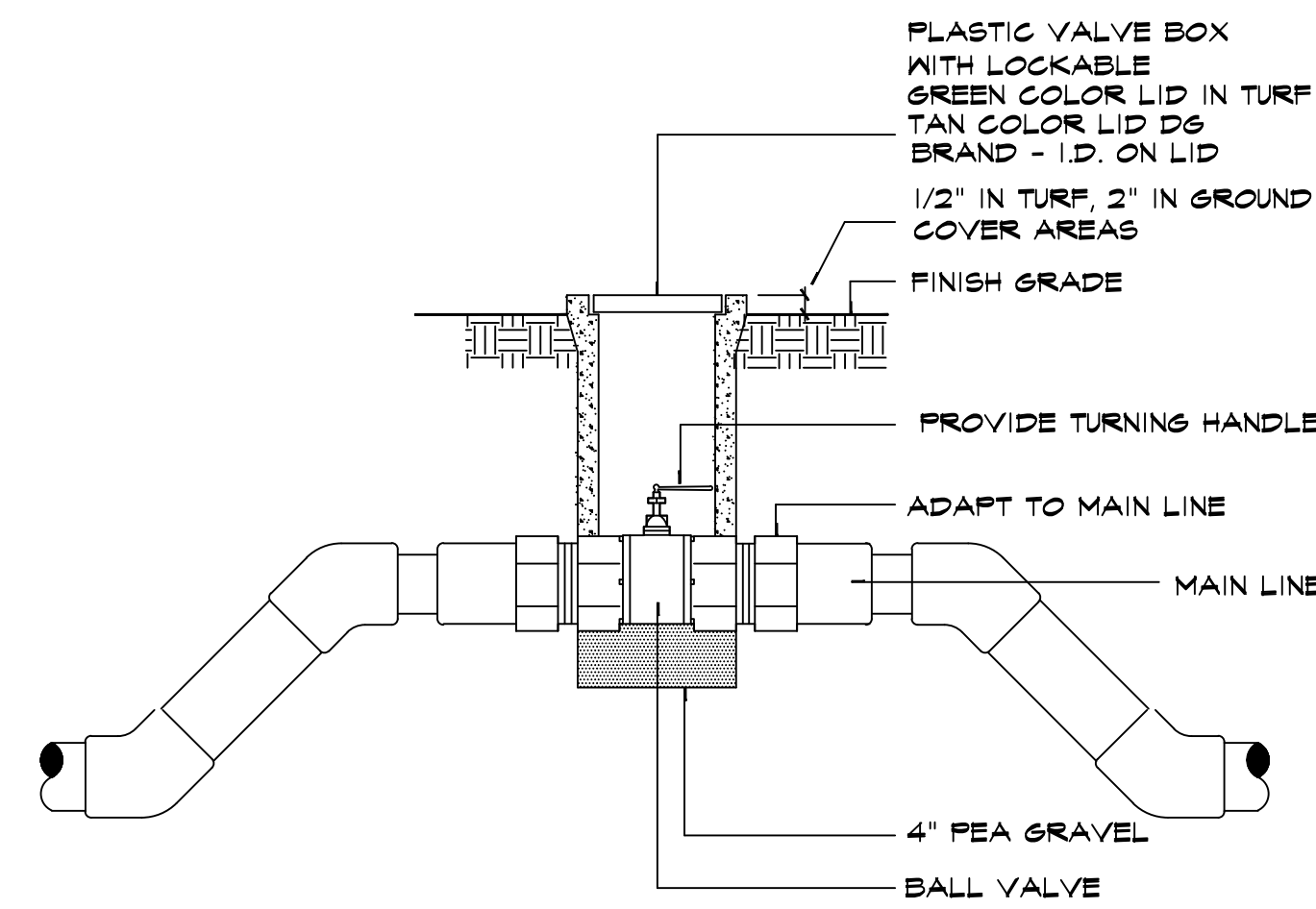

C BALL VALVE (FULL PORT)

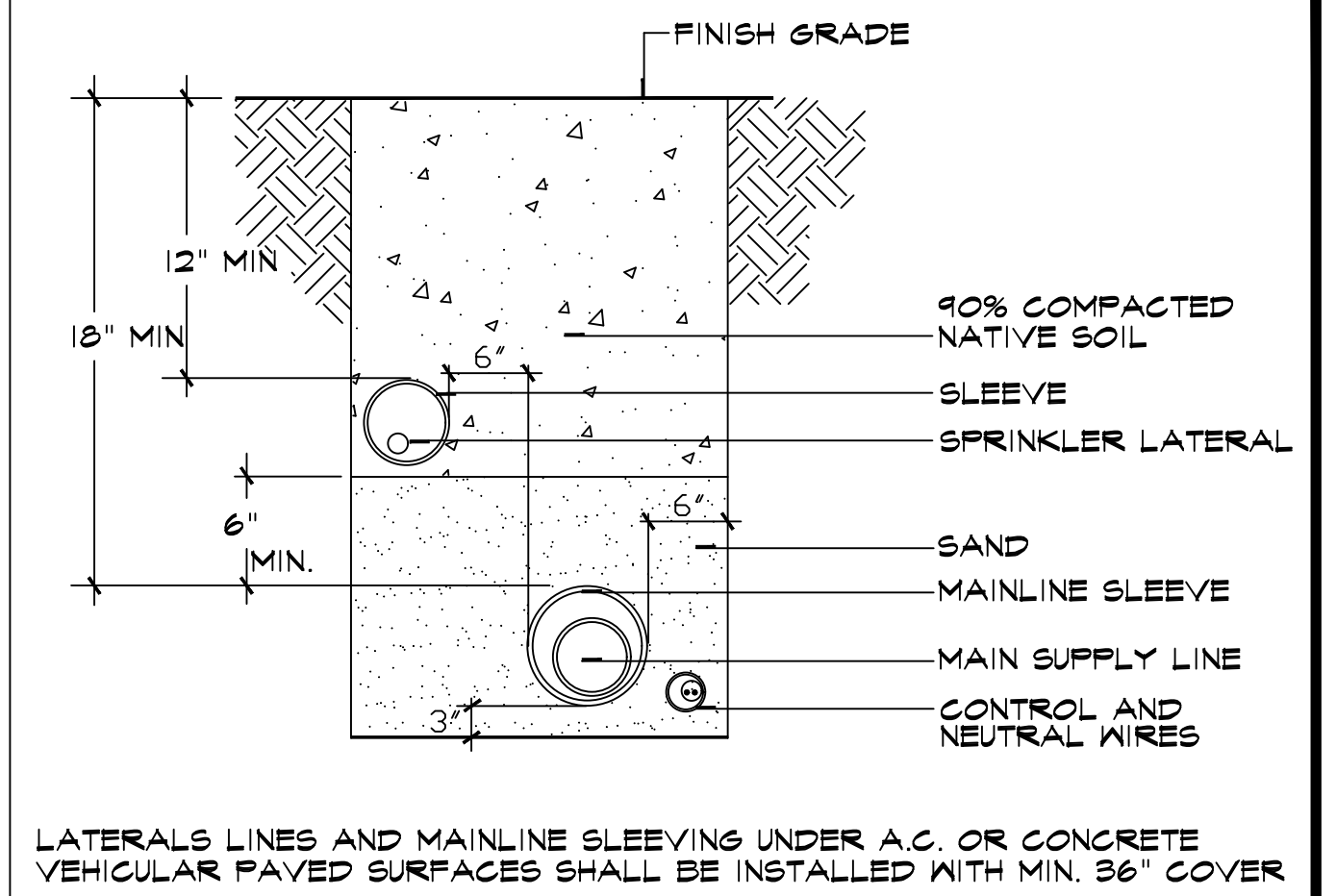

A SLEEVING

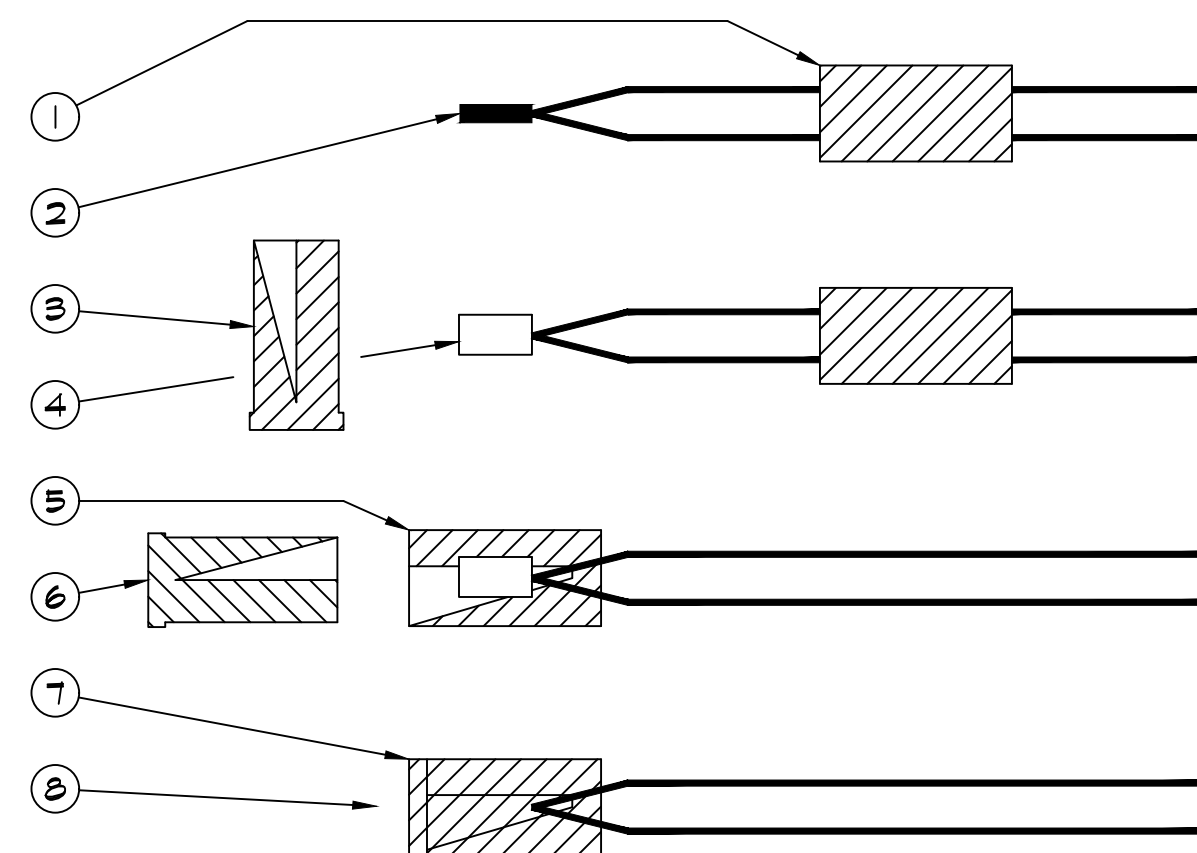

1. SLIP BASE SOCKET OVER END OF WIRES
2. STRIP WIRES APPROX. 3/8" FROM ENDS - TWIST TOGETHER
3. APPLY SEALER TO OUTSIDE OF SEALING PLUG AND FILL CAVITY WITH SEALER
4. PUT CRIMP END OVER WIRE ENDS - CRIMP SLEEVE AND CUT OFF EXCESS WIRE
5. FULL BASE SOCKET OVER END OF WIRES AS FAR AS POSSIBLE
6. PUSH SEALING PLUG INTO BASE SOCKET
7. PUSH WIRES TO END OF BASE SOCKET TO INSURE COMPLETE SEALING OF CONNECTION
8. COMPLETED WATERPROOF WIRE CONNECTION

G WIRE CONNECTION

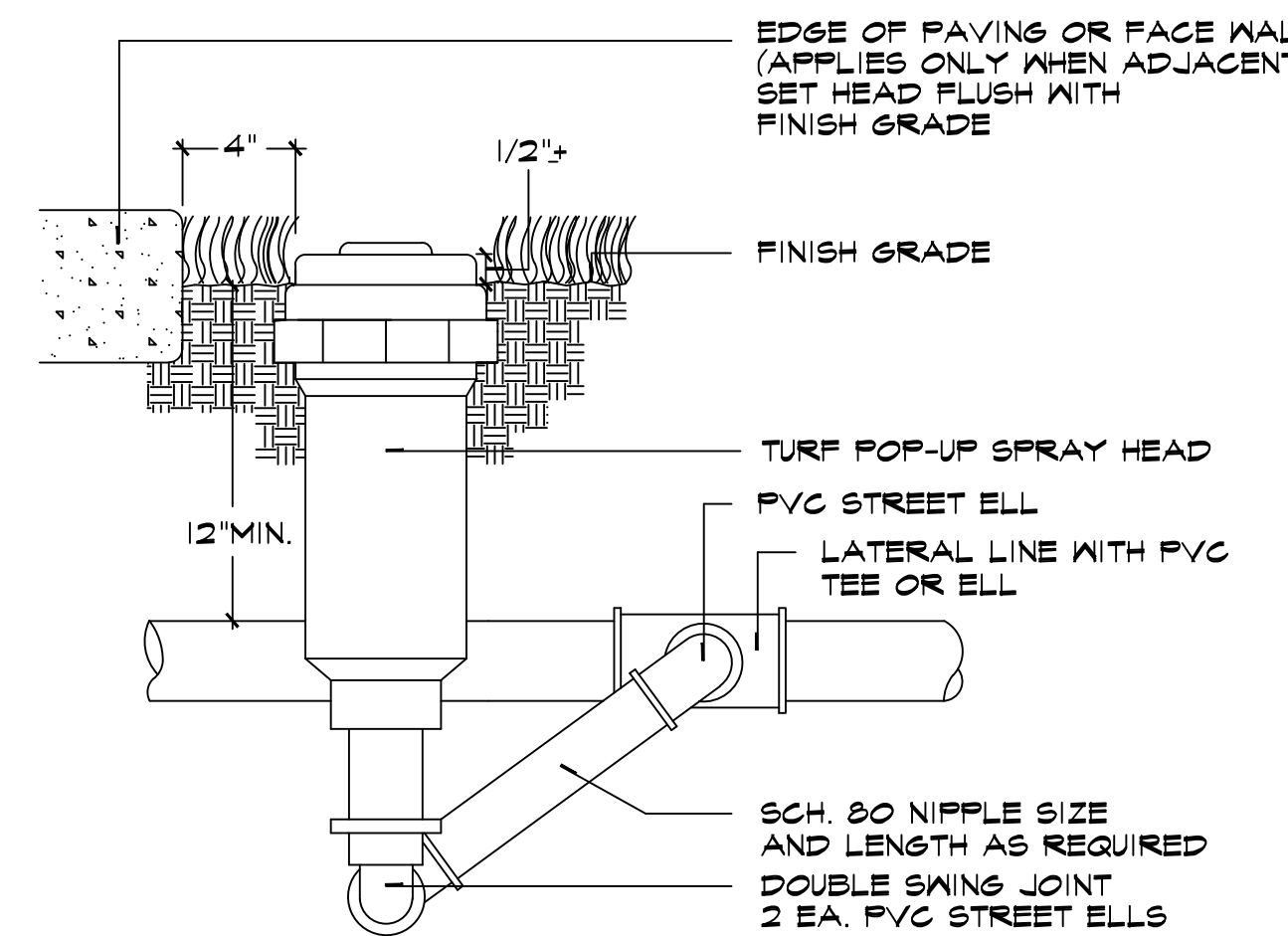

D SPRAY / ROTOR POP-UP HEAD

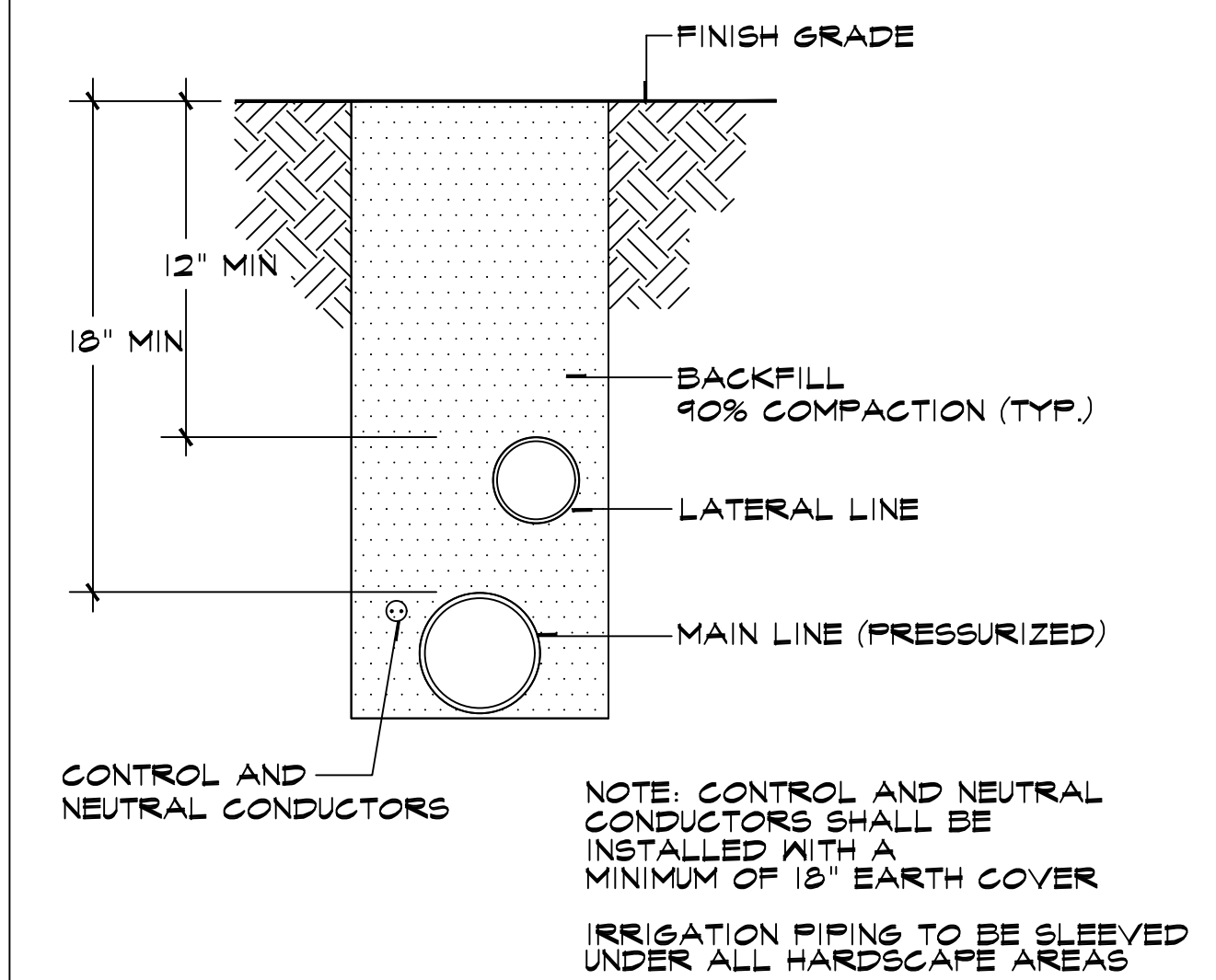

B TRENCHING

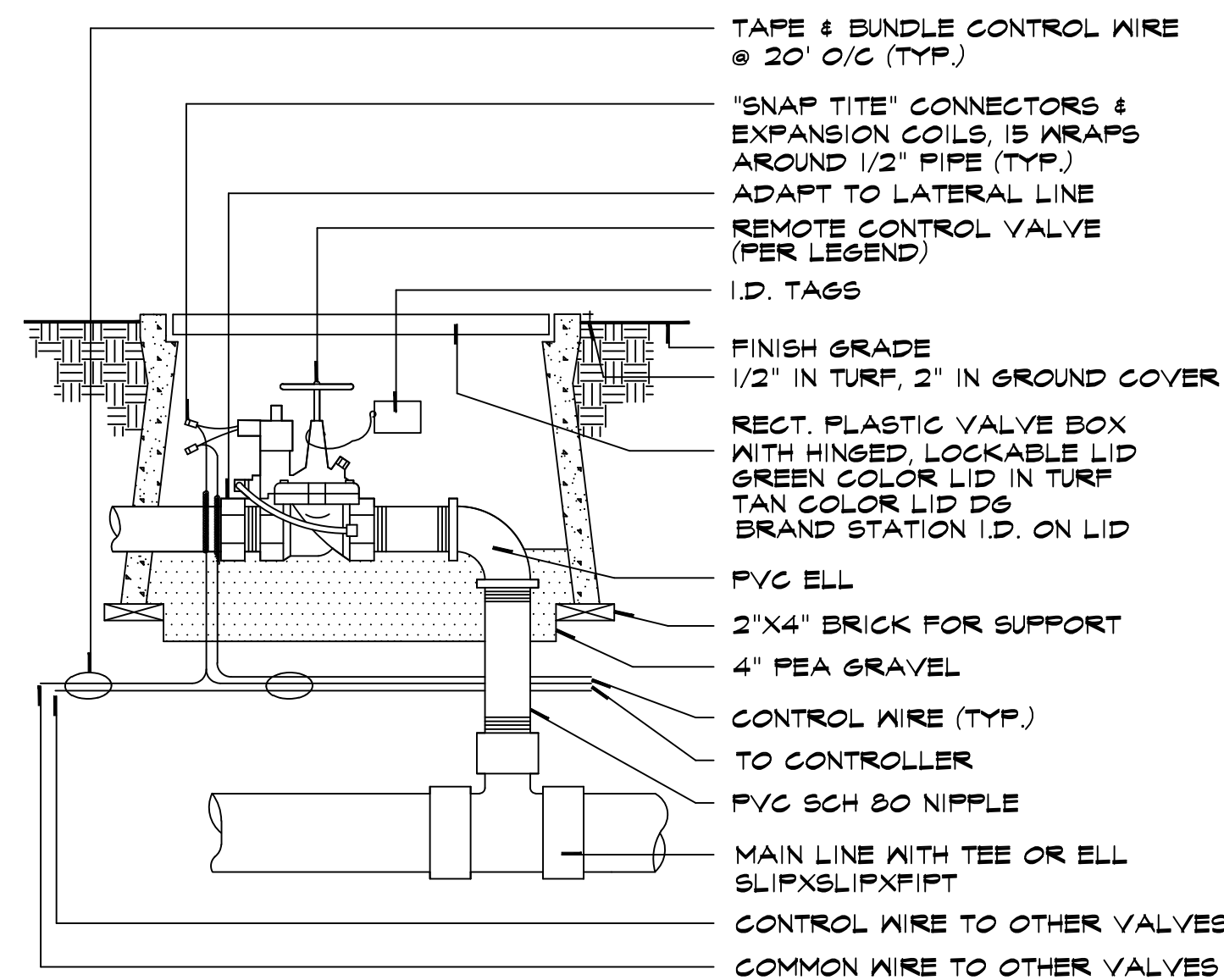

H REMOTE CONTROL VALVE

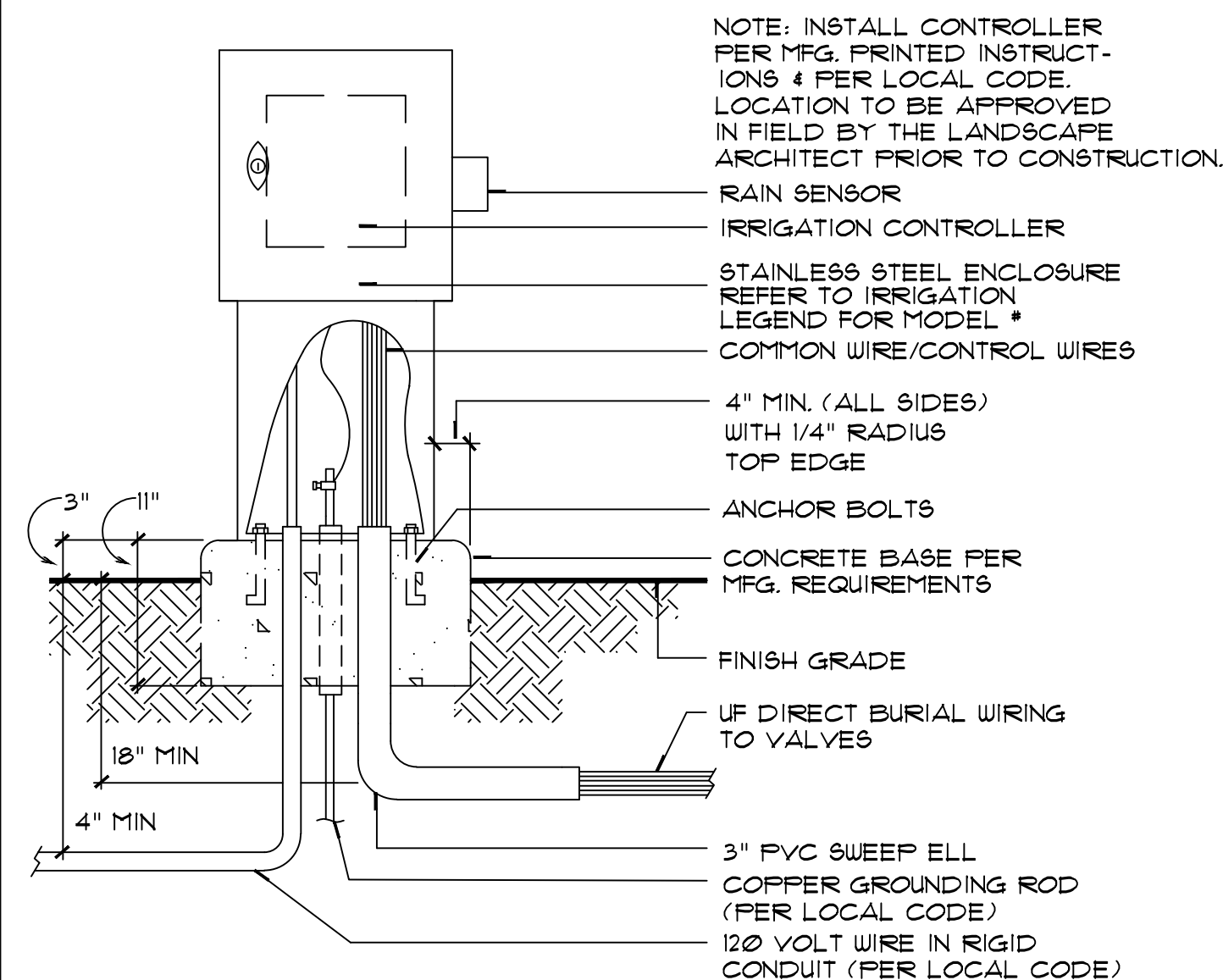

E CONTROLLER

NO PERMANENT STRUCTURES OR TREES WITHIN CVOID AND/OR EASEMENTS. CVOID WILL NOT BE RESPONSIBLE FOR DAMAGE OR REPLACEMENT OF ANY SURFACE IMPROVEMENTS, INCLUDING BUT NOT LIMITED TO, DECORATIVE CONCRETE, LANDSCAPING, CURBS, GUTTERS, SIDEWALKS, PLANTERS, GATES AND RELATED IMPROVEMENTS INSTALLED WITHIN THE CVOID AND/OR USER.

THESE PLANS HAVE BEEN REVIEWED BY THE COACHELLA VALLEY WATER DISTRICT IN ACCORDANCE WITH CALIFORNIA GOVERNMENT CODE, SECTION 65951 ET SEQ. REQUIRING EFFICIENT LANDSCAPE AND IRRIGATION DESIGN IN COOPERATION WITH THE LOCAL GOVERNING AGENCY (CITY AND COUNTY).

APPROVAL OF THIS DRAWING BY CVOID STAFF DOES NOT CONSTITUTE APPROVAL TO ENCRoACH INTO DISTRICT AND USBR RIGHT OF WAY. TREES, PLANTS, WALLS AND PERMANENT STRUCTURE OF ANY KIND MAY NOT BE PLANTED OR INSTALLED IN CVOID AND USBR EASEMENTS OR RIGHT-OF-WAY WITHOUT FIRST OBTAINING AN ENCROACHMENT PERMIT FROM CVOID.

DATE _____ WATER MANAGEMENT DEPARTMENT _____
 CVOID PLAN NO. _____ DEVELOPMENT SERVICES DEPARTMENT _____



HERMANN DESIGN GROUP
 77-899 WOLF RD.
 SUITE 102
 PALM DESERT, CA 92211
 LIC# 2754 EXP. 04/30/24
 PH. (760) 777-9131
 FAX (760) 777-9132

OWNER: SALTON COMMUNITY SERVICES DISTRICT
 1209 VAN BUREN AVENUE
 THERMAL, CA 92274
 OFFICE (760) 394-4446

PROJECT: DESERT SHORES SOCCER PARK
 001-155-001
 THERMAL CA, 92274

REVISIONS	DATE	BY



SHEET TITLE
IRRIGATION DETAILS

DESIGNED JE
 DRAWN JE
 CHECKED CH
 DATE 6/20/23
 SCALE N.T.S.
 JOB NO. 23013

SHEET
L1.2
 OF 9 SHEETS

POINT OF CONNECTION: A

ZONE 4: 76"

ESTIMATED ANNUAL APPLIED WATER USE

REC. TURF HIGH - ROTOR

$$ETO \times PF \times LA \times 0.62 / 748 / IE = EAAMU$$

$$76.0 \times .70 \times 53,204 \times 0.62 / 748 / .80 = 2,932.62$$

REC. TURF HIGH - SPRAY

$$ETO \times PF \times LA \times 0.62 / 748 / IE = EAAMU$$

$$76.0 \times .70 \times 53,17 \times 0.62 / 748 / .75 = 3126.1$$

MAXIMUM ANNUAL APPLIED WATER USE

$$ETO \times 0.62 [(ETAF \times LA) + ((1-ETAF) \times SLA)] / 748 = MAAMU$$

$$76.0 \times 0.62 [(.45 \times 53,521) + ((.55) \times 53,521)] / 748 = 3,686.51$$

ESTIMATED ANNUAL APPLIED WATER USE TOTAL - 3,245.23

MAXIMUM ANNUAL APPLIED WATER USE TOTAL - 3,686.51

ESTIMATED LANDSCAPE SQUARE FT. TOTAL - 53,521

PROJECT INFORMATION

PROJECT NAME	DESERT SHORES PARK	PHONE NO.	(760) 777-4131
NAME OF PROJECT APPLICANT	JOSE ESTRADA	FAX NO.	(760) 777-4132
TITLE IRRIGATION DESIGNER		EMAIL ADDRESS	JOSE@HDS-INC.COM
COMPANY NAME	HERMANN DESIGN GROUP	STREET ADDRESS	71849 WOLF ROAD
CITY	PALM DESERT	STATE	CA
		ZIP CODE	92211

IRRIGATION POINT OF CONNECTION: EXISTING METER

CONTROLLER NO.	VALVE NO.	PLANT TYPE	IRRIGATION METHOD	AREA SF	PERCENT OF LANDSCAPE AREA
A	1	HIGH	ROTOR	6103	10.4
A	2	HIGH	ROTOR	6222	10.6
A	3	HIGH	ROTOR	6237	10.7
A	4	HIGH	ROTOR	5385	10.1
A	5	HIGH	ROTOR	4338	7.4
A	6	HIGH	ROTOR	4473	7.6
A	7	HIGH	ROTOR	6081	8.3
A	8	HIGH	ROTOR	4648	7.9
A	9	HIGH	ROTOR	3140	5.4
A	10	HIGH	SPRAY	1308	2.2
A	11	HIGH	SPRAY	1264	2.2
A	12	HIGH	ROTOR	5790	9.9
A	13	HIGH	SPRAY	1388	2.4
A	14	HIGH	SPRAY	1644	4.9
TOTAL				53,521	100%

WATER CONSERVATION CONCEPT STATEMENT

Project Site: DESERT SHORES PARK Tract or Parcel Number: P.O.C. A

Project location: THERMAL, CA

Landscape Architect/Irrigation Designer/ Contractor: HERMANN DESIGN GROUP, INC.

Included in this project submittal package are: (Check to indicate completion)

- 1. Maximum Annual Applied Water allowance:
Conventional Landscape: N/A 100 cubic feet/year
+ Recreational Turfgrass Landscape: 3,686.51 100 cubic feet/year (if applicable)
Maximum Annual Applied Water Allowance: 3,686.51 100 cubic feet/year
- 2. Estimated Annual Applied Water Use by Hydrozone:
Turfgrass Hydrozones: N/A 100 cubic feet/year
Recreational Turfgrass Hydrozones: 3,245.23 100 cubic feet/year
Very Low Plant Hydrozones: N/A 100 cubic feet/year
Low Plant Hydrozones: N/A 100 cubic feet/year
Medium Plant Hydrozones: N/A 100 cubic feet/year
High Plant Hydrozones: N/A 100 cubic feet/year
Water Features: N/A 100 cubic feet/year
Other: N/A 100 cubic feet/year
Estimated Annual Total Applied Water Use: 3,245.23 100 cubic feet/year
REFER TO CALCULATIONS ON IRRIGATION PLAN
- 3. EATAMU < MAAMU
- 4. Landscape Design Plan
- 5. Irrigation Design Plan
- 6. Grading Design Plan
- 7. Soil Chemical Analysis (optional)

Description of Project: (Briefly describe the planning and design actions that are intended to achieve conservation and efficiency in water use.)

THE IRRIGATION SYSTEM IS DESIGNED FOR EFFICIENT PERFORMANCE WITH CONSERVATION IN MIND. POINT SOURCE DRIP / BUBBLER SYSTEMS PROVIDE DIRECT WATER TO THE SHRUBS AND TREES.

Date: 6/7/23 Prepared by: JOSE ESTRADA

IRRIGATION NOTES

- GENERAL - ALL WORK SHALL BE DONE IN ACCORDANCE WITH APPLICABLE CITY CODES, AND THESE PLANS.
 - THE CONTRACTOR SHALL CAREFULLY REVIEW THE SITE AND VERIFY ALL CONDITIONS AND DIMENSIONS PRIOR TO PROCEEDING WITH ANY WORK UNDER THIS CONTRACT.
 - THE CONTRACTOR SHALL CARRY ALL WORKERS PUBLIC LIABILITY, AND PROPERTY DAMAGE INSURANCE AS REQUIRED BY OWNER.
 - THE CONTRACTOR SHALL APPLY FOR ALL PERMITS AND PAY FOR SAME.
- SCOPE OF WORK - UNLESS OTHERWISE SPECIFIED, THE CONSTRUCTION OF IRRIGATION SYSTEMS SHALL INCLUDE THE FURNISHING, INSTALLING AND TESTING OF ALL MAIN LINE, POINT OF CONNECTION, LATERAL LINE, RISERS AND FITTINGS, AND THE FURNISHING AND INSTALLING OF SPRINKLER HEADS, AUTOMATIC CONTROLLERS, CONTROL WIRES (TO VALVES), ELECTRICAL CONTROL VALVES, BACKFLOW PROTECTION, EXCAVATION AND BACKFILL AND ALL OTHER WORK IN ACCORDANCE WITH THESE PLANS, DETAILS AND NOTES.

THE CONTRACTOR SHALL FURNISH ALL LABOR, MATERIALS, EQUIPMENT, PROPERTY, TRANSPORTATION AND PERFORM ALL OPERATIONS REQUIRED FOR A COMPLETE AND OPERABLE IRRIGATION SYSTEM AS INDICATED ON, OR REASONABLY IMPLIED BY THE DRAWINGS AND/OR NOTES INCLUDED AS A PART OF THE IRRIGATION WORK, BUT NOT LIMITED BY IT, ARE THE FOLLOWING ITEMS:

 - INSTALL COMPLETE OPERABLE INDEPENDENT, AUTOMATIC, IRRIGATION SYSTEMS PER THE PLANS, DETAILS, LEGEND AND NOTES.
 - ALL IRRIGATION WORK SHALL BE GUARANTEED BY THE CONTRACTOR AS TO MATERIALS AND WORKMANSHIP, INCLUDING SETTling OF BACKFILLED TRENCHES BELOW GRADE FOR A PERIOD OF ONE YEAR FOLLOWING THE DATE OF FINAL ACCEPTANCE OF THE WORK.

- THE LANDSCAPE ARCHITECT SHALL DECIDE ALL QUESTIONS RELATING TO INTERPRETATION OF THE DRAWINGS AND THE ACCEPTABLE FULFILLMENT OF THE CONTRACT.
- PIPING SHOWN ON THE PLANS IS ESSENTIALLY DIAGRAMMATIC. CONTRACTOR SHALL ROUTE PIPING TO AVOID CONFLICT WITH STATIONARY ELEMENTS AND IN SUCH A MANNER AS TO CONFORM WITH THE VARIOUS DETAILS.
- THE CONTRACTOR SHALL AT ALL TIMES PROTECT HIS WORK FROM DAMAGE AND THEFT AND REPLACE ALL DAMAGED OR STOLEN PARTS AT HIS EXPENSE UNTIL THE WORK IS ACCEPTED IN WRITING BY THE OWNER.
- EXTREME CARE SHALL BE EXERCISED IN EXCAVATING AND WORKING NEAR EXISTING UTILITIES. CONTRACTOR SHALL VERIFY THE LOCATION AND CONDITION OF ALL UTILITIES AND BE RESPONSIBLE FOR ANY DAMAGE. UTILITIES PLANS MAY BE OBTAINED FROM OWNER.
- THE CONTRACTOR SHALL KEEP THE PREMISES CLEAN AND FREE OF EXCESS EQUIPMENT, MATERIALS AND RUBBISH INCIDENTAL TO HIS WORK.
- IRRIGATION DESIGN IS BASED ON 75 PSI OPERATING WATER PRESSURE AT 44 GPM. CONTRACTOR SHALL VERIFY PRESSURE PRIOR TO CONSTRUCTION. SHOULD A DISCREPANCY EXIST, NOTIFY THE LANDSCAPE ARCHITECT PRIOR TO BEGINNING CONSTRUCTION.
- THE CONTRACTOR SHALL BE RESPONSIBLE FOR MAKING ALL CONNECTIONS INTO RESIDENTIAL WATER METER AND SERVICE LINE AS CALLED FOR ON THESE PLANS.
- THE CONTRACTOR SHALL INSTALL VALVES TO MEET ALL APPLICABLE CODES.
- IRRIGATION CONTRACTOR SHALL BE RESPONSIBLE FOR CONNECTING 120 VOLT SERVICE TO THE CONTROLLER. ELECTRICAL POWER SOURCE WILL BE PROVIDED BY THE OWNER WITH A JUNCTION BOX AT THE CONTROLLER LOCATION AS SHOWN ON THE PLAN.
- ALL CONTROL WIRE SHALL BE SOLID COPPER, PLASTIC INSULATED, IF DIRECT BURIAL WIRE, ALL COMMON WIRE SHALL BE AWG #12 WHITE; ALL PILOT WIRE SHALL BE AWG #14, RED OR BLACK.
- ALL CONTROL WIRE AND IRRIGATION LINE RUNS UNDER PAVING SHALL BE ENCASED IN SCH.40 PVC PIPE SLEEVES.
- FINAL LOCATION OF CONTROL VALVES SHALL BE REVIEWED IN THE FIELD BY THE OWNER'S AUTHORIZED REPRESENTATIVE.
- ALL THREADED CONNECTIONS SHALL BE COATED WITH TEFLON TAPE. ALL PVC THREADED CONNECTIONS SHALL BE COATED WITH TEFLON TAPE.
- ALL PVC SOLVENT-WELD CONNECTIONS SHALL BE MADE WITH SOLVENT-WELD MATERIALS AS SPECIFIED ON PLANS. SOLVENT-WELD PRIMER SHALL BE APPLIED AT ALL CONNECTIONS.
- UPON COMPLETION OF THE PROJECT, CONTRACTOR TO TURN OVER TO OWNER:
 - A CONTROLLER CHART FOR EACH CONTROLLER
 - 2 KEYS FOR CONTROLLER.

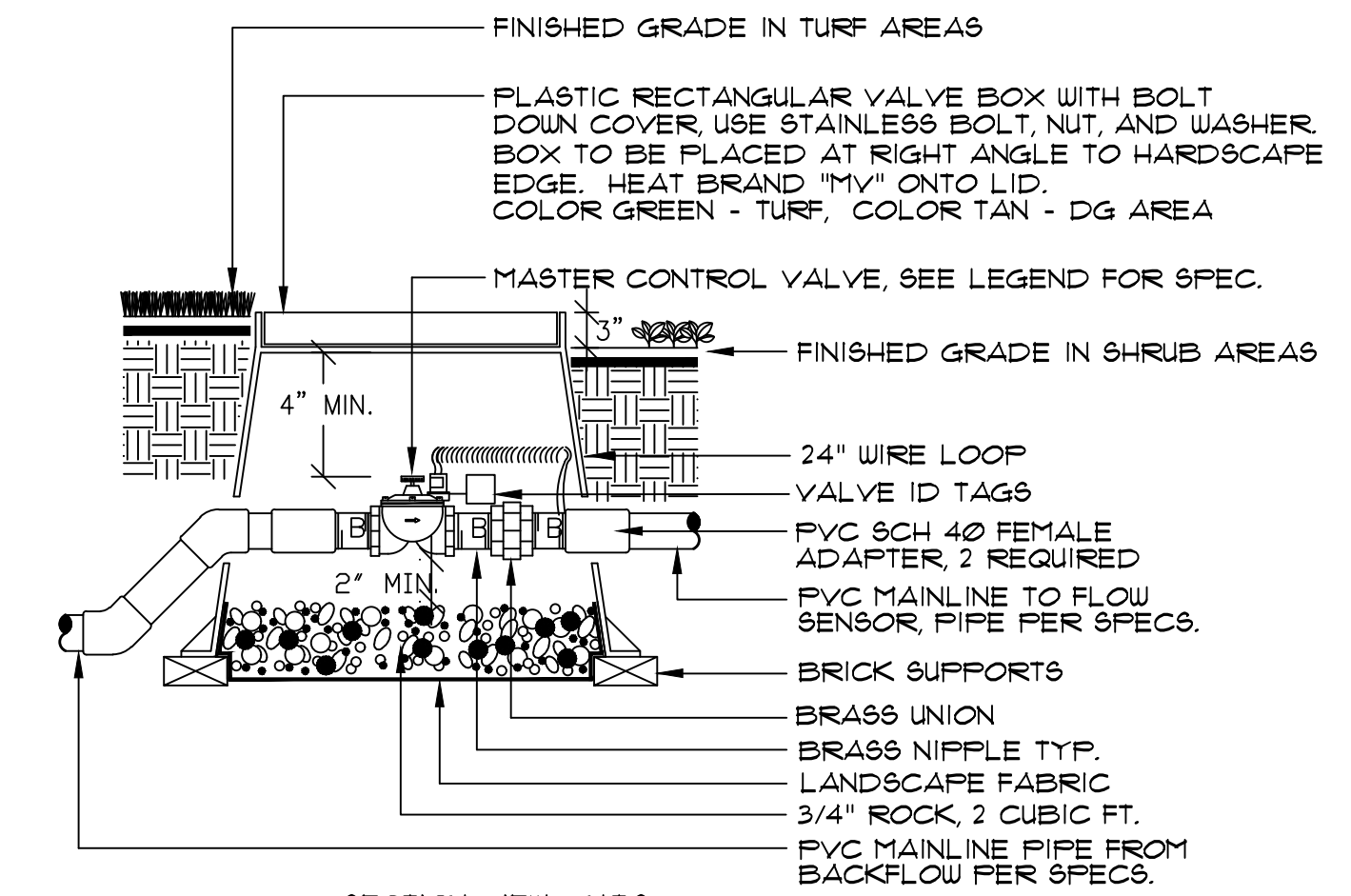

NOTE:
USE 45 DEGREE ELLS TO ACHIEVE MAINLINE DEPTH FROM UP-STREAM SIDE OF THE MASTER VALVE ASSEMBLY.

I MASTER VALVE

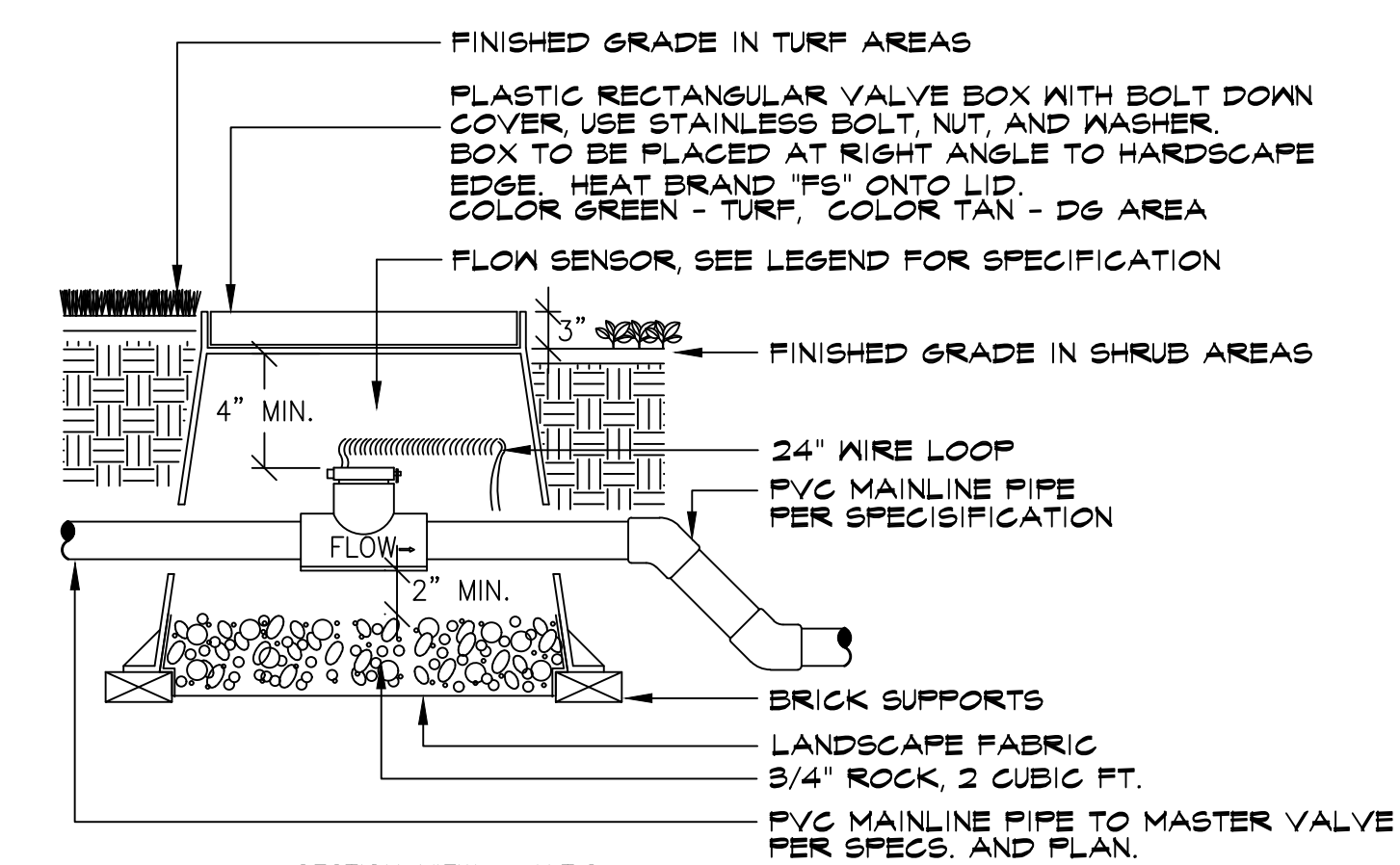

NOTE:
INSTALL FLOW SENSOR AS PER THE MANUFACTURER'S RECOMMENDATIONS, WIRE TO SENSOR DECODER.
USE 45 DEGREE ELLS TO ACHIEVE MAINLINE DEPTH ON THE DOWN-STREAM SIDE OF THE FLOW SENSOR.

J FLOW SENSOR

NO PERMANENT STRUCTURES OR TREES WITHIN CVOID AND/OR EASEMENTS. CVOID WILL NOT BE RESPONSIBLE FOR DAMAGE OR REPLACEMENT OF ANY TREES, PLANTS, WALLS AND PERMANENT STRUCTURE OF ANY KIND MAY SURFACE IMPROVEMENTS, INCLUDING BUT NOT LIMITED TO, DECORATIVE CONCRETE, LANDSCAPING, CURB, GUTTER, SIDEWALKS, PLANTERS, GATES AND RELATED IMPROVEMENTS INSTALLED WITHIN THE CVOID AND/OR USER.

THESE PLANS HAVE BEEN REVIEWED BY THE COACHELLA VALLEY WATER DISTRICT IN ACCORDANCE WITH CALIFORNIA GOVERNMENT CODE, SECTION 65981 ET SEQ. REQUIRING EFFICIENT LANDSCAPE AND IRRIGATION DESIGN IN COOPERATION WITH THE LOCAL WATERING AGENCY (CITY AND COUNTY).

APPROVAL OF THIS DRAWING BY CVOID STAFF DOES NOT CONSTITUTE APPROVAL TO ENCRoACH INTO DISTRICT AND USBR RIGHT OF WAY. TREES, PLANTS, WALLS AND PERMANENT STRUCTURE OF ANY KIND MAY NOT BE PLANTED OR INSTALLED IN CVOID AND USBR EASEMENTS OR RIGHT-OF-WAY WITHOUT FIRST OBTAINING AN ENCROACHMENT PERMIT FROM CVOID.

DATE _____ WATER MANAGEMENT DEPARTMENT _____

CVOID PLAN NO. _____ DEVELOPMENT SERVICES DEPARTMENT _____



HERMANN DESIGN GROUP
77-899 WOLF RD.
SUITE 102
PALM DESERT, CA
92211
LIC# 2754 EXP. 04/30/24
PH. (760) 777-9131
FAX (760) 777-9132

OWNER: SALTON COMMUNITY SERVICES DISTRICT
1209 VAN BUREN AVENUE
THERMAL, CA 92274
OFFICE (760) 384-4446

PROJECT: DESERT SHORES SOCCER PARK
001-155-001
THERMAL CA, 92274

REVISIONS	DATE	BY



SHEET TITLE
IRRIGATION DETAILS

DESIGNED	JE
DRAWN	JE
CHECKED	CH
DATE	6/20/23
SCALE	N.T.S.
JOB NO.	23013

SHEET
L1.3
OF 9 SHEETS



HERMANN DESIGN GROUP
77-899 WOLF RD.
SUITE 102
PALM DESERT, CA
92211

LIC# 2754 EXP. 04/30/24
PH. (760) 777-9131
FAX (760) 777-9132

OWNER:
SALTON COMMUNITY
SERVICES DISTRICT
1209 VAN BUREN AVENUE
THERMAL, CA 92274
OFFICE (760) 394-4446

PROJECT:
DESERT SHORES
SOCCER PARK
001-155-001
THERMAL CA, 92274

REVISIONS	DATE	BY

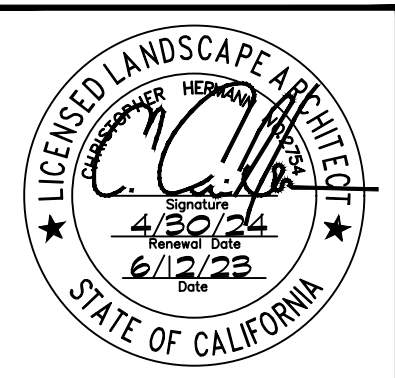

SHEET TITLE
PLANTING PLAN

DESIGNED	JE
DRAWN	JE
CHECKED	CH
DATE	6/20/23
SCALE	1"=20'
JOB NO.	23013

SHEET
L2.0
OF 9 SHEETS

MATCH LINE SEE SHEET L2.1

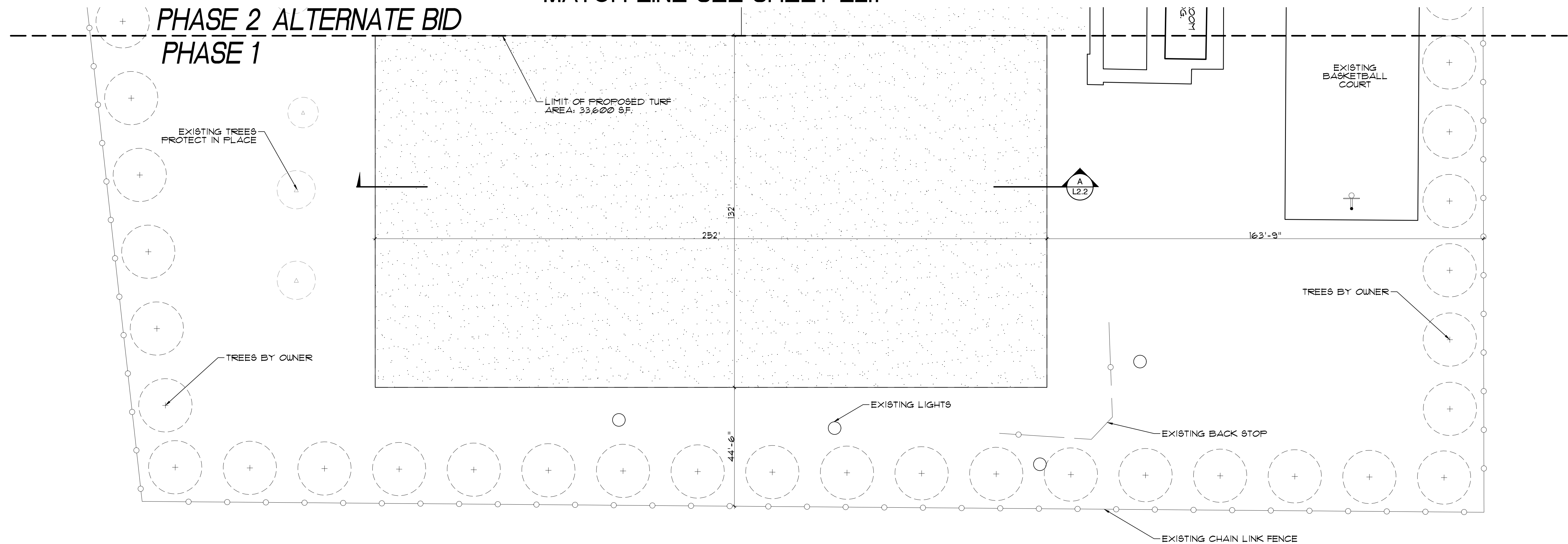

PLANT LIST

SYMBOL	QTY.	BOTANICAL NAME COMMON NAME	SIZE NOTES	WATER USE
--------	------	-------------------------------	---------------	--------------

GROUNDCOVER

	33,600 S.F.	INSTALL TIFWAY HYBRID BERMUDA 419' BERMUDA HYBRID SOD OVERSEED W/ PERENNIAL RYE (OCTOBER-MAY INSTALLATION) BY A.G. SOD REFER TO DETAIL: A / L2.2 FOR SOD EDGE REFER TO SHEET L2.3 FOR SOIL AMENDMENT SPECIFICATIONS
--	-------------	---

BID ALTERNATE SCHEDULE

BID ITEM	SYMBOL	DESCRIPTION	COMMENTS
1		PHASE 2 PLANTING AND IRRIGATION 23557 S.F.	INSTALLATION OF TIFWAY HYBRID BERMUDA 419' BERMUDA HYBRID SOD PER LEGEND OVERSEED W/ PERENNIAL RYE (OCTOBER-MAY INSTALLATION)

NO PERMANENT STRUCTURES OR TREES WITHIN CUID AND/OR EASEMENTS. CUID WILL NOT BE RESPONSIBLE FOR DAMAGE OR REPLACEMENT OF ANY SURFACE IMPROVEMENTS, INCLUDING BUT NOT LIMITED TO, DECORATIVE CONCRETE, LANDSCAPING, CURB, GUTTER, SIDEWALKS, PLANTERS, GATES AND RELATED IMPROVEMENTS INSTALLED WITHIN THE CUID AND/OR USER.

THESE PLANS HAVE BEEN REVIEWED BY THE COACHELLA VALLEY WATER DISTRICT IN ACCORDANCE WITH CALIFORNIA GOVERNMENT CODE, SECTION 65951 ET SEQ. REQUIRING EFFICIENT LANDSCAPE AND IRRIGATION DESIGN IN COOPERATION WITH THE LOCAL GOVERNING AGENCY (CITY AND COUNTY).

APPROVAL OF THIS DRAWING BY CUID STAFF DOES NOT CONSTITUTE APPROVAL TO ENCRoACH INTO DISTRICT AND USER RIGHT OF WAY. TREES, PLANTS, WALLS AND PERMANENT STRUCTURE OF ANY KIND MAY NOT BE PLANTED OR INSTALLED IN CUID AND USER EASEMENTS OR RIGHT-OF-WAY WITHOUT FIRST OBTAINING AN ENCROACHMENT PERMIT FROM CUID.

DATE _____ WATER MANAGEMENT DEPARTMENT
CUID PLAN NO. _____ DEVELOPMENT SERVICES DEPARTMENT

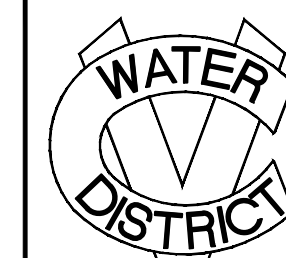
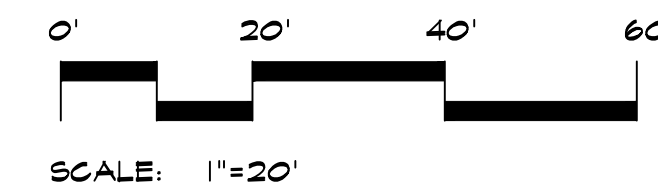
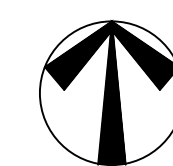

PALM DR.



HERMANN DESIGN GROUP
77-899 WOLF RD.
SUITE 102
PALM DESERT, CA
92211

LIC# 2754 EXP. 04/30/24
PH. (760) 777-9131
FAX (760) 777-9132

OWNER:
SALTON COMMUNITY
SERVICES DISTRICT
1209 VAN BUREN AVENUE
THERMAL, CA 92274
OFFICE (760) 394-4446

PROJECT:
DESERT SHORES
SOCCER PARK
001-155-001
THERMAL CA, 92274

REVISIONS	DATE	BY

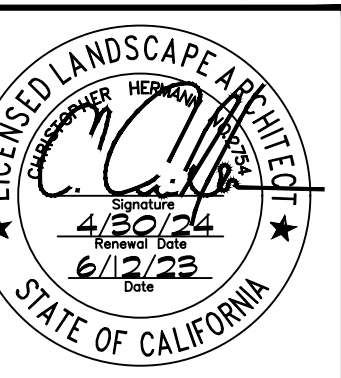

SHEET TITLE
**PLANTING
PLAN**

DESIGNED	JE
DRAWN	JE
CHECKED	CH
DATE	6/20/23
SCALE	1"=20'
JOB NO.	23013

SHEET
L2.1
OF 9 SHEETS

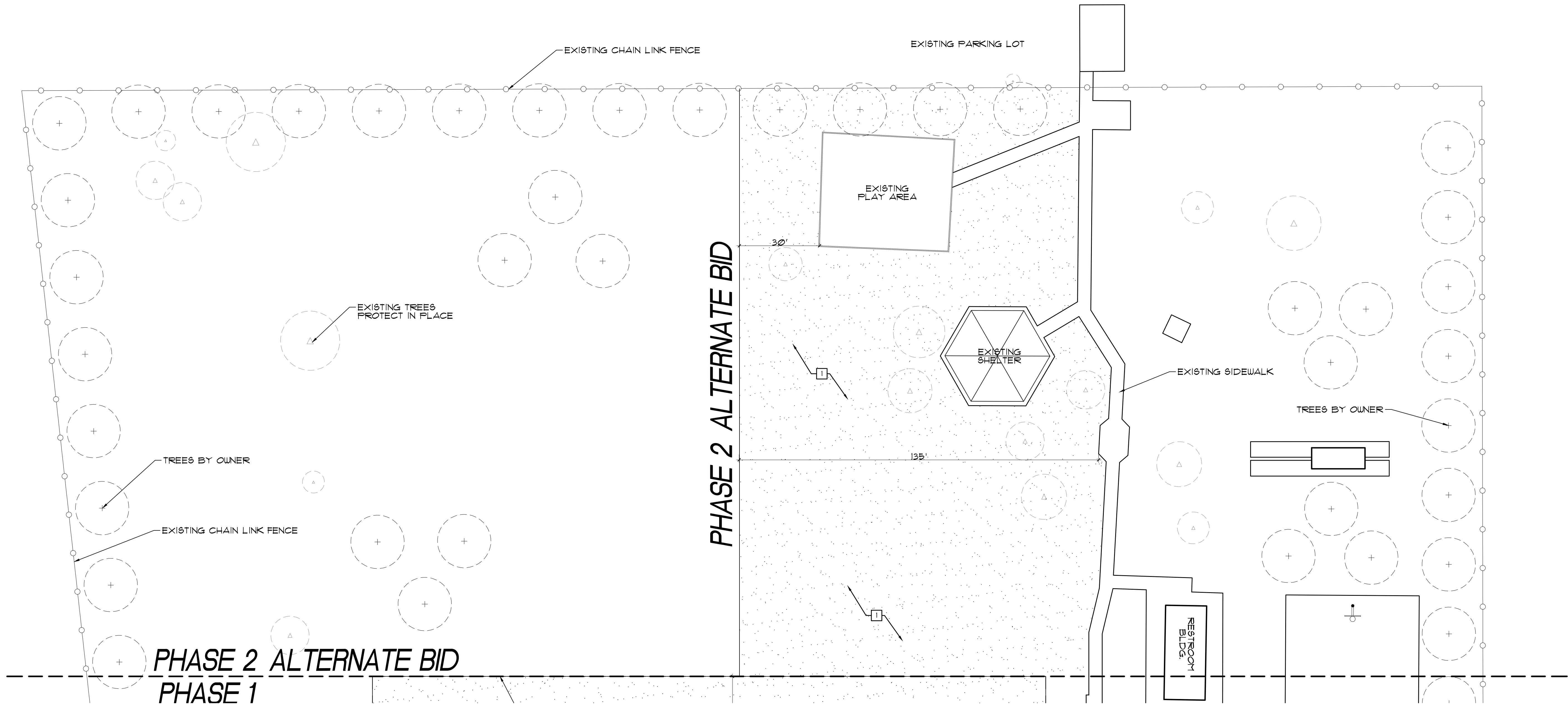

PHASE 2 ALTERNATE BID
PHASE 1

MATCH LINE SEE SHEET L2.0

PLANT LIST

SYMBOL	QTY.	BOTANICAL NAME COMMON NAME	SIZE NOTES	WATER USE
GROUNDCOVER				
	33,600 S.F.	INSTALL TIFWAY HYBRID BERMUDA 419' BERMUDA HYBRID SOD, OVERSEED W/ PERENNIAL RYE (OCTOBER-MAY INSTALLATION) BY A.G. SOD REFER TO DETAIL: A / L2.2 FOR SOD EDGE REFER TO SHEET L2.3 FOR SOIL AMENDMENT SPECIFICATIONS		

BID ALTERNATE SCHEDULE

BID ITEM	SYMBOL	DESCRIPTION	COMMENTS
1		PHASE 2 PLANTING AND IRRIGATION 25,557 S.F.	INSTALLATION OF TIFWAY HYBRID BERMUDA 419' BERMUDA HYBRID SOD PER LEGEND OVERSEED W/ PERENNIAL RYE (OCTOBER-MAY INSTALLATION)

NO PERMANENT STRUCTURES OR TREES WITHIN CIVID AND/OR EASEMENTS.
CIVID WILL NOT BE RESPONSIBLE FOR DAMAGE OR REPLACEMENT OF ANY
SURFACE IMPROVEMENTS, INCLUDING BUT NOT LIMITED TO, DECORATIVE
CONCRETE, LANDSCAPING, CURBS, GUTTER, SIDEWALKS, PLANTERS, GATES
AND RELATED IMPROVEMENTS INSTALLED WITHIN THE CIVID AND/OR USER.

THESE PLANS HAVE BEEN REVIEWED BY THE COACHELLA VALLEY
WATER DISTRICT IN ACCORDANCE WITH CALIFORNIA GOVERNMENT
CODE, SECTION 69991 ET SEQ. REQUIRING EFFICIENT LANDSCAPE
AND IRRIGATION DESIGN IN COOPERATION WITH THE LOCAL
GOVERNING AGENCY (CITY AND COUNTY).

APPROVAL OF THIS DRAWING BY CIVID STAFF DOES NOT CONSTITUTE
APPROVAL TO ENCRUCH INTO DISTRICT AND USER RIGHT OF WAY.
TREES, PLANTS, WALLS AND PERMANENT STRUCTURE OF ANY KIND MAY
NOT BE PLANTED OR INSTALLED IN CIVID AND USER EASEMENTS OR
RIGHT-OF-WAY WITHOUT FIRST OBTAINING AN ENCROACHMENT PERMIT
FROM CIVID.

DATE _____ WATER MANAGEMENT DEPARTMENT _____
CIVID PLAN NO. _____ DEVELOPMENT SERVICES DEPARTMENT _____

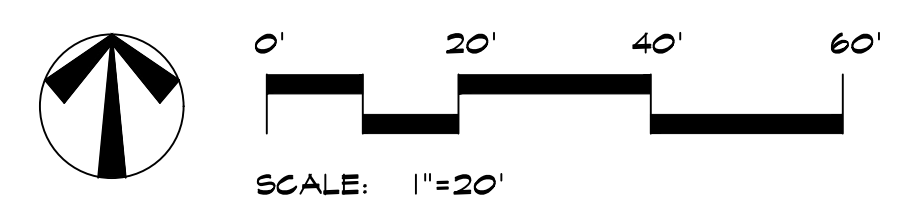

PLANTING NOTES

- SCOPE OF WORK** - FURNISH ALL MATERIAL, LABOR, TRANSPORTATION, EQUIPMENT AND PROPERTY TO COMPLETE THE LANDSCAPING OF THE PLANTING AREAS SHOWN ON THE DRAWINGS, OR REASONABLE IMPLIED TO COMPLETE THE CONSTRUCTION, INCLUDING AS A PART OF THE WORK, BUT NOT NECESSARILY LIMITED BY IT, ARE THE FOLLOWING ITEMS: FINE GRADING OF ALL PLANTING AREAS, PREPARATION OF ALL PLANTING AND TREE HOLES, FURNISHING AND INSTALLATION OF ALL REQUIRED PLANTING BACKFILL MATERIALS, TREE STAKES AND MISCELLANEOUS MATERIALS, FURNISHING AND INSTALLATION OF ALL PLANT MATERIALS, PROVIDING MAINTENANCE THROUGHOUT THE SPECIFIED PERIOD, CLEAN-UP AND WEEDING OF ALL LANDSCAPE AREAS.
- THE CONTRACTOR SHALL REMOVE ALL WEEDS, ROCKS OVER 2" IN DIAMETER, DEBRIS AND OTHER EXTRANEOUS MATERIALS FROM THE JOB SITE IN A LEGAL MANNER PRIOR TO PROCEEDING WITH ANY WORK UNDER THIS CONTRACT.
- THE CONTRACTOR SHALL BE RESPONSIBLE FOR FINISH GRADE, INCLUDING ANY IMPORT SOIL ADJUSTMENTS TO EARTH BERMS, PROVIDE FINISH GRADE IN PLANTING AREAS 1% MINIMUM FLOW. FINISH GRADES SHALL BE 2" BELOW ADJACENT WALKS, CURBS, DRIVEWAYS ETC. IN GROUND COVER AREAS. CONTRACTOR IS RESPONSIBLE FOR ANY EXISTING UNDERGROUND DRAIN LINES TO BE FULLY OPERABLE AT COMPLETION OF JOB. ALL EXISTING ABOVE GROUND DRAIN INLETS SHALL BE RESTORED TO A FULLY OPERABLE CONDITION AT THE CORRECT GRADE TO ENSURE FLOW AS ORIGINALLY INTENDED.
- ALL TREES AND SHRUBS SHALL BE PLANTED PER THESE NOTES AND AS DETAILED. ALL PLANT MATERIAL SHALL BE OF THE HIGHEST QUALITY AND LARGEST REASONABLE SIZE AVAILABLE FOR THE SPECIFIED CONTAINER SIZE (WITHOUT BEING ROOT BOUND); SHRUB MATERIALS SHALL BE VIGOROUSLY GROWING, HEALTHY PLANT MATERIALS, FULL AND BUSHY, OR HINES WHOLESALE NURSERY / MONROVIA NURSERY COMPANY QUALITY OR EQUAL. THE OWNER'S SUPERINTENDENT WILL REVIEW ALL PLANT MATERIAL WHEN SPOTTED FOR PLANTING AND WILL NOT HESITATE TO REJECT ANY MATERIAL OF QUESTIONABLE QUALITY, OR OF LESS THAN THE LARGEST REASONABLE SIZE MATERIAL AVAILABLE.
- NO PLANT SUBSTITUTIONS ARE TO BE MADE WITHOUT THE WRITTEN CONSENT OF THE LANDSCAPE ARCHITECT.
- ALL GROUND COVER AS NOTED IN THE LEGEND SHALL BE PLANTED IN STAGGERED ROWS CONTINUOUSLY UNDER ALL TREES AND SHRUBS IN THE AREAS AS DESIGNATED ON THE PLANS AND AT THE SPACING INDICATED IN THE LEGEND. GROUND COVER SHALL BE INSTALLED NO CLOSER THAN 1/2 THE ON CENTER SPACING AS INDICATED ON THE PLANS.
- CONTRACTOR SHALL PROVIDE AN AUTOMATIC IRRIGATION SYSTEM TO ALL LANDSCAPE AREAS. DRIP IRRIGATION SHALL BE USED IN GRAVEL AND COBBLE AREAS. SPRAY IRRIGATION SHALL BE USED FOR LAWN AREAS.
- WARNING: PLANT MATERIAL LISTED MAY OR MAY NOT HAVE BEEN APPROVED BY THE AGRICULTURAL COMMISSIONER'S OFFICE. LANDSCAPE CONTRACTOR, PLEASE CONTACT THE OWNER'S REPRESENTATIVE FOR STATUS OF AGRICULTURAL COMMISSIONER'S APPROVAL OR DENIAL. PLANT MATERIAL NOT CONFORMING WITH QUARANTINE LAW MAY BE DESTROYED AND CIVIL ACTION TAKEN. ALL PLANT MATERIAL IS SUBJECT TO INSPECTION AT THE DISCRETION OF THE AGRICULTURAL COMMISSIONER'S OFFICE. ALL PLANT MATERIAL MUST BE FREE FROM RED SCALE (ACONIDIELLA AURANTI).
- LANDSCAPE ARCHITECT CANNOT ASSUME RESPONSIBILITY FOR ANY PLANT MATERIAL UTILIZED ON SITE WHICH ARE NOT SHOWN ON THE PLANS AND/OR HAVE NOT BEEN APPROVED BY THE AGRICULTURAL COMMISSIONER'S OFFICE.
- CONTRACTOR IS RESPONSIBLE FOR FINAL QUANTITIES AS ILLUSTRATED ON THE PLANTING PLANS. QUANTITIES IN THE LEGEND MAY NOT BE ACCURATE.
- CONTRACTOR TO PROVIDE BID FOR THE MAINTENANCE. MAINTENANCE PERIOD SHALL LAST NINETY (90) DAYS AFTER NOTIFICATION FROM THE LANDSCAPE ARCHITECT OF A SUCCESSFUL FINAL WALK THROUGH AND WILL BEGIN ONCE ALL ITEMS ON THE FINAL WALK THROUGH PUNCH LIST HAVE BEEN SATISFACTORILY ADDRESSED BY A WRITTEN STATEMENT INDICATING SUCH FROM THE LANDSCAPE ARCHITECT TO THE OWNER.
- CONTRACTOR SHALL REPLACE PLANTS WHICH ARE FOUND IN AN UNHEALTHY OR IMPAIRED CONDITION, MISSING OR DEAD DURING THE MAINTENANCE PERIOD. TREES SHALL BE GUARANTEED FOR ONE YEAR AND SHRUBS SHALL BE GUARANTEED FOR 90 DAYS FROM DATE OF FINAL ACCEPTANCE.
- THE CONTRACTOR SHALL REFER TO SOIL RESULTS BY WAYPOINT ANALYTICAL T14-282-8111. CONTRACTOR SHALL AMEND SOIL, PREPARE BACKFILL AND FERTILIZE PER RESULTS. WHOLESALE COST OF MATERIALS ONLY SHOULD TEST RESULTS REQUIRE ADDITIONAL MATERIALS.
- TURF TO BE TIFWAY HYBRID BERMUDA 419' BERMUDA HYBRID SOD. TO BE OVERSEEDDED WITH RYE IF PLANTED IN THE WINTER SEASON COMMENCING IN OCTOBER-MAY.
- ALL TURF AREAS SHALL BE GRADED TO FINISH GRADE ALLOWING FOR AMENDMENTS. THEN INCORPORATE THE AMENDMENTS ACCORDING TO THE SOILS REPORT ON SHEET L2.3.

- ### PREPARATION OF UNAMENDED, ON-SITE SOIL BEFORE AMENDING
- EXCAVATION: EXCAVATE SOIL FROM DESIGNATED AREA(S) AND STOCKPILE UNTIL AMENDED.
 - UNACCEPTABLE MATERIALS: CLEAN SOIL OF CONCRETE SLURRY, CONCRETE LAYERS OR CHUNKS, CEMENT, PLASTER, BUILDING DEBRIS, OILS, GASOLINE, DIESEL FUEL, PAINT THINNER, TURPENTINE, TAR, ROOFING COMPOUND, ACID, AND OTHER EXTRANEOUS MATERIALS THAT ARE HARMFUL TO PLANT GROWTH.
 - UNSUITABLE MATERIALS: CLEAN SOIL TO CONTAIN A MAXIMUM OF 10% BY DRY WEIGHT OF STONES, ROOTS, PLANTS, SOD, CLAY LUMPS, AND POCKETS OF COARSE SAND.
 - SCREENING: PASS UNAMENDED SOIL THROUGH A 2" SIEVE TO REMOVE LARGE MATERIALS.

- ### BLENDING PLANTING SOIL IN PLACE
- MIX AMENDMENTS WITH IN-PLACE, UNAMENDED SOIL TO PRODUCE REQUIRED PLANTING SOIL. DO NOT APPLY MATERIALS OR TILL IF EXISTING SOIL OR SUBGRADE IS FROZEN, MUDDY, OR EXCESSIVELY WET.
 - PREPARATION: TILL UNAMENDED, EXISTING SOIL IN PLANTING AREAS TO A MINIMUM DEPTH OF 8 INCHES, REMOVE STONES LARGER THAN 2 INCHES IN ANY DIMENSION AND STICKS, ROOTS, RUBBISH, AND OTHER EXTRANEOUS MATTER AND LEGALLY DISPOSE OF THEM OFF OWNER'S PROPERTY.
 - MIXING: APPLY SOIL AMENDMENTS AND FERTILIZER, IF REQUIRED, EVENLY ON SURFACE, AND THOROUGHLY BLEND THEM INTO FULL DEPTH OF UNAMENDED, IN-PLACE SOIL TO PRODUCE PLANTING SOIL.
 - COMPACTION: COMPACT BLENDED PLANTING SOIL TO 85% PERCENT OF MAXIMUM STANDARD PROCTOR DENSITY ACCORDING TO ASTM D 698 EXCEPT WHERE A DIFFERENT COMPACTION VALUE IS INDICATED ON DRAWINGS.
 - FINISH GRADING: GRADE PLANTING SOIL TO A SMOOTH, UNIFORM SURFACE PLANE WITH LOOSE, UNIFORMLY FINE TEXTURE. ROLL AND RAKE, REMOVE RIDGES, AND FILL DEPRESSIONS TO MEET FINISH GRADE.

- ### MAINTENANCE
- ADHERENCE TO SPECIFICATIONS
 - CONTRACTOR SHALL ADHERE TO THE FOLLOWING MAINTENANCE SPECIFICATIONS DURING THE ESTABLISHED MAINTENANCE PERIOD.
 - SCOPE OF MAINTENANCE WORK
 - PLANT MAINTENANCE WORK SHALL CONSIST OF APPLICATION FOR WATER, WEEDING, CARING FOR, EDGING AND MOWING OF LAWNS AND PERFORMING THE FOLLOWING FINAL PLANT ESTABLISHMENT WORK. PLANTING AREAS SHALL TO BE RAKED OF ALL LEAVES/DEBRIS.
 - THE ENTIRE PROJECT IS TO BE MAINTAINED FOR A PERIOD OF APPROXIMATELY 90 CALENDAR DAYS, COMMENCING FROM THE TIME OWNER'S AUTHORIZED REPRESENTATIVE AND OWNER'S AUTHORIZED REPRESENTATIVE WALKS PRELIMINARY WALK.
 - DURING THE FINAL MAINTENANCE PERIOD, ALL PLANTS AND PLANTED AREAS SHALL BE KEPT WELL WATERED AND WEED FREE AT ALL TIMES. WEEDS, DALLAS & JOHNSON GRASS AND BERMUDA GRASS SHALL BE REMOVED.
 - APPROXIMATELY 30 TO 45 DAYS AFTER INITIAL PLANTING, APPLY A SLOW RELEASE BALANCED FERTILIZER TO BOTH THE TURF AND SHRUB AREA AT A RATE OF 1/2 LBS. OF NITROGEN PER 1000 S.F.
 - CONTRACTOR SHALL BE RESPONSIBLE FOR DISEASE AND PEST/VERMIN CONTROL DURING THE MAINTENANCE PERIOD AND A RECORD OF PESTICIDES USED SHALL BE FURNISHED TO OWNER'S AUTHORIZED REPRESENTATIVE.
 - CONTRACTOR SHALL RAISE OR LOWER SPRINKLER HEADS TO PROPER LEVEL AND SHALL ADJUST HEADS AS NEEDED FOR FULL COVERAGE.
 - IN CASE OF NEGLIGENT OR IMPROPER MAINTENANCE, THE LANDSCAPE ARCHITECT SHALL STATE IN WRITING TO THE CONTRACTOR HIS OBSERVATIONS AND RECOMMENDATIONS. ANY CLAIM NOT IN WRITING SHALL NOT BE CONSIDERED.
 - ALL PLANTS THAT SHOW SIGN OF FAILURE TO GROW AT ANY TIME DURING THE LIFE OF THE CONTRACT, INCLUDING THE MAINTENANCE PERIOD, OR THOSE PLANTS SO INJURED OR DAMAGED AS TO RENDER THEM UNSUITABLE FOR THE PURPOSE INTENDED, SHALL BE REPLACED IN KIND WITHIN TEN (10) DAYS OF WRITTEN NOTIFICATION, AT THE EXPENSE OF THE CONTRACTOR.

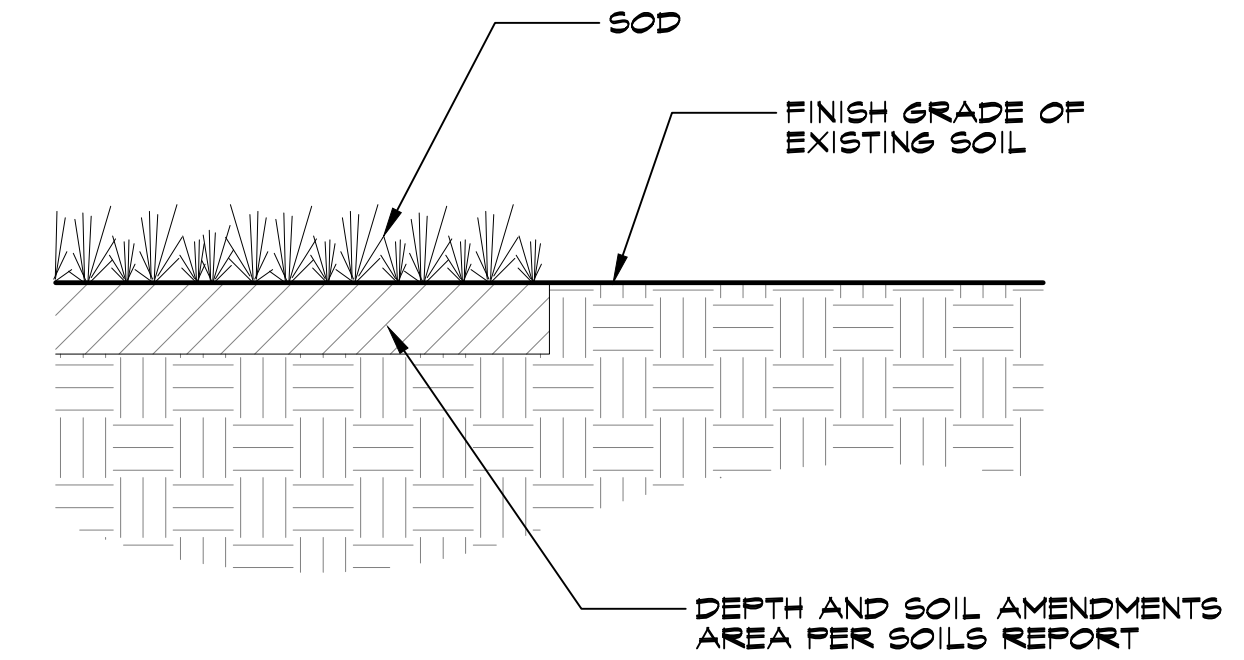

A SOD EDGE

NO PERMANENT STRUCTURES OR TREES WITHIN CVOID AND/OR EASEMENTS. CVOID WILL NOT BE RESPONSIBLE FOR DAMAGE OR REPLACEMENT OF ANY SURFACE IMPROVEMENTS, INCLUDING BUT NOT LIMITED TO, DECORATIVE CONCRETE, LANDSCAPING, CURBS, GUTTER, SIDEWALKS, PLANTERS, GATES AND RELATED IMPROVEMENTS INSTALLED WITHIN THE CVOID AND/OR USER.

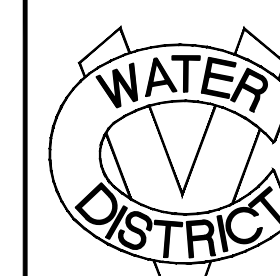

THESE PLANS HAVE BEEN REVIEWED BY THE COACHELLA VALLEY WATER DISTRICT IN ACCORDANCE WITH CALIFORNIA GOVERNMENT CODE, SECTION 65951 ET SEQ. REQUIRING EFFICIENT LANDSCAPE AND IRRIGATION DESIGN IN COOPERATION WITH THE LOCAL GOVERNING AGENCY (CITY AND COUNTY).

APPROVAL OF THIS DRAWING BY CVOID STAFF DOES NOT CONSTITUTE APPROVAL TO ENCRUCH INTO DISTRICT AND USER RIGHT OF WAY. TREES, PLANTS, WALLS AND PERMANENT STRUCTURE OF ANY KIND MAY NOT BE PLANTED OR INSTALLED IN CVOID AND USER EASEMENTS OR RIGHT-OF-WAY WITHOUT FIRST OBTAINING AN ENCROACHMENT PERMIT FROM CVOID.

DATE _____ WATER MANAGEMENT DEPARTMENT _____

CVOID PLAN NO. _____ DEVELOPMENT SERVICES DEPARTMENT _____



HERMANN DESIGN GROUP
77-899 WOLF RD.
SUITE 102
PALM DESERT, CA 92211
LIC# 2754 EXP. 04/30/24
PH. (760) 777-9131
FAX (760) 777-9132

OWNER:
SALTON COMMUNITY SERVICES DISTRICT
1209 VAN BUREN AVENUE
THERMAL, CA 92274
OFFICE (760) 394-4446

PROJECT:
DESERT SHORES SOCCER PARK
001-155-001
THERMAL CA, 92274

REVISIONS	DATE	BY



SHEET TITLE
PLANTING DETAILS

DESIGNED JE
DRAWN CD
CHECKED CH
DATE 6/20/23
SCALE N.T.S.
JOB NO. 2301B

SHEET
L2.2
OF 9 SHEETS

© Hermann Design Group. All rights reserved. No part of this document may be reproduced, stored in a retrieval system, or transmitted in any form or by any means, electronic, mechanical, photocopying, recording, or by any information storage and retrieval system, without the prior written permission of Hermann Design Group.

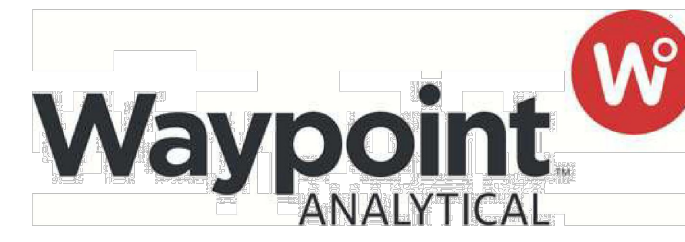

Anaheim Office
Lab No: 23-109-0019
April 26, 2023

Hermann Design Group, Inc.
77-899 Wolf Rd., STE. # 102
Palm Desert, CA 92211

Attn: Jose Estrada

Project: Desert Shores Park

Attached are the results of the analysis performed on a soil sample that was collected from the above mentioned project site from a depth of 12 inches by the client and received by our laboratory on April 19, 2023. Organic fertilizer and amendment recommendations were requested. This sample was analyzed for nutrient levels, agricultural suitability, and physical characteristics in preparation for new landscape installation.

Analytical Results and Comments

The reaction of the soil is slightly alkaline at 7.5 on the pH scale with a high level of free lime present. These levels could cause plants that are sensitive to alkalinity to show yellowing of foliage beginning with the younger growth. A high level of free lime is present indicating that the pH is strongly buffered in the alkaline range. Incorporation of soil sulfur to a depth of 6 inches may adjust the pH downward toward the preferred near neutral range to the depth of incorporation. That change would happen slowly and plants that are sensitive to alkalinity should be avoided.

Salinity (ECe) is high at 16.2 dS/m and is largely due to an abundance of soluble sodium (188 meq/L). These salt levels far exceed the tolerance threshold of most ornamental plant material. Very salt tolerant turf species such as seashore paspalum could potentially tolerate these salt levels if well established and the grass is not stressed by other factors such as heavy traffic, compaction, over watering, under watering, soil compaction, pest infestation, disease, or low light conditions. If the grass is stressed by other factors, then even salt tolerant species could become less tolerant of elevated salts. The salt levels will restrict the use of all but salt tolerant ornamental trees and shrubs as well. The sodium present is very poorly balanced by other cations as indicated by the high sodium adsorption ratio (SAR) of 39. This sodium imbalance is expected to adversely affect soil structure and water infiltration.

Boron is elevated at 3.23 parts per million (ppm), which could cause a broad range of trees and shrubs to show tip and edge burning of older leaves and plants that are not tolerant of elevated levels of boron in the soil are expected to perform poorly. Common turfgrass species should tolerate this amount of boron in the soil.

In terms of fertility, phosphorus is very low and magnesium is moderately low. In the minor element category, copper, manganese, and iron are low while zinc is moderately low.

The texture of the sample is 'sandy loam' based on the USDA soil classification standards. The estimated water infiltration rate is a moderate 0.28 inch per hour. The infiltration rates may vary with the degree of soil compaction throughout the site. Organic content is low at 0.81% on a dry weight basis.

4741 East Hunter Ave., Ste. A Anaheim CA 92807
(714) 282-8777 (714) 282-8575 fax
www.waypointanalytical.com

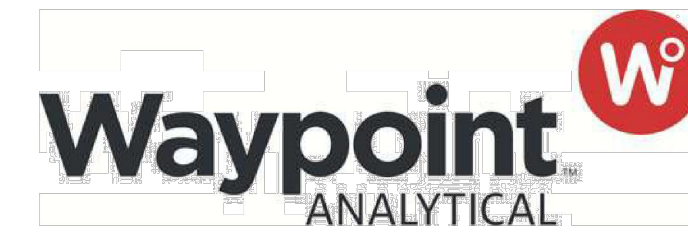

Page 2
Hermann Design Group, Inc.
April 26, 2023

Comments and Recommendations

Reclamation is required prior to planting in order to reduce the soluble salts in the root zone to a safer range. Leaching should also reduce the boron to a degree but removal of boron by leaching is about three times as difficult as for other salts. We recommend the first several irrigations should be especially thorough to try to accomplish some leaching prior to planting. Proper plant selection will be an important factor in establishing a successful landscape. Use plants tolerant of these conditions. If drainage is impeded by compaction or other underlying factor, the areas may require deep ripping in order to improve drainage and allow for the leaching of salts past the root zone. The organic amendment, sulfur, and bone meal should be incorporated prior to leaching.

We estimate that approximately 7 inches of good quality water low in soluble salts and boron needs to move through the soil in order to reduce the salinity to a safe level of 3.5 dS/m in the surface 12 inches of soil. Keep in mind that as salts and boron are flushed out of the root zone, salinity and boron in the subsoil will likely remain elevated.

Be sure to apply leaching irrigations in a manner that avoids run-off and pooling. The soil should be allowed to dry slightly between irrigations to avoid creating anaerobic soil conditions and/or an environment that favors root diseases. As mentioned above, drainage must be sufficient for leaching to be effective.

Gypsum (calcium sulfate) application is often recommended for downward SAR adjustment. However, in this case the soluble calcium and sulfate numbers are high, indicating an abundance of gypsum already in the soil. Due to the limited solubility of gypsum, it is not likely that an addition of that material would provide much benefit at this point. It is also worth noting that when a sodium imbalance issue is accompanied by a very high salinity value, as in this case, water infiltration is often good in spite of the elevated SAR. As leaching irrigations flush calcium and magnesium out of the root zone, along with sodium, water infiltration may become impeded. If this happens, gypsum application may be warranted at that time and the material should be uniformly broadcast at a rate of 25 lbs. per 1000 sq. ft. followed by additional leaching.

Once leaching is complete, it is recommended to submit additional samples to check post-leaching salinity and SAR values (Waypoint Analytical Testing Procedure A02). Additional leaching and/or gypsum application may be necessary at that time.

4741 East Hunter Ave., Ste. A Anaheim CA 92807
(714) 282-8777 (714) 282-8575 fax
www.waypointanalytical.com

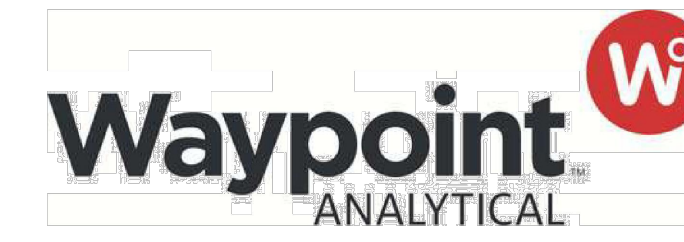

Page 3
Hermann Design Group, Inc.
April 26, 2023

Recommendations

Surface Soil Preparation for Turf and Mass Planting Areas

If feasible, prior to amending the areas where severe compaction exists, the surface soil should be ripped or tilled to a 9-inch depth. Uniformly broadcast and blend the following with existing soil to a 6-inch depth. 12-0-0 fertilizer should be raked or scratched into the surface 3-4 inches after leaching. Since soil salinity is high, a non-saline organic amendment should be selected.

Materials	Amount per 1000 sq. ft.
Nitrogen fortified organic amendment (compost* or redwood or fir sawdust)	3 cu. yards
Soil Sulfur	12 lbs.
Feather Meal (12-0-0)	10 lbs.
Bone Meal (3-15-0)	25 lbs.

*Rates and fertilizers may have to be adjusted depending on analysis of selected compost.

Tree and Shrub Planting Guidelines for General Ornamentals

- Excavate planting pits at least twice the diameter of the rootball.
- The top of the rootball should be at or slightly above final grade.
- To improve soil chemistry, uniformly blend 1 lb. of iron sulfate per cubic yard of backfill soil. Handle iron sulfate with caution since it will severely stain moist concrete. Iron sulfate is not organic but it is often acceptable for use if warranted.
- To improve soil fertility, uniformly blend 1.3 lbs. of bone meal (3-15-0) and 0.5 lb. of feather meal (12-0-0) per cubic yard of backfill. Limit the fertilizers to the upper 12 inches of backfill only.
- Organic material is not required in the backfill; however, if you wish, the amended surface soil or a soil blend consisting of no more than 20% by volume organic matter can be placed in the upper 12 inches of backfill only. Soil below this depth should not contain any added organic matter because of the threat of plant disease and/or anaerobic soil conditions developing.
- Do not cover the original rootball with other soil. Ideally, a temporary soil berm is often constructed around the outer edge of the rootball to help channel water into the rootball and then into surrounding soil until roots are established in the backfill and the rootball is no longer the sole source of water for the plant.
- Ideally, a weed and turf free zone, preferably 2-3 ft. in diameter, should be maintained just beyond the diameter of the planting hole. A 2-4 inch deep layer of coarse mulch can be placed around the tree or shrub; mulch should be kept a minimum 4-6 inches from the trunk.

4741 East Hunter Ave., Ste. A Anaheim CA 92807
(714) 282-8777 (714) 282-8575 fax
www.waypointanalytical.com

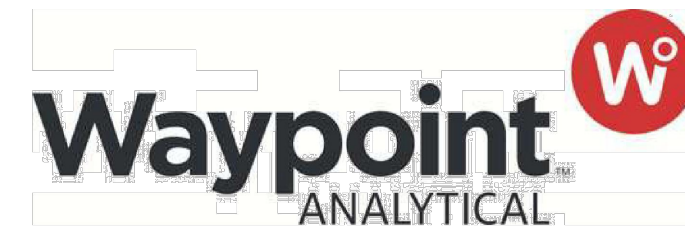

Page 4
Hermann Design Group, Inc.
April 26, 2023

Maintenance fertilization may rely primarily on a nitrogen only program supplemented with a complete fertilizer in the fall and spring. Blood Meal (12-0-0) provides available nitrogen fairly rapidly while materials such as Feather Meal (12-0-0), Soybean or Cotton Seed Meal (7-1-1) are slower to provide available nitrogen, but they extend the length of time they make this contribution. In order to provide a good supply of nitrogen for a 3-4 month time frame a good combination would be 6 pounds Blood Meal and 14 pounds Feather Meal per 1000 sq. ft. The first application should be approximately 60-90 days after planting or at the first mowing in turf areas. The long term maintenance program should consider spring and fall applications of an organic fertilizer blend such as Nature Safe 8-5-5 that would also supplement phosphorus and potassium nutrition to a greater extent.

As noted above, some of the micronutrients are below optimum. When these nutrients are low, especially in an alkaline soil, deficiencies can sometimes show in the plants. If deficiencies show once plants have become established, they may be addressed upon the first sign of deficiency. Symptoms of manganese deficiency may be seen as a general loss of color in the young leaves, followed by yellowing between veins and brownish-black spots appearing. Iron and zinc deficiency symptoms are often characterized by yellow, almost white, interveinal chlorosis on the youngest growth. If these symptoms are apparent once plants are established, then application of iron, zinc, and/or manganese chelate at the manufacturer's label rate may improve appearance. Many of the chelated micronutrient products on the market are not organic materials but are often more effective on alkaline soils than some of the other forms of trace elements. Chelated micronutrients are generally accepted fertilizers in organic production as long as there is a need for zinc, manganese, and iron demonstrated by testing. Decreasing the soil pH to a more favorable range would also help improve micronutrient availability.

If we can be of any further assistance, please feel free to contact us.

Joe Kiefer, CCA

4741 East Hunter Ave., Ste. A Anaheim CA 92807
(714) 282-8777 (714) 282-8575 fax
www.waypointanalytical.com



Hermann Design Group, Inc.
77-899 Wolf Rd. Suite 102
Palm Desert CA 92211

4741 East Hunter Ave. Suite A
Anaheim, CA 92807
Main 714-282-8777 Fax 714-282-8575
www.waypointanalytical.com

Project : Desert Shores Park

Report No : 23-109-0019
Purchase Order :
Date Recd : 04/19/2023
Date Printed : 04/25/2023
Page : 1 of 1

COMPREHENSIVE SOIL ANALYSIS

Sample Description - Sample ID	Half Sat %	pH	ECe dS/m	NO ₃ -N	NH ₄ -N	PO ₄ -P	K	Ca	Mg	Cu	Zn	Mn	Fe	Organic % dry wt.	Lab No.
	TEC	Qual Lime		ppm	ppm	ppm	ppm	ppm	ppm	ppm	ppm	ppm	ppm		
Site Soil	17	7.5	16.2	33	6	2	213	1230	122	0.4	2.6	1	2	0.81	42892
	99	High		1.1	0.1	1.6	0.8	0.6	0.3	0.5	0.1	0			

Saturation Extract Values						SAR	Gravel %		Percent of Sample Passing 2 mm Screen					USDA Soil Classification	Lab No.
Ca meq/L	Mg meq/L	Na meq/L	K meq/L	B ppm	SO ₄ meq/L		Coarse 5-12	Fine 2-5	Very Coarse 1-2	Coarse 0.5-1	Med. to Very Fine 0.05-0.5	Silt .002-.05	Clay 0-.002		
32	12.8	188	3.2	3.23	87	39.7	0.2	2.7	24.8	21.8	31.5	11.4	10.4	Sandy Loam	42892

Sufficiency factor (1.0=sufficient for average crop) below each nutrient value. N factor based on 200 ppm constant feed. SAR = Sodium adsorption ratio. Half Saturation %—approx field moisture capacity. Nitrogen(N), Potassium(K), Calcium(Ca) and Magnesium(Mg) by sodium chloride extraction. Phosphorus(P) by sodium bicarbonate extraction. Copper(Cu), Zinc(Zn), Manganese(Mn) and Iron(Fe) by DTPA extraction. Sat. ext. method for salinity (ECe as dS/m), Boron (B), Sulfate(SO₄), Sodium(Na). Gravel fraction expressed as percent by weight of oven-dried sample passing a 12mm(1/2 inch) sieve. Particle sizes in millimeters. Organic percentage determined by Walkley-Black or Loss on Ignition.

LOW = SUFFICIENT = HIGH



HERMANN DESIGN GROUP
77-899 WOLF RD.
SUITE 102
PALM DESERT, CA
92211

LIC# 2754 EXP. 04/30/24
PH. (760) 777-9131
FAX (760) 777-9132

PROJECT: SALTON COMMUNITY SERVICES DISTRICT
1209 VAN BUREN AVENUE
THERMAL, CA 92274
OFFICE (760) 384-4446

DESERT SHORES SOCCER PARK
001-155-001
THERMAL CA, 92274

REVISIONS	DATE	BY

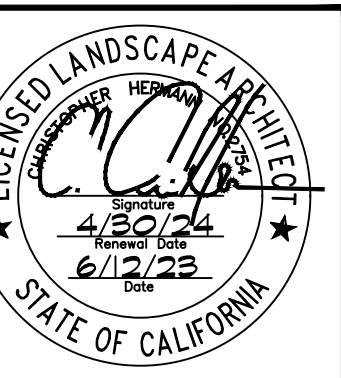

SHEET TITLE
SOILS REPORT

DESIGNED	JE
DRAWN	CD
CHECKED	CH
DATE	6/20/23
SCALE	N.T.S.
JOB NO.	23013

SHEET
L2.3
OF 9 SHEETS

NO PERMANENT STRUCTURES OR TREES WITHIN CIVID AND/OR EASEMENTS. CIVID WILL NOT BE RESPONSIBLE FOR DAMAGE OR REPLACEMENT OF ANY SURFACE IMPROVEMENTS, INCLUDING BUT NOT LIMITED TO, DECORATIVE CONCRETE, LANDSCAPING, CURB, GUTTER, SIDEWALKS, PLANTERS, GATES AND RELATED IMPROVEMENTS INSTALLED WITHIN THE CIVID AND/OR USER.

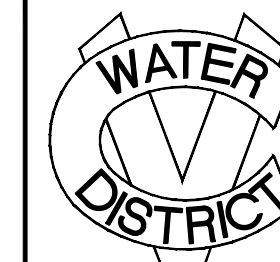

THESE PLANS HAVE BEEN REVIEWED BY THE COACHELLA VALLEY WATER DISTRICT IN ACCORDANCE WITH CALIFORNIA GOVERNMENT CODE, SECTION 65981 ET SEQ. REQUIRING EFFICIENT LANDSCAPE AND IRRIGATION DESIGN IN COOPERATION WITH THE LOCAL GOVERNING AGENCY (CITY AND COUNTY).

APPROVAL OF THIS DRAWING BY CIVID STAFF DOES NOT CONSTITUTE APPROVAL TO ENCRUCH INTO DISTRICT AND USER RIGHT OF WAY. TREES, PLANTS, WALLS AND PERMANENT STRUCTURE OF ANY KIND MAY NOT BE PLANTED OR INSTALLED IN CIVID AND USER EASEMENTS OR RIGHT-OF-WAY WITHOUT FIRST OBTAINING AN ENCROACHMENT PERMIT FROM CIVID.

DATE _____ WATER MANAGEMENT DEPARTMENT _____
CIVID PLAN NO. _____ DEVELOPMENT SERVICES DEPARTMENT _____

EXHIBIT B

SAMPLE AGREEMENT FOR SERVICE

**IMPERIAL COUNTY
DESERT SHORES SOCCER PARK
PHASE 1**

COUNTY PROJECT NO. SR53009

1 **AGREEMENT FOR CONSTRUCTION SERVICES**

2 **«Contractor_Business_Name»**

3 THIS AGREEMENT FOR CONSTRUCTION SERVICES (“Agreement”), made and entered
4 into effective the ____ day of _____, 2023, by and between the COUNTY OF IMPERIAL, a
5 political subdivision of the State of California, through its Department of Public Works (“COUNTY”)
6 and «Contractor_Business_Name», a «Contractor_Business_Type» licensed to do business within
7 the state of California (“CONTRACTOR”) (individually, “Party;” collectively, “Parties”) shall be as
8 follows:

9 **RECITALS**

10 **WHEREAS**, COUNTY desires to retain a qualified individual, firm or business entity to
11 provide professional construction services for Imperial County Project Number «Project_Number»,
12 «Project_Name» (“Project”); and

13 **WHEREAS**, COUNTY wishes to engage CONTRACTOR for performance of such services as
14 are provided for herein and CONTRACTOR is willing to accept such engagement.

15 **NOW, THEREFORE**, COUNTY and CONTRACTOR have and hereby agree to the
16 following:

17 **1. DEFINITIONS.**

18 **1.1.** “Invitation for Bid” shall mean the document entitled, “«Name_of_RFP»,” dated
19 «Date_of_RFP», which includes all special notices, addendums, exhibits and Plans and
20 Specifications as defined in Paragraph 1.3. The Invitation for Bid is attached hereto as
21 **Exhibit “A”** and incorporated herein as though fully set forth.

22 **1.2.** “Proposal” shall mean CONTRACTOR’s document entitled “«Name_of_Proposal»,”
23 dated «Date_of_Proposal» and submitted to the Clerk of the Board. The Proposal is
24 attached hereto as **Exhibit “B”** and incorporated herein as though fully set forth.

25 **1.3.** “Plans and Specifications” shall mean the plans and specifications approved by the
26 Director of Public Works, or his/her designee, for Project Number «Project_Number».
27 While COUNTY is responsible for the completeness and accuracy of the Plans and
28 Specifications for the Project, CONTRACTOR is required to review the Plans and

1 Specifications and promptly report any errors or omissions to COUNTY.

2 **2. CONTRACT COORDINATION.**

3 **2.1.** The Director of Public Works or his/her designee shall be the representative of
4 COUNTY for all purposes under this Agreement. The Director of Public Works or
5 his/her designee is hereby designated as the Contract Manager for COUNTY. He/she
6 shall supervise the progress and execution of this Agreement.

7 **2.2.** CONTRACTOR shall assign a single Contract Manager to have overall responsibility
8 for the progress and execution of this Agreement. Should circumstances or conditions
9 subsequent to the execution of this Agreement require a substitute Contract Manager for
10 any reason, the Contract Manager designee shall be subject to the prior written
11 acceptance and approval of COUNTY's Contract Manager.

12 **3. SCOPE OF WORK TO BE PERFORMED BY CONTRACTOR.**

13 **3.1.** CONTRACTOR shall furnish all work, labor, tools, equipment, materials, supervision,
14 scheduling, coordination and contract administration necessary to construct and
15 complete the Project in a good, expeditious, workman-like and substantial manner
16 under the terms of and in full and complete compliance with this Agreement ("Work").

17 **3.2.** CONTRACTOR shall comply with and perform work consistent with all terms,
18 conditions and requirements of the Plans, Specifications, the Invitation for Bids and this
19 Agreement.

20 **3.3.** All described work shall be constructed, installed, placed and performed in
21 conformance with the Plans and Specifications and all Special Provisions contained
22 therein and as directed by COUNTY's engineer.

23 **3.4.** In the event of a conflict among this Agreement, the Invitation for Bid and the Proposal,
24 the Invitation for Bid shall take precedence over the Proposal and this Agreement shall
25 take precedence over both.

26 **3.5.** CONTRACTOR shall perform such other tasks as necessary and proper for the full
27 performance of the obligations assumed by CONTRACTOR hereunder; including but
28 not limited to any additional work or change orders agreed upon pursuant to written

1 authorization as described in Section 5. Proposed additional work or change order
2 requests, when applicable, will be attached and incorporated herein under **Exhibit “B”**
3 (as “B-1,” “B-2,” etc.).

4 **4. TRENCHING REQUIREMENTS AND UTILITY RELOCATION.**

5 **4.1. Four Feet (4’) Below the Surface.** In the event the Project involves digging trenches or
6 other excavations that extend deeper than four feet (4’) below the surface,
7 CONTRACTOR shall:

8 **4.1.1.** Promptly, and before the following conditions are disturbed, notify COUNTY,
9 in writing, of any:

10 (a) Material that CONTRACTOR believes may be material that is hazardous
11 waste, as defined in Health & Safety Code §25117, that is required to be
12 removed to a Class I, Class II or Class III disposal site in accordance
13 with provisions of existing law;

14 (b) Subsurface or latent physical conditions at the site differing from those
15 indicated by information about the site made available to bidders prior to
16 the deadline for submitting bids; and

17 (c) Unknown physical conditions at the site of any unusual nature, different
18 materially from those ordinarily encountered and generally recognized as
19 inherent in work of the character provided for in the Agreement.

20 **4.1.2.** In response to any written notice generated pursuant to Subparagraph 4.1.1,
21 COUNTY shall promptly investigate the conditions, and if it finds that the
22 conditions do materially so differ, or do involve hazardous waste, and cause a
23 decrease or increase in CONTRACTOR’s cost of, or the time required for,
24 performance of any part of the Work, COUNTY shall issue a change order
25 under the procedures described in this Agreement.

26 **4.1.3.** In the event that a dispute arises between COUNTY and CONTRACTOR
27 whether the conditions materially differ, or involve hazardous waste, or cause a
28 decrease or increase in CONTRACTOR’s cost of, or time required for,

1 performance of any part of the Work, CONTRACTOR shall not be excused
2 from any scheduled completion date provided for by this Agreement, but shall
3 proceed with all Work to be performed under this Agreement. CONTRACTOR
4 shall retain any and all rights provided either by contract or by law which pertain
5 to the resolution of disputes and protests between the Parties.

6 **4.2. Trenching Requirements – Project in Excess of Twenty-Five Thousand Dollars**
7 **(\$25,000) and Five Feet (5') Below the Surface.** For projects involving both an
8 estimated expenditure in excess of twenty-five thousand dollars (\$25,000) and the
9 excavation of any trench five feet (5') or more in depth, CONTRACTOR shall submit a
10 detailed plan showing the design of shoring, bracing, sloping or other provisions to be
11 made for worker protection from the hazard of caving ground during the excavation of
12 such trench. The plan must be accepted by COUNTY (or by a registered civil or
13 structural engineer, employed by COUNTY, to whom authority to accept has been
14 delegated) in advance of excavation. If such plan varies from the shoring system
15 standards, the plan shall be prepared by a registered civil or structural engineer.
16 Nothing in this Paragraph shall allow CONTRACTOR to use a shoring, sloping, or
17 protective system less effective than that required by California Construction Safety
18 Orders. Further, nothing in this Paragraph shall be construed to impose tort liability on
19 COUNTY or any of its employees.

20 **4.3. Utilities Relocation.** In the event that CONTRACTOR, in the scope of work,
21 encounters utilities not shown on COUNTY'S plans, COUNTY shall compensate
22 CONTRACTOR for utilities relocation work. COUNTY shall also waive liquidated
23 damages for any delay that occurs as a result of said encounter and/or relocation of
24 utilities.

25 **5. CHANGE ORDERS.**

26 **5.1. Change Orders.** CONTRACTOR shall make no changes to the Work to be performed
27 pursuant to this Agreement, including but not limited to additions, deletions,
28 modifications or substitutions, nor shall CONTRACTOR perform any extra work

1 (collectively, “Change Order Work”) without the prior written consent of COUNTY. If
2 CONTRACTOR encounters conditions it considers different from those described in
3 **Exhibit “A”** to this Agreement, CONTRACTOR may request a change order in
4 conformance with COUNTY’s standard procedure (“Change Order”). If COUNTY
5 approves the request, CONTRACTOR will execute a Change Order and
6 CONTRACTOR’s execution of the Change Order shall confirm approval thereof.
7 COUNTY may order additional work, and CONTRACTOR shall perform such changes
8 in the Work as directed by COUNTY in any Change Order prepared by
9 CONTRACTOR. COUNTY’s rights to eliminate portions of the Work or to initiate a
10 Change Order shall not be limited in any way. The Change Order shall be in writing
11 and shall include:

12 **5.1.1.** Any and all supporting documents and drawings depicting the source and
13 location of the desired change, and explain in detail the field conditions and
14 reasons for the requested change;

15 **5.1.2.** Any change or adjustment to the compensation set forth in this Agreement as a
16 result of changes in the Work based on a lump sum or time and material basis,
17 as may be directed by COUNTY; and

18 **5.1.3.** Any request for adjustments to time for completion of the Project.

19 **5.2.** Payment for Change Order Work. CONTRACTOR shall not be entitled to receive any
20 compensation for work, labor, materials or changes of any kind, regardless of whether
21 ordered by COUNTY or any of its representatives, unless a Change Order has been
22 submitted in writing and approved prior to the commencement of any Change Order
23 Work as described above. If the changes are required by any inspecting governmental
24 agencies or utility companies, or are otherwise required to comply with any codes, laws,
25 rules or regulations, including those set forth in this Agreement, then CONTRACTOR
26 shall not be entitled to any increases in the compensation set forth in this Agreement or
27 other compensation as a result of the changes.

28 **5.3.** Disputed Change Order Work. Any dispute concerning the performance of such

1 Change Order Work or the amount of compensation to be paid to CONTRACTOR by
2 COUNTY shall not affect CONTRACTOR's obligation to perform such Change Order
3 Work. CONTRACTOR agrees that it shall timely complete all Change Order Work
4 even if there shall be a dispute between CONTRACTOR and COUNTY over the
5 amount or scope of the Change Order Work. CONTRACTOR shall have the right to be
6 compensated for any undisputed Change Order Work amounts as determined to be
7 undisputed in COUNTY's sole discretion.

8 **5.4. Authorized Representative.** No Change Order shall be valid or binding against
9 COUNTY unless such Change Order has been executed by COUNTY's designated
10 representative, who is the Director of Public Works. COUNTY shall notify
11 CONTRACTOR in writing if the designated representative is changed.

12 **5.5. Limits.** When applicable, the authority to execute a Change Order on this Project shall
13 not exceed the amount allowed by law pursuant to Public Contract Code sections
14 20137-20142 et seq. Where Change Orders are in an amount between ten percent
15 (10%) and twenty-five percent (25%) of the amount set forth in this Agreement and
16 based on a need for additional quantities due to an increase in the unit quantities
17 required to complete the project in excess of the COUNTY's Engineer's estimate of
18 unit quantities as set forth in the Invitation to Bid, CONTRACTOR shall be paid
19 pursuant to Public Contract Code sections 20143 and 20139 and section 4 of the
20 Standard Specifications, State of California, Business, Transportation and Housing
21 Agency, May 2006 Issued by the Department of Transportation ("Caltrans Standard
22 Specifications") referred to in **Exhibit "A"** and incorporated herein by reference.

23 **6. REPRESENTATIONS BY CONTRACTOR.**

24 **6.1.** CONTRACTOR understands and agrees that COUNTY has limited knowledge in the
25 construction specified in the description of work. CONTRACTOR has represented
26 itself to be expert in these fields and understands that COUNTY is relying upon such
27 representation.

28 **6.2.** CONTRACTOR represents and warrants that it is a lawful entity possessing all required

1 licenses and authorities to do business in the State of California and perform all aspects
2 of this Agreement.

3 **6.3.** CONTRACTOR shall not commence any work under this Agreement or provide any
4 other services, or materials, in connection therewith until CONTRACTOR has received
5 written authorization from the Director of Public Works, or his/her designee (“Notice to
6 Proceed”) to do so.

7 **6.4.** CONTRACTOR represents and warrants that the people executing this Agreement on
8 behalf of CONTRACTOR have the authority of CONTRACTOR to sign this
9 Agreement and bind CONTRACTOR to the performance of all duties and obligations
10 assumed by CONTRACTOR herein.

11 **6.5.** CONTRACTOR represents and warrants that any employee, contractor, subcontractor
12 and agent who will be performing any of the duties and obligations of CONTRACTOR
13 herein possess all required licenses and authorities, as well as the experience and
14 training, to perform such tasks.

15 **6.6.** CONTRACTOR represents and warrants that the allegations contained in its Proposal
16 are true and correct.

17 **6.7.** CONTRACTOR understands that COUNTY considers the representations made herein
18 to be material and would not enter into this Agreement with CONTRACTOR if such
19 representations were not made.

20 **6.8.** Retention and Access of Books and Records. CONTRACTOR represents and warrants
21 that it shall maintain books, records, documents, reports and other materials developed
22 under this Agreement as follows:

23 **6.8.1.** CONTRACTOR shall hold and possess as the property of COUNTY all papers,
24 books, files, correspondence and other records of all kinds which at any time
25 shall come into its possession or under its control relating only to services
26 performed by CONTRACTOR under this Agreement for a minimum period of
27 five (5) years, or for any longer period required by law, from the date said
28 papers came into the possession of CONTRACTOR pursuant to this Agreement.

1 **6.8.2.** Any records or documents required to be maintained by CONTRACTOR
2 pursuant to this Agreement shall be made available to COUNTY for inspection
3 or audit, at any time during CONTRACTOR’s regular business hours provided
4 COUNTY provides CONTRACTOR with seven (7) days advanced written or
5 oral notice. Copies of such documents shall, at no cost to COUNTY, be
6 provided to COUNTY for inspection at CONTRACTOR’s address indicated for
7 receipt of notices under this Agreement.

8 **6.8.3.** CONTRACTOR shall surrender all papers maintained by CONTRACTOR
9 pursuant to Subparagraph 6.8.1 of this Agreement within thirty (30) days of
10 termination of this Agreement.

11 **6.8.4.** CONTRACTOR represents and warrants that it has not been engaged by, nor
12 will it be engaged by and owes no duty of performance to any other person or
13 entity that would constitute a conflict. For breach or violation of this warranty,
14 COUNTY shall amongst other remedies at law, have the right to terminate this
15 Agreement without liability, or at its sole discretion, to deduct from the
16 Agreement price or consideration, or otherwise recover the full amount of such
17 fee, commission, percentage brokerage fee, gift or contingent fee paid or
18 received from another entity or person.

19 **6.9.** CONTRACTOR shall perform pursuant to this Agreement in accordance with and in
20 full compliance with all applicable Federal, State and local statues, rules, regulations
21 and policies and procedures, regardless of whether they are expressly set forth in this
22 Agreement. It is understood that in the event COUNTY is investigated or audited by
23 any State or Federal governmental agency, or any other recognized
24 investigative/auditing entity, CONTRACTOR shall fully cooperate with such agencies’
25 reasonable and lawful request for information.

26 **7. TERM OF AGREEMENT.**

27 This Agreement shall commence on the date first written above and shall remain in effect until
28 the services provided as outlined in Section 3, (“SCOPE OF WORK TO BE PERFORMED BY

1 CONTRACTOR”), have been completed, unless otherwise terminated as provided for in this
2 Agreement.

3 **8. COMPENSATION.**

4 The total compensation payable under this Agreement shall be in accordance with the item
5 prices incorporated within the Proposal submitted by CONTRACTOR for labor, materials and all other
6 services related to the performance of this Agreement, attached hereto as **Exhibit “B”** and
7 incorporated herein as though fully set forth. The total compensation payable under this Agreement
8 shall not exceed «**Cost_of_Original_Contract**».

9 **9. PAYMENT AND RETENTION OF FUNDS.**

10 COUNTY shall pay CONTRACTOR for completed and approved services upon presentation
11 and approval of its itemized billing, subject to the following.

12 **9.1. Retention.**

13 **9.1.1.** In accordance with Cal. Pub. Contract Code §§ 7201 and 9203, COUNTY shall
14 generally retain five percent (5%) of the total compensation payable under this
15 Agreement until the Work to be performed has been completed in accordance
16 with this Agreement, as determined by COUNTY, and payment in full of all of
17 CONTRACTOR’s subcontractors has been certified.

18 **9.1.2.** The 5% retention amount may be exceeded if the COUNTY’s Board of
19 Supervisors has approved a finding, during a properly noticed and normally
20 scheduled public hearing conducted either prior to or concurrent with
21 authorizing this Project to go out to bid, that the Project is substantially complex
22 and therefore requires a higher retention amount than 5%. Should the retention
23 amount exceed 5% for this Project, then the actual retention amount will be
24 listed in the Plans and Specifications, along with the findings justifying the
25 increased retention amount.

26 **9.2. Substitution of Retention.**

27 **9.2.1.** CONTRACTOR may elect to substitute securities for any retention of funds by
28 COUNTY to ensure performance under this Agreement. At the request and

1 expense of CONTRACTOR, securities equivalent to the amount retained shall
2 be deposited with the COUNTY, or with a state or federally chartered bank in
3 this state as the escrow agent, who shall then return the securities to
4 CONTRACTOR once the Work to be performed has been completed in
5 accordance with this Agreement, as determined by COUNTY, and payment in
6 full of all of CONTRACTOR's subcontractors has been certified.

7 **9.2.2.** Alternatively, CONTRACTOR may request and COUNTY shall make payment
8 of retentions earned directly to the escrow agent at the expense of
9 CONTRACTOR. CONTRACTOR, at its sole cost and expense, may direct the
10 investment of the payments into securities, and CONTRACTOR shall receive
11 the interest earned on the investments upon the same terms provided for in this
12 Section for securities deposited by CONTRACTOR. Once the Work to be
13 performed has been completed in accordance with this Agreement, as
14 determined by COUNTY, and payment in full of all of CONTRACTOR's
15 subcontractors has been certified, CONTRACTOR shall receive from the
16 escrow agent all securities, interest, and payments received by the escrow agent
17 from COUNTY, pursuant to the terms of this Section.

18 **9.2.3.** Securities eligible for investment under this Section shall include those listed in
19 Cal. Gov. Code § 16430, bank or savings and loan certificates of deposit,
20 interest-bearing demand deposit accounts, standby letters of credit, or any other
21 security mutually agreed to by COUNTY and CONTRACTOR.
22 CONTRACTOR shall be the beneficial owner of any securities substituted for
23 retained funds and shall receive any interest thereon.

24 **9.2.4.** Substitution of securities shall be conducted through an Escrow Agreement
25 substantially similar to that found in Cal. Pub. Contract Code § 22300(f).

26 **9.2.5.** Notwithstanding any other provision in this Section, substitution of securities is
27 prohibited where funding for the Project, in whole or in part, will be provided by
28 the Farmers Home Administration of the United States Department of

1 Agriculture pursuant to the Consolidated Farm and Rural Development Act (7
2 U.S.C. Sec. 1921 et seq.), or where otherwise disallowed by federal law.

3 **10. METHOD OF PAYMENT.**

4 **10.1.** CONTRACTOR shall at any time prior to the fifteenth (15th) day of any month, submit
5 to COUNTY's Director of Public Works or his/her designee, a complete and accurate
6 written claim for compensation for services performed. The claim shall be in a format
7 approved by COUNTY. COUNTY shall make no payment prior to the claims being
8 approved in writing by the Director of Public Works or his/her designee.

9 **10.2.** After determining that the claim is a proper payment request, the Director of Public
10 Works, or his/her designee, shall submit to COUNTY's Auditor/Controller undisputed
11 and properly submitted claims approved for payment within ten (10) days following the
12 date the claim was submitted to his/her Department.

13 **10.3.** CONTRACTOR may expect to receive payment within a reasonable time thereafter and
14 in any event in the normal course of business within thirty (30) days after the
15 undisputed and properly submitted claim is submitted.

16 **10.4.** Any claim determined to be an improper payment request shall be returned to
17 CONTRACTOR as soon as practicable, but not later than seven (7) days, after receipt
18 with a written explanation as to why the claim is an improper request for payment.

19 **10.5.** In order for prompt payment to be made by COUNTY pursuant to Public Contract Code
20 §20104.50, CONTRACTOR must properly fill out all written claims for compensation
21 for services performed.

22 **10.6.** COUNTY shall pay interest at the legal rate set forth in Code of Civil Procedure
23 §685.010 in the event payment is not made within thirty (30) days of an undisputed
24 properly submitted request.

25 **11. INDEMNIFICATION.**

26 **11.1.** CONTRACTOR agrees to the fullest extent permitted by law to indemnify, defend,
27 protect and hold COUNTY and its representatives, officers, directors, designees,
28 employees, agents, successors and assigns harmless from any and all claims, expenses,

1 liabilities, causes of action, demands, losses, penalties, attorneys' fees and costs, in law
2 or equity, of every kind and nature whatsoever arising out of or in connection with
3 CONTRACTOR's negligent acts and omissions or willful misconduct under this
4 Agreement ("Claims"), whether or not arising from the passive negligence of
5 COUNTY, but does not include Claims that are finally determined to be the result of the
6 sole negligence or willful misconduct of COUNTY.

7 **11.2.** CONTRACTOR agrees to defend with counsel acceptable to COUNTY, indemnify and
8 hold COUNTY harmless from all Claims, including but not limited to:

9 **11.2.1.** Personal injury, including but not limited to bodily injury, emotional injury,
10 sickness or disease or death to persons including but not limited to COUNTY's
11 representatives, officers, directors, designees, employees, agents, successors and
12 assigns, subcontractors and other third parties and/or damage to property of
13 anyone (including loss of use thereof) arising out of CONTRACTOR's
14 negligent performance of, or willful misconduct surrounding, any of the terms
15 contained in this Agreement, or anyone directly or indirectly employed by
16 CONTRACTOR or anyone for whose acts CONTRACTOR may be liable;

17 **11.2.2.** Liability arising from injuries to CONTRACTOR and/or any of
18 CONTRACTOR's employees or agents arising out of CONTRACTOR's
19 negligent performance of, or willful misconduct surrounding, any of the terms
20 contained in this Agreement, or anyone directly or indirectly employed by
21 CONTRACTOR or anyone for whose acts CONTRACTOR may be liable;

22 **11.2.3.** Penalties imposed upon account of the violation of any law, order, citation, rule,
23 regulation, standard, ordinance or statute caused by the negligent action or
24 inaction, or willful misconduct of CONTRACTOR or anyone directly or
25 indirectly employed by CONTRACTOR or anyone for whose acts
26 CONTRACTOR may be liable, including but not limited to:

27 **(a)** Any loss of funding, penalties, fees, or other costs resulting from
28 CONTRACTOR's failure to adhere to Disadvantaged Business

1 Enterprise requirements and/or goals, as determined by COUNTY or
2 such other lawful entity in charge of monitoring Disadvantaged Business
3 Enterprise compliance;

4 (b) Any loss of funding, penalties, fees, or other costs resulting from
5 CONTRACTOR's failure to adhere to prevailing wage requirements, as
6 determined by COUNTY, the California Department of Industrial
7 Relations, or such other lawful entity in charge of monitoring prevailing
8 wage compliance;

9 11.2.4. Infringement of any patent rights which may be brought against COUNTY
10 arising out of CONTRACTOR's work;

11 11.2.5. Any violation or infraction by CONTRACTOR of any law, order, citation, rule,
12 regulation, standard, ordinance or statute in any way relating to the occupational
13 health or safety of employees; and

14 11.2.6. Any breach by CONTRACTOR of the terms, requirements or covenants of this
15 Agreement.

16 11.3. The indemnification provisions of this Agreement shall extend to Claims occurring after
17 this Agreement is terminated, as well as while it is in force.

18 12. **INDEPENDENT CONTRACTOR.**

19 12.1. In all situations and circumstances arising out of the terms and conditions of this
20 Agreement, CONTRACTOR is an independent contractor, and as an independent
21 contractor, the following shall apply:

22 12.2. CONTRACTOR is not an employee or agent of COUNTY and is only responsible for
23 the requirements and results specified by this Agreement.

24 12.3. CONTRACTOR shall be responsible to COUNTY only for the requirements and results
25 specified by this Agreement and except as specifically provided in this Agreement, shall
26 not be subject to COUNTY's control with respect to the physical actions or activities of
27 CONTRACTOR in fulfillment of the requirements of this Agreement.

28 12.4. CONTRACTOR is not, and shall not be, entitled to receive from, or through,

1 COUNTY, and COUNTY shall not provide, or be obligated to provide,
2 CONTRACTOR with Worker's Compensation coverage or any other type of
3 employment or worker insurance or benefit coverage required or provided by any
4 Federal, State or local law or regulation for, or normally afforded to, an employee of
5 COUNTY.

6 **12.5.** CONTRACTOR shall not be entitled to have COUNTY withhold or pay, and
7 COUNTY shall not withhold or pay, on behalf of CONTRACTOR, any tax or money
8 relating to the Social Security Old Age Pension Program, Social Security Disability
9 Program, or any other type of pension, annuity, or disability program required or
10 provided by any Federal, State or local law or regulation.

11 **12.6.** CONTRACTOR shall not be entitled to participate in, or receive any benefit from, or
12 make any claim against any COUNTY fringe benefit program, including, but not
13 limited to, COUNTY's pension plan, medical and health care plan, dental plan, life
14 insurance plan, or any other type of benefit program, plan, or coverage designated for,
15 provided to, or offered to COUNTY's employee.

16 **12.7.** COUNTY shall not withhold or pay, on behalf of CONTRACTOR, any Federal, State,
17 or local tax, including, but not limited to, any personal income tax, owed by
18 CONTRACTOR.

19 **12.8.** CONTRACTOR is, and at all times during the term of this Agreement shall represent
20 and conduct itself as, an independent contractor, not an employee of COUNTY.

21 **12.9.** CONTRACTOR shall not have the authority, express or implied, to act on behalf of,
22 bind or obligate COUNTY in any way without the written consent of COUNTY.

23 **13. INSURANCE.**

24 **13.1.** CONTRACTOR hereby agrees at its own cost and expense to procure and maintain,
25 during the entire term of this Agreement and any extended term therefore, insurance in
26 a sum acceptable to COUNTY and adequate to cover potential liabilities arising in
27 connection with the performance of this Agreement and in any event not less than the
28 minimum limit set forth in the "Minimum Insurance Amounts" attachment to the Plans

1 and Specifications which are incorporated as if set forth fully herein.

2 **13.2. Special Insurance Requirements.** All insurance required shall:

3 **13.2.1.** Be procured from California admitted insurers (licensed to do business in
4 California) with a current rating by Best's Key Rating Guide, acceptable to
5 COUNTY. A rating of at least A-VII shall be acceptable to COUNTY; lesser
6 ratings must be approved in writing by COUNTY.

7 **13.2.2.** Be primary coverage as respects COUNTY and any insurance or self-insurance
8 maintained by COUNTY shall be in excess of CONTRACTOR's insurance
9 coverage and shall not contribute to it.

10 **13.2.3.** Name COUNTY as an additional insured on all policies, except Workers'
11 Compensation, and provide that COUNTY may recover for any loss suffered by
12 COUNTY by reason of CONTRACTOR's negligence.

13 **13.2.4.** State that it is primary insurance and regards COUNTY as an additional insured
14 and contains a cross-liability or severability of interest clause.

15 **13.2.5.** Not be canceled, non-renewed or reduced in scope of coverage until after thirty
16 (30) days written notice has been given to COUNTY. However,
17 CONTRACTOR may not terminate such coverage until it provides COUNTY
18 with proof that equal or better insurance has been secured and is in place.
19 Cancellation or change without the prior written consent of COUNTY shall, at
20 the option of COUNTY, be grounds for termination of this Agreement.

21 **13.2.6.** If this Agreement remains in effect more than one (1) year from the date of its
22 original execution, COUNTY may, at its sole discretion, require an increase in
23 the amount of liability insurance to the level then customary in similar
24 COUNTY Agreements by giving sixty (60) days notice to CONTRACTOR.

25 **13.3. Additional Insurance Requirements.**

26 **13.3.1.** COUNTY is to be notified immediately of all insurance claims. COUNTY is
27 also to be notified if any aggregate insurance limit is exceeded.

28 **13.3.2.** The comprehensive or commercial general liability shall contain a provision of

1 endorsements stating that such insurance:

- 2 **(a)** Includes contractual liability;
- 3 **(b)** Does not contain any exclusions as to loss or damage to property caused
4 by explosion or resulting from collapse of buildings or structures or
5 damage to property underground, commonly referred to by insurers as
6 the “XCU Hazards”;
- 7 **(c)** Does not contain a “pro rata” provision which looks to limit the insurer’s
8 liability to the total proportion that its policy limits bear to the total
9 coverage available to the insured;
- 10 **(d)** Does not contain an “excess only” clause which requires the exhaustion
11 of other insurance prior to providing coverage;
- 12 **(e)** Does not contain an “escape clause” which extinguishes the insurer’s
13 liability if the loss is covered by other insurance;
- 14 **(f)** Includes COUNTY as an additional insured; and
- 15 **(g)** States that it is primary insurance and regards COUNTY as an additional
16 insured and contains a cross-liability or severability of interest clause.

17 **13.4. Deposit of Insurance Policy.** Promptly on issuance, reissuance, or renewal of any
18 insurance policy required by this Agreement, CONTRACTOR shall, if requested by
19 COUNTY, cause to be given to COUNTY satisfactory evidence that insurance policy
20 premiums have been paid together with a duplicate copy of the policy or a certificate
21 evidencing the policy and executed by the insurance company issuing the policy or its
22 authorized agent.

23 **13.5. Certificates of Insurance.** Complete copies of certificates of insurance for all required
24 coverages including additional insured endorsements shall be attached hereto as **Exhibit**
25 **“C”** and incorporated herein as though fully set forth.

26 **13.6. Additional Insurance.** Nothing in this, or any other provision of this Agreement, shall
27 be construed to preclude CONTRACTOR from obtaining and maintaining any
28 additional insurance policies in addition to those required pursuant to this Agreement.

1 **14. WORKERS' COMPENSATION CERTIFICATION.**

2 **14.1.** Prior to the commencement of work, CONTRACTOR shall sign and file with
3 COUNTY the following certification: "I am aware of the provisions of California Labor
4 Code §§3700 et seq. which require every employer to be insured against liability for
5 workers' compensation or to undertake self-insurance in accordance with the provisions
6 of that code, and I will comply with such provisions before commencing the
7 performance of the work of this contract."

8 **14.2.** This certification is included in this Agreement and signature of the Agreement shall
9 constitute signing and filing of the certificate.

10 **14.3.** CONTRACTOR understands and agrees that any and all employees, regardless of hire
11 date, shall be covered by Workers' Compensation pursuant to statutory requirements
12 prior to beginning work on the Project.

13 **14.4.** If CONTRACTOR has no employees, initial here: _____.

14 **15. WARRANTY.**

15 **15.1. One Year Warranty.** CONTRACTOR agrees to provide a one-year warranty for all of
16 its work and component parts and guarantees that all work shall be performed in a
17 professional and workman-like manner and be free from defects. CONTRACTOR
18 guarantees to timely correct all work performed by it under this Agreement which
19 COUNTY determines to be defective in design, material and/or workmanship within a
20 period of one (1) year from the date of the completion of the Work. The warranties set
21 forth in this Agreement shall be in addition to, and not in lieu of, all other statutory and
22 case law warranties and obligations of CONTRACTOR. CONTRACTOR expressly
23 agrees that all warranties made by CONTRACTOR, all obligations under this
24 Agreement and all remedies for breach of such warranties shall survive this Agreement
25 in the event it is terminated or expires for any reason prior to the running of the full
26 warranty periods listed above.

27 **15.2. Materials.** All materials furnished by CONTRACTOR shall be new, manufactured
28 during the current year, of first quality and carrying full manufacturer's warranty.

1 CONTRACTOR shall be responsible for any expiration of manufacturer or other
2 warranties of material or equipment being supplied for this Agreement.
3 CONTRACTOR guarantees that all warranties of material and equipment shall become
4 effective when the project is accepted by COUNTY's Board of Supervisors, not at time
5 of installation by CONTRACTOR.

6 **15.3. Manufacturers' Warranty Information.** CONTRACTOR agrees to promptly provide
7 such information and maintenance recommendations to COUNTY at the inception of
8 CONTRACTOR's work to the extent such information is reasonably available.

9 **16. DEFAULT AND REMEDIES.**

10 **16.1. Default.** In the event that (i) CONTRACTOR files a petition requesting relief under
11 any bankruptcy act, or is adjudged as bankrupt, or makes a general assignment for the
12 benefit of creditors or has a receiver appointed on account of its insolvency, or (ii)
13 CONTRACTOR refuses or is unable, for whatever reason, to supply enough properly
14 skilled workers or proper materials to complete the Project, or (iii) CONTRACTOR
15 fails to follow the directions of COUNTY, or (iv) CONTRACTOR fails to make prompt
16 payment to its subcontractors and suppliers for materials or labor supplied or permits
17 any lien to be imposed upon all or any portion of the Project, or (v) CONTRACTOR
18 disregards any laws or orders of any public or private authority having jurisdiction over
19 the Work or the Project, or (vi) CONTRACTOR fails to perform in accordance with
20 any of the terms of this Agreement or breaches any provision of this Agreement,
21 COUNTY may give notice of such failure or breach to CONTRACTOR, identifying the
22 failure or breach of this Agreement. Should any such failure or breach continue for
23 twenty-four (24) hours after delivery of notice without a good faith effort on the part of
24 CONTRACTOR to commence all necessary corrective action, or should such a breach
25 continue despite CONTRACTOR's efforts for forty-eight (48) hours, then at that time
26 such failure shall be deemed a default by CONTRACTOR under this Agreement and
27 COUNTY shall have all rights and remedies available at law or in equity, including the
28 right to terminate this Agreement. Without limiting its rights and remedies, COUNTY

1 may then proceed as follows:

2 **16.1.1.** Without terminating this Agreement or the obligations of CONTRACTOR
3 hereunder as to all of the Work required to be performed or furnished by
4 CONTRACTOR pursuant to this Agreement, COUNTY may require
5 CONTRACTOR, at CONTRACTOR's expense, to cure such default(s) as may
6 exist in the performance of CONTRACTOR's obligations hereunder within
7 forty-eight (48) hours after such default(s) has/have occurred including but not
8 limited to repairing, replacing and correcting material or Work determined by
9 COUNTY to be defective or not complying with the requirements of this
10 Agreement. Should CONTRACTOR fail to timely repair, replace and/or correct
11 non-complying or defective materials and workmanship or otherwise cure its
12 default(s) hereunder, and in the case of emergencies in which case COUNTY
13 may act immediately if CONTRACTOR is not available or is not responding,
14 and without further notice, COUNTY may make required repairs, replacements
15 and other corrections or otherwise remedy the default by CONTRACTOR
16 pursuant to the subparagraph below.

17 **16.1.2.** Without terminating this Agreement or the obligations of CONTRACTOR
18 hereunder as to all of the Work required to be performed or furnished by
19 CONTRACTOR pursuant to this Agreement, COUNTY may engage another
20 contractor to perform such portion of CONTRACTOR's Work required
21 pursuant to this Agreement or furnish any materials or other items required
22 hereunder as COUNTY in its sole discretion may deem necessary to avoid delay
23 in the progress of the Work, and in connection therewith, COUNTY may
24 perform such Work or any portion thereof itself or have the same performed by
25 others and COUNTY may procure all necessary materials, equipment or other
26 items required for the continued progress of such Work. The costs incurred by
27 COUNTY as a result of engaging another contractor shall be deducted from the
28 compensation payable pursuant to this Agreement and if COUNTY's costs

1 exceed or may reasonably be anticipated to exceed the balance of the
2 compensation due to CONTRACTOR for such work, such excess, or anticipated
3 excess, shall be immediately due and owing from CONTRACTOR to COUNTY
4 and may be withheld from any funds due to CONTRACTOR pursuant to this
5 Agreement or any other agreement.

6 **16.1.3.** COUNTY may terminate CONTRACTOR's right to perform upon written
7 notice and COUNTY shall then have the option of completing the Work or any
8 portion thereof by exercise of its interest under the performance bond issued in
9 favor by CONTRACTOR, or having such Work in whole or in part be
10 completed by others for CONTRACTOR's account. A calculation shall take
11 place at the conclusion of the Project wherein to the degree the sum of
12 COUNTY's costs and any amounts paid to complete the Project exceed the
13 compensation payable pursuant to this Agreement, then any such excess shall be
14 immediately due and owing from CONTRACTOR to COUNTY.

15 **16.2.** Damages. CONTRACTOR shall be liable for all damages suffered by COUNTY by
16 reason of CONTRACTOR's default in any provision of this Agreement and the exercise
17 of COUNTY of its option to terminate this Agreement shall not release
18 CONTRACTOR of such liability. CONTRACTOR shall have no right to receive any
19 further payment after a default has occurred until such time as the Work to be
20 performed by CONTRACTOR pursuant hereto has been completed and accepted by
21 COUNTY and damages suffered by COUNTY, if any, ascertained. Damages shall
22 include by way of illustration, but not of exclusion, COUNTY's costs of completing the
23 Work which exceeds the compensation payable pursuant to this Agreement, other
24 general, liquidated, special or consequential damages, attorney fees and costs.

25 **16.3.** Actions After Default. Should COUNTY exercise any of its options, remedies or rights
26 granted pursuant to the terms of this Agreement in the event of a default by
27 CONTRACTOR, COUNTY at its sole election may, but shall not be obligated to, use
28 any materials, supplies, tools or equipment on the work site which belong to

1 CONTRACTOR to complete the Work required to be completed by CONTRACTOR,
2 whether such work is completed by COUNTY or by others, and CONTRACTOR
3 agrees that it shall not remove such materials, supplies, tools and equipment from the
4 work site unless directed in writing by COUNTY to do so.

5 **16.4. Limit on Force Majeure Damages.** CONTRACTOR shall not be responsible for
6 repairing or restoring damage to work caused by an act of God in excess of five (5)
7 percent of the contract amount, provided that the work damaged is built in accordance
8 with accepted and applicable building standards and the plans and specifications of
9 COUNTY. In the event of such damage, COUNTY may, at its option, elect to
10 terminate this Agreement. For purposes of this Agreement, an “act of God” shall be
11 defined as an earthquake in excess of 3.5 on the Richter Scale and a tidal wave.

12 **16.5. Resolution of Claims.** COUNTY and CONTRACTOR agree to follow and comply
13 with the mediation, arbitration, claim, civil action procedure and trial de novo
14 provisions set forth in California Public Contracts Code §§ 9204 and 20104 – 20104.6.

15 **16.6. No Limitation of Rights.** The options and rights granted to COUNTY herein shall not
16 be deemed as limitations upon the other rights and remedies of COUNTY in the event
17 of a failure of performance or breach by CONTRACTOR, and COUNTY shall be
18 entitled to exercise the rights and remedies hereinabove specified and all other rights
19 and remedies which may be provided in this Agreement or by law or in equity, either
20 cumulatively or consecutively, and in such order as COUNTY in its sole discretion shall
21 determine.

22 **17. NON-DISCRIMINATION.**

23 **17.1.** During the performance of this Agreement, CONTRACTOR and its subcontractors
24 shall not unlawfully discriminate, harass or allow harassment against any employee or
25 applicant for employment because of sex, race, color, ancestry, religious creed, national
26 origin, physical disability (including HIV and AIDS), mental disability, medical
27 condition (cancer), age (over forty (40)), marital status and denial of family care leave.

28 **17.2.** CONTRACTOR and its subcontractors shall insure that the evaluation and treatment of

1 their employees and applicants for employment are free from such discrimination and
2 harassment.

3 **17.3.** CONTRACTOR and its subcontractors shall comply with the provisions of the Fair
4 Employment and Housing Act (Gov. Code §12990 (a-f) et seq.) and the applicable
5 regulations promulgated thereunder (California Code of Regulations, Title 2, Section
6 7285 et seq.).

7 **17.4.** The applicable regulations of the Fair Employment and Housing Commission
8 implementing Government Code §12990 (a-f), set forth in Chapter 5 of Division 4 of
9 Title 2 of the California Code of Regulations, are incorporated into this Agreement by
10 reference and made a part hereof as if set forth in full.

11 **17.5.** The applicable regulations of Section 504 of the Rehabilitation Act of 1973 (29 U.S.C.
12 §794 (a)) are incorporated into this Agreement by reference and made a part hereof as if
13 set forth in full.

14 **17.6.** CONTRACTOR and its subcontractors shall give written notice of their obligations
15 under this clause to labor organizations with which they have a collective bargaining or
16 other agreement.

17 **17.7.** CONTRACTOR shall include the nondiscrimination and compliance provisions of this
18 clause in all subcontracts to perform Work under this Agreement.

19 **18. DISADVANTAGED BUSINESS ENTITY COMPLIANCE.**

20 **18.1.** When applicable, CONTRACTOR and its subcontractors shall reference and abide by
21 the guidance and Disadvantaged Business Enterprise (“DBE”) specifications contained
22 in the California Department of Transportation’s Standard Specifications.

23 **18.2.** CONTRACTOR represents and warrants that is has fully read the applicable DBE
24 requirements pertaining to this Project and has fully and accurately completed any and
25 all required DBE forms.

26 **18.3.** CONTRACTOR represents and warrants that it will comply with all applicable DBE
27 requirements for this Project.

28 **18.4.** CONTRACTOR shall comply with the applicable DBE provisions attached hereto as

1 **Exhibit “D”** and incorporated by this reference as though fully set forth herein.

2 **18.5.** If any state or federal funds are withheld from COUNTY or not reimbursed to
3 COUNTY due to CONTRACTOR’s failure to either comply with the DBE
4 requirements set forth in the RFP and this Agreement, or to meet the mandatory DBE
5 goals as determined by COUNTY, Caltrans, the Federal Highway Administration,
6 and/or any other state or federal agency contributing funds to the Project, then
7 CONTRACTOR shall fully reimburse COUNTY the amount of funding lost.
8 COUNTY reserves the right to deduct any such loss in funding from the amount of
9 compensation due to CONTRACTOR under this Agreement.

10 **18.6.** In addition to the above, CONTRACTOR’s failure to comply with DBE
11 requirements/goals shall subject it to such sanctions as are permitted by law, which may
12 include, but shall not be limited to the following:

13 **18.6.1.** Termination of this Agreement;

14 **18.6.2.** Withholding monthly progress payments;

15 **18.6.3.** Denial of payment for any portion of the Project that was committed at the time
16 of the execution of this Agreement to be performed by a DBE subcontractor, but
17 was completed by CONTRACTOR or a substitute non-DBE subcontractor;

18 **18.6.4.** Compensatory, special, incidental, liquidated and other damages; and/or

19 **18.6.5.** Designation of CONTRACTOR as “nonresponsible,” and disqualification from
20 bidding on future public works projects advertised by COUNTY.

21 **19. PREVAILING WAGE.**

22 **19.1.** CONTRACTOR and its subcontractors shall pay all workers employed on the Project
23 the higher of either the rates determined by the Director of the California Department of
24 Industrial Relations (“DIR”) or, when applicable, the Davis-Bacon Federal wage rates
25 as supplemented by the Department of Labor regulations. The Davis-Bacon Federal
26 wage rates are attached to the RFP. Copies of the State prevailing rate of per diem
27 wages are on file with the Department of Industrial Relations, Division of
28 Apprenticeship Standards, 445 Golden Gate Avenue, San Francisco, California, and at

1 COUNTY's Department of Public Works, and are available to CONTRACTOR and any
2 other interested party upon request. CONTRACTOR shall post the prevailing rate of
3 per diem wages to be posted at the Project site.

4 **19.2.** CONTRACTOR is responsible for compliance with the provisions herein.

5 **19.3.** Mandatory Registration with the Department of Industrial Relations – NEW
6 REQUIREMENTS PURSUANT TO SB 854.

7 **19.3.1.** CONTRACTOR and its subcontractors shall register with the DIR and pay all
8 applicable fees as set forth in Labor Code section 1725.5.

9 **19.3.2.** CONTRACTOR and its subcontractors acknowledge that they shall not be listed
10 on any bid proposal for a public works project (submitted on or after March 1,
11 2015) unless registered with the DIR pursuant to Labor Code section 1725.5.
12 The requirements of this section shall apply unless one of the limited exceptions
13 provided under Labor Code Section 1771.1(a) applies.

14 **19.3.3.** CONTRACTOR and its subcontractors acknowledge that they shall not be
15 awarded any contract for public work on a public works project (awarded on or
16 after April 1, 2015) unless registered with the DIR pursuant to Labor Code
17 section 1725.5.

18 **19.3.4.** The Project described herein is subject to compliance monitoring and
19 enforcement with the DIR.

20 **19.3.5.** For further information concerning compliance with SB 854, please visit:
21 <http://www.dir.ca.gov/Public-Works/SB854.html>.

22 **19.4.** Cognizance of Violations by County.

23 **19.4.1.** CONTRACTOR understands and agrees that COUNTY shall take cognizance of
24 violations of Chapter 1 of Part 7 of Division 2 of the California Labor Code
25 committed in the course of the execution of this Agreement, and shall promptly
26 report any suspected violations to the Labor Commissioner.

27 **19.4.2.** If CONTRACTOR determines as a result of its own investigation that there has
28 been a violation of Chapter 1 of Part 7 of Division 2 of the California Labor

1 Code and withholds payment to CONTRACTOR, the procedures in California
2 Labor Code §1771.6 shall be followed.

3 **19.4.3.** CONTRACTOR may bring an action in a court of competent jurisdiction to
4 recover from COUNTY the difference between the wages actually paid to an
5 employee and the wages that were required to be paid to an employee pursuant
6 to Chapter 1 of Part 7 of Division 2 of the California Labor Code, any penalties
7 required to be paid pursuant to Chapter 1 of Part 7 of Division 2 of the
8 California Labor Code, and costs and attorney’s fees related to the action, if
9 either of the following is true:

10 (a) COUNTY previously affirmatively represented to CONTRACTOR in
11 writing, in the call for bids, or otherwise, that the Work was not a “public
12 work,” as defined in Chapter 1 of Part 7 of Division 2 of the California
13 Labor Code; or

14 (b) COUNTY received actual written notice from the Department of
15 Industrial Relations that the Work is a “public work,” as defined in
16 Chapter 1 of Part 7 of Division 2 of the California Labor Code, and
17 failed to disclose that information to CONTRACTOR before the bid
18 opening or award.

19 **19.5. Labor Compliance Rates and Payroll Records.**

20 **19.5.1.** CONTRACTOR agrees to comply with §§1775 and 1776 of the California
21 Labor Code relating to the payment of prevailing wage and the maintenance of
22 certified payroll records and to make the certified payroll records available for
23 inspection at all reasonable hours at CONTRACTOR’s principal office. The
24 responsibility for compliance with these provisions is fixed with
25 CONTRACTOR. CONTRACTOR understands and agrees that it shall, as a
26 penalty to COUNTY, forfeit specific monetary fines for each worker paid less
27 than the prevailing wage rates as determined by the Labor Commissioner for the
28 work or craft in which the worker is employed for any Work done pursuant to

1 this Agreement.

2 **19.5.2. Prevailing Wage Compliance For those Projects subject to DIR Monitoring and**
3 *Enforcement.* CONTRACTOR has reviewed and agrees to comply with any
4 applicable provisions for those Projects subject to Department of Industrial
5 Relations (DIR) Monitoring and Enforcement of prevailing wages. COUNTY
6 hereby notifies CONTRACTOR that CONTRACTOR is responsible for
7 complying with the requirements of Senate Bill 854 (SB854) regarding certified
8 payroll record reporting. Further information concerning the requirements of
9 SB854 is available on the DIR website located at: <http://www.dir.ca.gov/Public-Works/PublicWorksEnforcement.html>.

10
11 **19.5.3.** CONTRACTOR shall be liable for penalties pursuant to this section when a
12 subcontractor on the Project fails to pay its workers the general prevailing rate
13 of per diem wages and any of the following conditions are met:

- 14 (a) CONTRACTOR had knowledge of that failure of the subcontractor to
15 pay the specified prevailing rate of wages to those workers; or
16 (b) CONTRACTOR fails to comply with the following requirement: The
17 contract executed between CONTRACTOR and the subcontractor for the
18 performance of Work on the Project shall include a copy of the
19 provisions of California Labor Code §§1771, 1775, 1776, 1777.5, 1813
20 and 1815; and
21 (c) CONTRACTOR fails to comply with the following requirement:
22 CONTRACTOR shall monitor the payment of the specified general
23 prevailing rate of per diem wages by the subcontractor to the employees,
24 by periodic review of the certified payroll records of the subcontractor;
25 and
26 (d) Upon becoming aware of the failure of the subcontractor to pay his or
27 her workers the specified prevailing rate of wages, CONTRACTOR shall
28 diligently take corrective action to halt or rectify the failure, including,

1 but not limited to, retaining sufficient funds due the subcontractor for
2 work performed on the public works project; and

3 (e) Prior to making final payment to the subcontractor for Work performed
4 on the Project, CONTRACTOR shall obtain an affidavit signed under
5 penalty of perjury from the subcontractor that the subcontractor has paid
6 the specified general prevailing rate of per diem wages to his or her
7 employees on the Project and any amounts due pursuant to California
8 Labor Code §1813.

9 **19.6. Work Day and Work Week Requirements.** CONTRACTOR agrees to comply with
10 §§1810 through 1815 of the California Labor Code and, when applicable, sections 103
11 and 107 of the Contract Work Hours and Safety Standards Act, 40 U.S.C. §§3700 et
12 seq., as supplemented by the Department of Labor regulations, which provide that
13 CONTRACTOR's workers and its subcontractor's workers may not be required or
14 permitted to work more than eight (8) hours in any one (1) calendar day and forty (40)
15 hours in any one (1) calendar week. Further, work performed by employees of
16 CONTRACTOR or its subcontractor in excess of eight (8) hours per day, and forty (40)
17 hours during any one (1) week, shall be compensated for all hours worked in excess of
18 eight (8) hours per day at not less than one and one-half (1½) times the basic rate of
19 pay. The responsibility for compliance with these provisions is fixed with
20 CONTRACTOR. CONTRACTOR understands and agrees that it shall, as a penalty to
21 COUNTY, forfeit specific monetary fines to COUNTY should CONTRACTOR or its
22 subcontractors fail to comply with the provisions contained within this Paragraph.

23 **19.7. Apprenticeship Requirements.**

24 **19.7.1.** CONTRACTOR agrees to comply with §§1777.5, 1777.6 and 1777.7 of the
25 California Labor Code relating to the employment of apprentices and to provide
26 COUNTY with copies of any contract award information and verified
27 statements of the journeyman and apprentice hours performed pursuant to this
28 Agreement as required by §1777.5(e). The responsibility for compliance with

1 these provisions is fixed with CONTRACTOR for all apprenticeable
2 occupations, where journeymen in the craft are employed on the public work, in
3 a ratio of not less than one (1) apprentice for each five (5) journeymen (unless
4 an exemption is granted in accordance with §1777.5) and CONTRACTOR and
5 its subcontractors shall not discriminate among otherwise qualified employees
6 as indentured apprentices on any public work solely on the ground of race,
7 religious creed, color, national origin, ancestry, sex, or age, except as provided
8 in California Labor Code §3077. Only apprentices, as defined in California
9 Labor Code §3077, who are in training under apprenticeship standards and who
10 have signed written apprentice agreements will be employed on public works in
11 apprenticeable occupations. This section shall not be enforced if the not-to-
12 exceed amount of this Agreement set forth and/or incorporated in the
13 “COMPENSATION” Section is less than thirty thousand dollars (\$30,000).

14 **19.7.2.** If the Project falls within the jurisdiction of California Labor Code §1777.5,
15 COUNTY shall, within five (5) days of the award, send a copy of the award to
16 the Division of Apprenticeship Standards. In addition, COUNTY shall notify
17 the Division of Apprenticeship Standards of a finding of any discrepancy
18 regarding the ratio of apprentices to journeymen within five (5) days of the
19 finding.

20 **19.8. Labor Standards Compliance Requirements.**

21 **19.8.1.** It is CONTRACTOR’s responsibility to provide all labor compliance
22 documentation from its subcontractors completely and accurately in a timely
23 manner. CONTRACTOR is responsible to review promptly and then forward
24 on all required documentation to COUNTY per the time schedules in the 1775
25 Handout. Included with the Labor Compliance Handout, COUNTY will provide
26 training, documentation requirements, forms, etc., at the preconstruction
27 conference or at a time designated by COUNTY.

28 **19.8.2.** In the event, during the review process of labor compliance documentation from

1 COUNTY's labor compliance monitor, inaccurate, missing or incomplete
2 information was provided, the labor compliance monitor will request from
3 CONTRACTOR the items, revisions and documentation needed. The cost of
4 this additional labor compliance enforcement shall be borne by
5 CONTRACTOR.

6 **20. INELIGIBILITY.**

7 **20.1.** CONTRACTOR represents and warrants that it and its subcontractors are not ineligible
8 to work for COUNTY due to violations of Labor Code §§1777.1 and 1777.7.

9 **20.2.** If CONTRACTOR is deemed ineligible to perform work on public works projects
10 pursuant to Labor Code Sections 1777.1 or 1777.7, then CONTRACTOR shall be
11 prohibited from bidding on, being awarded an agreement for, or performing work as a
12 subcontractor on this Project, or any other public works project within the state of
13 California.

14 **21. SIGNAGE REQUIREMENTS.**

15 **21.1. Project Identity Signage.** CONTRACTOR is required to provide and install the
16 required project identity signage as detailed in the Plans and Specifications, in the size
17 and at the location indicated by the Director of Public Works or his/her designee, and to
18 maintain the signage in good condition for the duration of the Project. The signage may
19 not be removed until the Notice of Completion is recorded or by written direction of the
20 Director of Public Works or his/her designee.

21 **21.2. Required Employee Signage and Posters.** CONTRACTOR is required to provide and
22 install the Federal and State required employee posters and the required material
23 pertaining to the required labor standards provisions are posted (including, but not
24 limited to, WH-1321, OSHA 3165 and OFCCP-English, EFCCP-Spanish) at the
25 worksite in a prominent and accessible place.

26 **21.3. Section 3 Compliant Signage.** If required by COUNTY, CONTRACTOR is directed to
27 provide and install the "Offer for Employment" signage as detailed in the Plans and
28 Specifications in the size and at the location indicated by the Director of Public Works

1 or his/her designee and to maintain the signage in good condition for the duration of the
2 Project. The signage may not be removed until the Notice of Completion is recorded or
3 by written direction of the Director of Public Works or his/her designee.

4 **22. CONFLICT OF INTEREST AND GRATUITIES.**

5 **22.1.** CONTRACTOR agrees that it presently has no interest and shall not acquire any
6 interest, direct or indirect, which could conflict in any manner or degree with the
7 performance of services required to be performed under this Agreement.
8 CONTRACTOR further agrees that in the performance of this Agreement, no person
9 having any such interest shall be employed.

10 **22.2.** CONTRACTOR agrees to designate such person or persons who have responsibility for
11 carrying out the services under this Agreement and that such person or persons as may
12 be designated shall take any and all actions necessary to comply with COUNTY's
13 Conflict of Interest Code adopted pursuant to California Government Code §81000 to
14 the extent required thereunder.

15 **22.3.** If it is found, after notice and hearing by COUNTY, that gratuities (in the form of
16 entertainment., gifts, or otherwise) were offered or given by CONTRACTOR, or any
17 agent or representative of CONTRACTOR, to any officer, employee or agent of
18 COUNTY with a view toward securing a contract or securing favorable treatment with
19 respect to the awarding or amending or the making of any determinations with respect
20 to the performance of this Agreement, COUNTY may, by written notice to
21 CONTRACTOR, terminate the right of CONTRACTOR to proceed under this
22 Agreement and/or may pursue such other rights and remedies provided by law or under
23 this Agreement.

24 **22.4.** In the event this Agreement is terminated as provided herein, COUNTY shall be
25 entitled to:

26 **22.4.1.** Pursue the same remedies against CONTRACTOR as it could pursue in the
27 event of a breach of the Agreement by CONTRACTOR; and

28 **22.4.2.** As a penalty in addition to any other damages to which it may be entitled by

1 law, to exemplary damages in an amount (as determined by COUNTY) which
2 shall be not less than three (3) nor more than ten (10) times the costs incurred by
3 CONTRACTOR in providing any such gratuities to any such officer, employee
4 or agent.

5 **23. HOUSING AND URBAN DEVELOPMENT ACT COMPLIANCE.**

6 When applicable, CONTRACTOR agrees to comply with Section 3 of the Housing and Urban
7 Development Act of 1968 (42 U.S.C. 3601 et seq.) which provides that to the greatest extent feasible,
8 CONTRACTOR shall provide job training, employment and contracting opportunities for low- or
9 very-low income residents in connection with the Project. The responsibility for compliance with
10 these provisions is fixed with CONTRACTOR.

11 **24. COPELAND "ANTI-KICKBACK" ACT COMPLIANCE.**

12 When applicable, CONTRACTOR agrees to comply with the Copeland Act
13 ([18 USC §874](#) and [40 USC §276c; 29 C.F.R. Part 3](#)) which precludes CONTRACTOR and its
14 subcontractors from in any way inducing an employee to give up any part of the compensation to
15 which he or she is entitled under his or her contract of employment. CONTRACTOR and its
16 subcontractors shall submit a weekly statement of the wages paid to each employee performing on
17 covered work during the preceding payroll period. CONTRACTOR understands and agrees that
18 should CONTRACTOR its subcontractors induce an employee working on a covered contract to give
19 up any part of the compensation to which he or she is entitled, the inducing party may be subject to a
20 five thousand dollar (\$5,000) fine, or imprisonment for up to five (5) years, or both. CONTRACTOR
21 also understands and agrees that willful falsification of the statement of compliance may subject the
22 employer to civil or criminal prosecution and may be cause for contract termination or debarment. The
23 responsibility for compliance with these provisions is fixed with CONTRACTOR.

24 **25. FAIR LABOR STANDARDS ACT COMPLIANCE.**

25 When applicable, CONTRACTOR agrees to comply with the Fair Labor Standards Act of 1938
26 as amended (29 U.S.C. 201 et seq.) which establishes minimum wage, overtime pay, recordkeeping,
27 and youth employment standards affecting full-time and part-time workers on the Project. The
28 responsibility for compliance with these provisions is fixed with CONTRACTOR.

1 **26. CERTIFICATION REGARDING DEBARMENT, SUSPENSION AND OTHER**
2 **RESPONSIBILITY MATTERS.**

3 When applicable, CONTRACTOR agrees to execute a certification regarding debarment,
4 suspension and other responsibility matters. The responsibility for compliance with this provision is
5 fixed with CONTRACTOR.

6 **27. FEDERAL EQUAL EMPLOYMENT OPPORTUNITY CONSTRUCTION CONTRACT**
7 **SPECIFICATIONS.**

8 When applicable, CONTRACTOR agrees to incorporate the notice set forth in paragraph (d) of
9 41 C.F.R. 60-4.2 relating to the “Equal Opportunity Clause” and the “Standard Federal Equal
10 Employment Specifications.” The responsibility for compliance with this provision is fixed with
11 CONTRACTOR.

12 **28. CLEAN AIR ACT AND THE FEDERAL WATER POLLUTION CONTROL ACT.**

13 When applicable, CONTRACTOR agrees to comply with all applicable standards, orders or
14 regulations issued pursuant to the Clean Air Act (42 U.S.C. 7401 et seq.), the Federal Water Pollution
15 Control Act as amended (33 U.S.C. 1251 et seq.), Presidential Executive Order 11738 and
16 Environmental Protection Agency regulations set forth at 40 C.F.R. Part 15. CONTRACTOR
17 understands and agrees that violations shall be reported to the Federal awarding agency and the
18 Regional Office of the Environmental Protection Agency. The responsibility for compliance with
19 these provisions is fixed with CONTRACTOR.

20 **29. PROHIBITION ON THE USE OF FEDERAL FUNDS FOR LOBBYING.**

21 When applicable, CONTRACTOR shall file the required certification. Each tier certifies to the
22 tier above that it will not and has not used Federal appropriated funds to pay any person or
23 organization for influencing or attempting to influence an officer or employee of any agency, a
24 member of Congress, officer or employee of Congress, or an employee of a member of Congress in
25 connection with obtaining any Federal contract, grant or any other award covered by 31 U.S.C. 1352.
26 Each tier shall also disclose any lobbying with non-Federal funds that takes place in connection with
27 obtaining any Federal award. Such disclosures are forwarded from tier to tier up to the recipient. The
28 responsibility for compliance with this provision is fixed with CONTRACTOR.

1 **30. FEDERAL EMPLOYMENT ELIGIBILITY VERIFICATION.**

2 CONTRACTOR shall verify name, date of birth and social security number, along with
3 immigration information for non-citizens in order to verify the identity and employment eligibility of
4 both citizen and non-citizen new hires. The responsibility for compliance with this provision is fixed
5 with CONTRACTOR.

6 **31. THE CIVIL RIGHTS, HCD AND AGE DISCRIMINATION ACT ASSURANCES.**

7 **31.1.** During the performance of this Agreement, CONTRACTOR assures that no otherwise
8 qualified person shall be excluded from participation or employment, denied program
9 benefits or be subjected to discrimination based on race, color, national origin, gender,
10 age or handicap, under any program or activity funded by this Agreement, as required
11 by Title VI of the Civil Rights Act of 1964, Title I of the Housing and Community
12 Development Act of 1974, as amended, and the Age Discrimination Act of 1975, and
13 all implementing regulations. The responsibility for compliance with these provisions
14 is fixed with CONTRACTOR.

15 **31.2.** CONTRACTOR and its subcontractors shall not discriminate on the basis of race, color,
16 national origin, or sex in the performance of this Agreement. CONTRACTOR shall
17 carry out the applicable requirements of 49 C.F.R. Chapter 26 in the award and
18 administration of Department of Transportation assisted contracts. Failure by
19 CONTRACTOR to carry out these requirements is a material breach of this Agreement,
20 which may result in the termination of this Agreement, or such other remedy as
21 COUNTY deems appropriate. CONTRACTOR shall include the nondiscrimination and
22 compliance provisions of this Paragraph in all subcontracts to perform Work under this
23 Agreement.

24 **32. FEDERAL EQUAL EMPLOYMENT OPPORTUNITY REQUIREMENTS.**

25 **32.1.** CONTRACTOR hereby agrees that it will incorporate or cause to be incorporated into
26 any contract for construction work, or modification thereof, as defined in the regulations
27 of the Secretary of Labor at 41 C.F.R. Chapter 60, which is paid for in whole or in part
28 with funds obtained from the Federal Government or borrowed on the credit of the

1 Federal Government pursuant to a grant, contract, loan insurance, or guarantee, or
2 undertaken pursuant to any Federal program involving such grant, contract, loan,
3 insurance, or guarantee, the following equal opportunity clause. For the purposes of
4 this Subsection, the term “contractor” shall refer to CONTRACTOR, and the term
5 “contract” shall refer to this Agreement:

6 *“During the performance of this contract, the Contractor agrees as follows:*

7 *(1) The contractor will not discriminate against any employee or applicant for*
8 *employment because of race, color, religion, sex, or national origin. The contractor*
9 *will take affirmative action to ensure that applicants are employed, and that*
10 *employees are treated during employment, without regard to their race, color,*
11 *religion, sex, or national origin. Such action shall include, but not be limited to the*
12 *following: Employment, upgrading, demotion, or transfer, recruitment or*
13 *recruitment advertising; layoff or termination; rates of pay or other forms of*
14 *compensation; and selection for training, including apprenticeship. The contractor*
15 *agrees to post in conspicuous places, available to employees and applicants for*
16 *employment, notices to be provided by the contracting officer setting forth the*
17 *provisions of this nondiscrimination clause.*

18 *(2) The contractor will, in all solicitations or advertisements for employees placed by*
19 *or on behalf of the contractor, state that all qualified applicants will receive*
20 *consideration for employment without regard to race, color, religion, sex, or*
21 *national origin.*

22 *(3) The contractor will send to each labor union or representative of workers with*
23 *which he has a collective bargaining agreement or other contract or understanding,*
24 *a notice to be provided by the agency contracting officer, advising the labor union*
25 *or workers' representative of the contractor's commitments under section 202 of*
26 *Executive Order 11246 of September 24, 1965, and shall post copies of the notice in*
27 *conspicuous places available to employees and applicants for employment.*

28 *(4) The contractor will comply with all provisions of Executive Order 11246 of*

1 September 24, 1965, and of the rules, regulations, and relevant orders of the
2 Secretary of Labor.

3 (5) The contractor will furnish all information and reports required by Executive Order
4 11246 of September 24, 1965, and by the rules, regulations, and orders of the
5 Secretary of Labor, or pursuant thereto, and will permit access to his books,
6 records, and accounts by the contracting agency and the Secretary of Labor for
7 purposes of investigation to ascertain compliance with such rules, regulations, and
8 orders.

9 (6) In the event of the contractor's non-compliance with the nondiscrimination clauses
10 of this contract or with any of such rules, regulations, or orders, this contract may
11 be canceled, terminated or suspended in whole or in part and the contractor may be
12 declared ineligible for further Government contracts in accordance with procedures
13 authorized in Executive Order 11246 of September 24, 1965, and such other
14 sanctions may be imposed and remedies invoked as provided in Executive Order
15 11246 of September 24, 1965, or by rule, regulation, or order of the Secretary of
16 Labor, or as otherwise provided by law.

17 (7) the contractor will include the provisions of paragraphs (1) through (7) in every
18 subcontract or purchase order unless exempted by rules, regulations, or orders of
19 the Secretary of Labor issued pursuant to section 204 of Executive Order 11246 of
20 September 24, 1965, so that such provisions will be binding upon each
21 subcontractor or vendor. The contractor will take such action with respect to any
22 subcontract or purchase order as may be directed by the Secretary of Labor as a
23 means of enforcing such provisions including sanctions for noncompliance:
24 Provided, however, that in the event the contractor becomes involved in, or is
25 threatened with, litigation with a subcontractor or vendor as a result of such
26 direction, the contractor may request the United States to enter into such litigation
27 to protect the interests of the United States.”

28 **32.2.** CONTRACTOR further agrees that it will be bound by the above equal opportunity

1 clause with respect to its own employment practices when it participates in federally-
2 assisted construction work; provided that if CONTRACTOR so participating is a State
3 or local government, the above equal opportunity clause is not applicable to any agency,
4 instrumentality, or subdivision of such government which does not participate in work
5 on or under the Agreement.

6 **32.3.** CONTRACTOR agrees that it will assist and cooperate actively with the administering
7 agency and the Secretary of Labor in obtaining the compliance of Contractors and
8 subcontractors with the equal opportunity clause and the rules, regulations, and relevant
9 orders of the Secretary of Labor, that it will furnish the Department and HUD and the
10 Secretary of Labor such information as they may require for the supervision of such
11 compliance, and that it will otherwise assist the administering agency in the discharge
12 of the agency's primary responsibility for securing compliance.

13 **32.4.** CONTRACTOR further agrees that it will refrain from entering into any contract or
14 contract modification subject to Executive Order 11246 of September 24, 1965, with a
15 contractor debarred from, or who has not demonstrated eligibility for, government
16 contracts and federally-assisted construction contracts, pursuant to the Executive Order
17 and will carry out such sanctions and penalties for violation of the equal opportunity
18 clause as may be imposed upon contractors and subcontractors by the administering
19 agency or the Secretary of Labor pursuant to Part II, Subpart D of the Executive Order.
20 In addition, CONTRACTOR agrees that if it fails or refuses to comply with these
21 undertakings, COUNTY may take any or all of the following actions: Cancel,
22 terminate, or suspend in whole or in part this funding commitment (contract, loan,
23 grant, insurance, guarantee); refrain from extending any further assistance to the
24 applicant under the program with respect to which the failure or refund occurred until
25 satisfactory assurance of future compliance has been received from such Contractor;
26 and refer the case to the Department of Justice for appropriate legal proceedings.

27 **33. ASSIGNMENT OF CLAIMS – CLAYTON OR CARTWRIGHT ACTS.**

28 CONTRACTOR shall comply with the following provisions regarding the assignment of claims

1 arising from either the Clayton Act or the Cartwright. For the purposes of this Section, the term
2 “contractor” shall refer to CONTRACTOR, the term “awarding body” shall refer to COUNTY, and the
3 term “public works contract” shall refer to this Agreement:

4 *“In entering into a public works contract or a subcontract to supply goods, services, or materials*
5 *pursuant to a public works contract, the contractor or subcontractor offers and agrees to assign to the*
6 *awarding body all rights, title, and interest in and to all causes of action it may have under Section 4*
7 *of the Clayton Act (15 U.S.C. Sec. 15) or under the Cartwright Act (Chapter 2 (commencing with*
8 *Section 16700) of Part 2 of Division 7 of the Business and Professions Code), arising from purchases*
9 *of goods, services, or materials pursuant to the public works contract or the subcontract. This*
10 *assignment shall be made and become effective at the time the awarding body tenders final payment to*
11 *the contractor, without further acknowledgment by the parties.”*

12 **34. NON-COLLUSION.**

13 CONTRACTOR agrees he/she has executed and submitted with the Bid a Non-Collusion Affidavit
14 that complies with Cal. Public Code §7106, included in **Exhibit “B”** and incorporated herein.

15 **35. NOTICES AND REPORTS.**

16 **35.1.** All notices and reports under this Agreement shall be in writing and may be given by
17 personal delivery or by mailing by certified mail, addressed as follows:

18
19 COUNTY
20 Imperial County Department of Public Works
21 Attention: Director
22 155 South Eleventh Street
23 El Centro, CA 92243

CONTRACTOR
«Contractor_Business_Name»
«Contractor_Street_Address»
«Contractor_City_State»

24 with copies to:

25 Imperial County Executive Office
26 Attention: County Executive Officer
27 940 West Main Street, Suite 208
28 El Centro, CA 92243

and:

1 Imperial County Department of Human
Resources and Risk Management
2 Attention: Director
940 West Main Street, Suite 101
3 El Centro, CA 92243
4

5 **35.2.** Notices and reports under this Agreement may be given by personal delivery or by
6 mailing by certified mail at such other address as either Party may designate in a notice
7 to the other Party given in such manner. Any notice given by mail shall be considered
8 given when deposited in the United States Mail, postage prepaid, addressed as provided
9 herein.

10 **36. ENTIRE AGREEMENT.**

11 This Agreement contains the entire agreement between COUNTY and CONTRACTOR
12 relating to the transactions contemplated hereby and supersedes all prior or contemporaneous
13 agreements, understandings, provisions, negotiations, representations, or statements, either written or
14 verbal.

15 **37. ASSIGNMENT.**

16 Neither this Agreement nor any duties or obligations hereunder shall be assignable by
17 CONTRACTOR without the prior written consent of COUNTY.

18 **38. MODIFICATION.**

19 No modification, waiver, amendment, discharge, or change of this Agreement shall be valid
20 unless the same is in writing and signed by the Party against whom the enforcement of such
21 modification, waiver, amendment, discharge, or change is or may be sought.

22 **39. CAPTIONS.**

23 Captions in this Agreement are inserted for convenience of reference only and do not define,
24 describe or limit the scope or the intent of this Agreement or any of the terms thereof.

25 **40. PARTIAL INVALIDITY.**

26 If any provision in this Agreement is held by a court of competent jurisdiction to be invalid,
27 void, or unenforceable, the remaining provisions will nevertheless continue in full force without being
28 impaired or invalidated in any way.

1 **41. GENDER AND INTERPRETATION OF TERMS AND PROVISIONS.**

2 Words and expressions in the masculine gender include the feminine and neuter genders.
3 Words and expressions in the singular include the plural and words and expressions in the plural
4 include the singular. CONTRACTOR as used in this Agreement or in any other document referred to
5 in or made a part of this Agreement shall likewise include both singular and the plural, a corporation, a
6 partnership, individual, firm or person acting in any fiduciary capacity as executor, administrator,
7 trustee or in any other representative capacity or any other entity. All covenants herein contained on
8 the part of CONTRACTOR shall be joint and several if more than one person, firm or entity executes
9 the Agreement.

10 **42. WAIVER.**

11 No waiver of any breach or of any of the covenants or conditions of this Agreement shall be
12 construed to be a waiver of any other breach or to be consent to any further or succeeding breach of the
13 same or any other covenant or condition.

14 **43. CHOICE OF LAW.**

15 The laws of the State of California shall govern this Agreement. This Agreement is made and
16 entered into in Imperial County, California. Any action brought by either Party with respect to this
17 Agreement shall be brought in a court of competent jurisdiction within said County.

18 **44. AUTHORITY.**

19 **44.1.** Each individual executing this Agreement on behalf of CONTRACTOR represents and
20 warrants that:

21 **44.1.1.** He/She is duly authorized to execute and deliver this Agreement on behalf of
22 CONTRACTOR;

23 **44.1.2.** Such execution and delivery is in accordance with the terms of the Articles of
24 Incorporation or Partnership, any by-laws or Resolutions of CONTRACTOR
25 and;

26 **44.1.3.** This Agreement is binding upon CONTRACTOR in accordance with its terms.

27 **44.2.** CONTRACTOR shall deliver to COUNTY evidence acceptable to COUNTY of the
28 foregoing within thirty days of execution of this Agreement.

1 **45. COUNTERPARTS.**

2 This Agreement and any subsequent modifications may be executed in any number of
3 counterparts, each of which when executed shall be an original, and all of which together shall
4 constitute one and the same Agreement. No counterparts shall be effective until all Parties have
5 executed a counterpart hereof.

6 **46. TIMING.**

7 The Parties agree that time is of the essence in this Agreement.

8 **47. REVIEW OF AGREEMENT TERMS.**

9 **47.1.** Each Party has had the opportunity to receive independent legal advice from its
10 attorneys with respect to the advisability of making the representations, warranties,
11 covenants and agreements provided for herein, and with respect to the advisability of
12 executing this Agreement.

13 **47.2.** Each Party represents and warrants to and covenants with the other Party that:

14 **47.2.1.** This Agreement in its reduction to final written form is a result of extensive
15 good faith negotiations between the Parties and/or their respective legal counsel;
16 and

17 **47.2.2.** The Parties and/or their legal counsel have carefully reviewed and examined this
18 Agreement for execution by said Parties.

19 **47.3.** Any statute or rule of construction that ambiguities are to be resolved against the
20 drafting party shall not be employed in the interpretation of this Agreement.

21 **48. APPENDIX E OF THE TITLE VI ASSURANCES.**

22 During the performance of this contract, the CONTRACTOR, for itself, its assignees, and successors
23 in interest agrees to comply with the following nondiscrimination statutes and authorities; including
24 but not limited to:

25 **48.1.** Pertinent Nondiscrimination Authorities:

26 (a) Title VI of the Civil Rights Act of 1964 (42 U.S.C. § 2000d et seq, 78 stat. 252),
27 (prohibits discrimination on the basis of race, color, national origin); and 49 CFR Part
28 21.

- 1 (b) The Uniform Relocation Assistance and Real Property Acquisition Policies Act of
2 1970, (42 U.S.C. § 4601), (prohibits unfair treatment of persons displaced or whose
3 property has been acquired because of Federal or Federal-Aid programs and projects);
- 4 (c) Federal-Aid Highway Act of 1973, (23 U.S.C. § 324 et seq.), prohibits discrimination
5 on the basis of sex);
- 6 (d) Section 504 of the Rehabilitation Act of 1973, (29 U.S.C. § 794 et seq.) as amended,
7 (prohibits discrimination on the basis of disability); and 49 CFR Part 27;
- 8 (e) The Age Discrimination Act of 1975, as amended, (42 U.S.C. § 6101 et seq.), (prohibits
9 discrimination on the basis of age);
- 10 (f) Airport and Airway Improvement Act of 1982, 949 U.S.C. § 4 71, Section 4 7123), as
11 amended, (prohibits discrimination based on race, creed, color, national origin, or sex);
- 12 (g) The Civil Rights Restoration Act of 1987, (PL 100-209), (Broadened the scope,
13 coverage and applicability of Title VI of the Civil Rights Act of 1964, The Age
14 Discrimination Act of 1975 and Section 504 of the Rehabilitation Act of 1973, by
15 expanding the definition of the terms “programs or activities” to include all the
16 programs or activities of the Federal-aid recipients, subrecipients and contractors,
17 whether such programs or activities are Federally funded or not);
- 18 (h) Titles II and III of the Americans with Disabilities Act, which prohibit discrimination
19 on the basis of disability in the operation of public entities, public and private
20 transportation systems, places of public accommodation, and certain testing entities (42
21 U.S.C. §§ 12131-12189) as implemented by Department of Transportation regulations
22 at 49 C.F.R. parts 37 and 38;
- 23 (i) The Federal Aviation Administration’s Nondiscrimination statute (49 U.S.C. § 47123)
24 (prohibits discrimination on the basis of race, color, national origin, and sex);
- 25 (j) Executive Order 12898, Federal Actions to Address Environmental Justice in Minority
26 Populations and Low-Income Populations, which ensures discrimination against
27 minority populations by discouraging programs, policies, and activities with
28 disproportionately high and adverse human health or environmental effects on minority

1 and low-income populations;

2 (k) Executive Order 13166, Improving Access to Services for persons with Limited English
3 Proficiency, and resulting agency guidance, national origin discrimination includes
4 discrimination because of limited English proficiency (LEP). To ensure compliance
5 with Title VI, you must take reasonable steps to ensure that LEP persons have
6 meaningful access to your programs (70 Fed. Reg. at 74087 to 74100);

7 (l) Title IX of the Education Amendment of 1972, as amended, which prohibits you from
8 discriminating because of sex in education programs or activities (20 U.S.C. 1681 et
9 seq).

10 **IN WITNESS WHEREOF**, the Parties have executed this Agreement on the day and year first
11 above written.

12
13 **County of Imperial**

12
13 **«Contractor_Business_Name»**

14
15
16 By: _____
17 Ryan E. Kelley, Chairman
18 Imperial County Board of Supervisors

14
15
16 By: _____
17 «Contractor_Name_for_Signature»

18
19 **ATTEST:**

20
21 By: _____
22 Blanca Acosta,
23 Clerk of the Board of Supervisors

24 **APPROVED AS TO FORM:**

25 Eric Havens,
26 County Counsel

27 By: _____
28 «CC_Attorney»,
«CC_Attorney_Title»