



**COUNTY OF IMPERIAL  
DEPARTMENT OF PUBLIC WORKS**

155 South 11th Street  
El Centro, CA 92243  
Phone: (442) 265-1818  
Fax: (442) 265-1858

# PROJECT MANUAL

**Imperial County Brawley Road Yard Replacement  
4736 State Hwy-111, Brawley, Ca. 92227**

**COUNTY PROJECT NO. SR5901ADM**



Approved by: JOHN A. GAY, P.E., DIRECTOR OF PUBLIC WORKS

*John A. Gay*  
\_\_\_\_\_  
Signature

*7/12/22*  
\_\_\_\_\_  
Date

Contact person: Kimberly Cortes, Administrative Analyst I

Pre-Bid Mandatory Conference Date: **August 15<sup>th</sup>, 2022**

Bid Opening Date: **September 2<sup>nd</sup>, 2022 at 2:00PM**



# SPECIAL NOTICE

Pursuant to the requirements of Senate Bill 854 and California Labor Code section 1725.5, all contractors and subcontractors that wish to engage in public work through a public works contract must first register with the Department of Industrial Relation and pay all applicable fees.

Beginning March 1, 2015, no contractor or subcontractor may be listed on a bid proposal for a public works project unless registered with the Department of Industrial Relations, pursuant to Labor Code section 1725.5 (with limited exceptions from this requirement for bid purposes only under Labor Code section 1771.1(a)).

Beginning April 1, 2015, no contractor or subcontractor may be awarded a contract for public work on a public works project unless registered with the Department of Industrial Relations, pursuant to Labor Code section 1725.5.

This Project is subject to compliance monitoring and enforcement by the Department of Industrial Relations.

For more information concerning Senate Bill 854 compliance, please visit: <http://www.dir.ca.gov/Public-Works/SB854.html>.

## **PUBLIC WORKS REFORMS (SB 854) FACT SHEET**

Public works reforms (SB 854) were signed into law on June 20, 2014. The reforms made several significant changes to the administration and enforcement of prevailing wage requirements by the Department of Industrial Relations (DIR). Among other things, SB 854 established a public works contractor registration program to replace prior Compliance Monitoring Unit (CMU) and Labor Compliance Program (LCP) requirements for bond-funded and other specified public works projects. The fees collected through the program established by SB 854 are used to fund DIR's public works activities.

### **Essentials of public works contractor registration program:**

- Contractors are subject to a registration and annual renewal fee set at \$400. This fee is non-refundable and applies to all contractors and subcontractors who intend to bid or perform work on public works projects (as defined under the Labor Code).
- Contractors apply and pay the fee online and must meet minimum qualifications to be registered as eligible to bid and work on public works projects:
  - Must have workers' compensation coverage for any employees and only use subcontractors who are registered public works contractors.
  - Must have Contractors State License Board license if applicable to trade.
  - Must not have any delinquent unpaid wage or penalty assessments owed to any employee or enforcement agency.
  - Must not be under federal or state debarment.
  - Must not be in prior violation of this registration requirement once it becomes effective. However, for the first violation in a 12-month period, a contractor may still qualify for registration by paying an additional penalty.
- The registration fee is not related to any project. It is more like a license that enables the registrant to bid on and perform public works.
- DIR provides a searchable database of registered contractors and subcontractors on its website, so that awarding bodies and contractors can comply with the requirement to only use registered contractors and subcontractors.
- Various protections are built in so that
  - A contractor won't be in violation for working on a private job that is later determined to be public work;
  - The inadvertent listing of an unregistered subcontractor on a bid doesn't necessarily invalidate that bid;
  - A contract with an unregistered contractor or subcontractor is subject to cancellation but is not void as to past work;
  - An unregistered contractor or subcontractor can be replaced with one who is registered;
  - A contractor whose registration lapses will have a 90-day grace period within which to pay a late fee and renew.
- Contractors and subcontractors register online. The preferred method of payment is by credit card.
- The requirement to list only registered contractors and subcontractors on bids became effective on March 1, 2015. The requirement to only use registered contractors and subcontractors on public works projects applies to all projects awarded on or after April 1, 2015.

## **Essentials of Public Works Enforcement Fund:**

All contractor registration fees go into the State Public Works Enforcement Fund and are used to fund the following items:

- Administration of contractor registration requirement;
- All DIR costs for administering and enforcing public works laws;
- Labor Commissioner's enforcement of other Labor Code violations on monitored public works projects.

DIR no longer charges awarding bodies for prevailing wage compliance monitoring and enforcement on legacy CMU projects.

## **Related changes in DIR's administration and enforcement of public works requirements:**

- Requirements to use CMU or specified alternative (labor compliance program or project labor agreement) for state bond-funded and other specified projects were eliminated and replaced by requirements that apply to *all* public works projects (as defined under the Labor Code).
- Awarding bodies are required to submit PWC-100 (contract award notice) for all public works projects.
- Contractors and subcontractors on *all* public works projects are required to submit certified payroll records (CPRs) to the Labor Commissioner unless excused from this requirement. -
  - CPRs are furnished to the Labor Commissioner online
  - This requirement phases in as follows:
    - Applied to public works projects that had been under CMU monitoring;
    - Applies to any new projects awarded on or after April 1, 2015;
    - May apply to other projects as determined by Labor Commissioner;
    - Applies to *all* public works projects, (except those listed under Exemptions just below), on and after January 1, 2016.
  - Exemptions: As of April 1, 2015, and even after January 1, 2016, the following projects are exempt from the requirement to have contractors and subcontractors furnish certified payroll records (CPRs) to the Labor Commissioner:

## **Small Project Exemption**

Contractors who work exclusively on small public works projects are not required to register as a public works contractor or file electronic certified payroll reports for those projects. Contractors are still required to maintain certified payroll records on a continuous basis, and provide them to the Labor Commissioner's Office upon request. Additionally, awarding agencies are not required to submit the notice of contract award through DIR's PWC-100 system on projects that fall within the small project exemption. The small project exemption applies for all public works projects that do not exceed:

- \$25,000 for new construction, alteration, installation, demolition or repair
- \$15,000 for maintenance

Any projects monitored and enforced by the following legacy LCPs:

- California Department of Transportation (Caltrans)
- City of Los Angeles
- Los Angeles Unified School District
- County of Sacramento

**Projects covered by qualifying project labor agreements**, at the Labor Commissioner's discretion.

- Requirements for awarding bodies to adopt and enforce a DIR-approved LCP are now limited to: (1) ongoing public works projects awarded prior to January 1, 2012, that were under a pre-existing LCP requirement (see the four legacy LCPs listed above) and (2) projects funded in whole or in part by Proposition 84.

June 2017

**IMPERIAL COUNTY BRAWLEY ROAD YARD REPLACEMENT  
4736 STATE HWY-111, BRAWLEY, CA. 92227**

**COUNTY PROJECT NO. SR5901ADM**

**TABLE OF CONTENTS**

Notice to Contractor Calling for Bids	7
Information for Bidders	13
Bid Form	18
Non-collusion Affidavit to be Executed by Bidder and Submitted with Bid	22
Designation of Subcontractors	23
Public Contract Code Section 10162 Questionnaire	26
Contractor's Certificate Regarding Workers Compensation	28
Bid Bond	29
Performance Bond	31
Payment Bond for Public Works	32
Contents of General Conditions	33
General Conditions	37
Exhibit A – General Notes	73
Exhibit B – Comprehensive Specifications	
Exhibit C – Construction Drawings	
Exhibit D – Sample Agreement for Services	

## NOTICE TO CONTRACTOR CALLING FOR BIDS

NOTICE IS HEREBY GIVEN that the COUNTY OF IMPERIAL, California, acting by and through its Board of Supervisors (hereinafter referred to as "COUNTY"), will receive up to, but not later than 2:00pm on September 2<sup>nd</sup>, 2022, sealed bids for the award of a contract for the proposed project:

**IMPERIAL COUNTY BRAWLEY ROAD YARD REPLACEMENT  
4736 STATE HWY-111, BRAWLEY, CA. 92227  
COUNTY PROJECT NO. SR5901ADM**

The Contractor shall possess a California Contractor's B License at the time this contract is awarded.

Bids shall be received in the office of the Clerk of the Board of Supervisors, 940 Main Street, Suite 209, El Centro, California 92243, and shall be opened publicly and read aloud at the above stated time and place.

Each bid package must conform and be responsive to the contract documents, bid sets are available starting on July 26<sup>th</sup>, 2022 at the following <https://publicworks.imperialcounty.org/projects-out-to-bid/> "Projects out to bid" at no charge and at Public Works, 155 South Eleventh Street, El Centro, CA, 92243, Phone (442) 265-1818, Monday through Thursday 8:00 AM - 5:00 PM (PDT) for a hard copy set for a fee. Those desiring to pick up bid sets shall call to reserve a copy of bid documents to ensure the availability.

A one hundred dollar (\$100) non-refundable fee for each hardcopy bid package set of the contract documents is required.

Only those firms who have purchased the bid documents will be mailed any addendums that may be issued for this project prior to the bid opening date.

Each bid shall be accompanied by the bid security referred to in the contract documents and the list of proposed subcontractors in the form of a certified or cashier check or a bid bond for ten percent (10%) of the maximum bid amount being proposed.

In contracts involving expenditure in excess of ten thousand dollars (\$10,000), the successful bidder shall file a payment bond in a penal sum at least equal to the full contract value as awarded. The bond shall be approved by COUNTY and shall be in the form set forth in the contract documents. The successful bidder shall also file a performance bond in a penal sum at least equal to the full contract value as awarded.

A performance and payment bond must be filed for contracts involving expenditure in excess of twenty-five thousand dollars (\$25,000), and may be required for contracts involving smaller expenditures at the option of COUNTY.

A Contractor's and Subcontractor's Pre-Bid Conference will be held on the following date: August 15<sup>th</sup>, 2022 at 9:00am at:



IMPERIAL COUNTY BRAWLEY ROAD YARD REPLACEMENT  
4736 STATE HWY-111, BRAWLEY, CA. 92227  
COUNTY PROJECT NO. SR5901ADM

Contact Person: Kimberly Cortes, Administrative Analyst I  
Telephone: (442) 265-1818

Attendance at the Pre-Bid Conference and Facility Walkthrough is **MANDATORY AND STRONGLY RECOMMENDED.**

Before submitting a bid, ALL BIDDERS are required to examine the project site and fully inform themselves as to all existing site conditions and limitations. The bid proposal shall include the cost of all items necessary for the construction of the Project. Bidder shall not receive any additional compensation for costs resulting from conditions that Bidder could have discovered with due diligence prior to submitting a bid.

Any potential bidder whom has been deemed ineligible to perform work on public works projects pursuant to Labor Code Sections 1777.1 or 1777.7 shall be prohibited from bidding on, being awarded a contract for, or performing work as a subcontractor on this project, or any other public works project within the state of California.

COUNTY reserves the right to reject any or all bids or to waive any irregularities or informalities in any bids or in the bidding.

All information required by the bid forms must be completely and accurately provided. Numbers shall be stated in both words and figures where so indicated in the bid forms; conflicts between a number stated in words and in figures are governed by the words. Partially completed Bid Proposals, including bid forms with items left blank, or Bid Proposals submitted on other than the bid forms included herein are non-responsive and will be rejected. Bid Proposals not conforming to these instructions for bidders and the Notice to Contractors Calling for Bids may be deemed nonresponsive and rejected.

Pursuant to Section 20103.8 of the Public Contract Code: A local agency may require a bid for a public works contract to include prices for items that may be added to, or deducted from, the scope of work in the contract for which the bid is being submitted. Whenever additive or deductive items are included in a bid, the bid solicitation shall specify which one of the following methods will be used to determine the lowest bid. In the absence of a specification, only the method provided by subdivision (a) will be used:

- (a) The lowest bid shall be the lowest bid price on the base contract without consideration of the prices on the additive or deductive items.

A responsible bidder who submitted the lowest bid as determined by this section shall be awarded the contract, if it is awarded. This section does not preclude the local agency from adding to or deducting from the contract any of the additive or deductive items after the lowest responsible bidder has been determined.

## ENGINEER'S OPINION OF PROBABLE QUANTITY BASE BID

AL = Allowance  
LF = Linear Foot

CF = Cubic Feet  
LS = Lump Sump

CY = Cubic Yard  
SF = Square Feet

EA = Each  
TON = (2,000 lbs)

LB = Pounds

ITEM No.	ITEM DESCRIPTION	UNIT	ESTIMATED QUANTITY
1.	Mobilization/Demobilization, temporary facilities, construction sign, insurance, bonds, taxes, fees and similar expenses		
2.	Materials, devices, equipment and operators required for proper separation, handling, storage, load, transport and disposal of hazardous waste	LS	1
3.	Misc - Site supervision, general conditions, general requirements, documentation	LS	1
4.	Traffic Control – Signs, Barriers, Devices	LS	1
5.	Hazardous Material Response Supervisor (HAZMAT)		
6.	Time and material allocation		
<b>EXCAVATION:</b>			
7.	Site excavation approx.36" below building pad elevation	CY	185
8.	Stockpile and loading	CY	185
9.	Waste profile sampling	LS	1
<b>DISPOSAL:</b>			
10.	Transportation	CY	185
11.	Offsite Disposal	CY	185
12.	Manifest Filing		

Nothing in this section shall preclude the prequalification of subcontractors.

COUNTY hereby affirms and notifies all bidders that it will affirmatively ensure that in any contract entered into pursuant to this advertisement, disadvantaged business enterprises will be afforded full opportunity to submit bids in response to this invitation and will not be discriminated on the grounds of race, sex, color, or national origin in consideration for an award.

Pursuant to section 1773 of the Labor Code, the general prevailing rate of wages in the County in which the work is to be done has been determined by the Director of the California Department of Industrial Relations and are on file and available from the Clerk of the Board of Supervisors located at the County Administration Center, 940 Main Street, El Centro, CA 92243.

The Director of Industrial Relations has determined the general prevailing rate of per diem wages in the locality in which this work is to be performed for each craft or type of worker needed to execute the contract which will be awarded to the successful bidder.

Use the following internet access URL:

[Director's General Prevailing Wage Determinations \(ca.gov\)](http://www.dir.ca.gov)

It shall be mandatory upon the Contractor to whom the contract is awarded, and upon

employed by them in the execution of the contract. No bidder may withdraw their bid for a period of ninety (90) days after the date set for the opening of bids.

Bidders are advised that they may elect to substitute securities for any retention of funds by the County to ensure performance under the Contract. At the request and expense of Bidder, securities equivalent to the amount retained shall be deposited with the County, or with a state or federally chartered bank in this state as the escrow agent, who shall then return the securities to Bidder once the Project has been completed.

Alternatively, the Bidder may request, and the County shall make payment of retentions earned directly to the escrow agent at the expense of the Bidder. The Bidder, at its sole cost and expense, may direct the investment of the payments into securities, and the Bidder shall receive the interest earned on the investments. Once the Project has been completed, the Bidder shall receive from the escrow agent all securities, interest and payments received by the escrow agent from the County.

Securities eligible for investment include those listed in Cal Gov Code § 16430, bank or savings and loan certificates of deposit, interest-bearing demand deposit accounts, standby letters of credit, or any other security mutually agreed to by the County and the Bidder. The Bidder shall be the beneficial owner of any securities substituted for retained funds and shall receive any interest thereon.

Substitution of securities shall be conducted through an Escrow Agreement substantially similar to that found in Cal Pub Contract Code § 22300(f).

PLEASE NOTE: Substitution of securities is prohibited where funding for the Project, in whole or in part, will be provided by the Farmers Home Administration of the United States Department of Agriculture pursuant to the Consolidated Farm and Rural Development Act (7 U.S.C. Sec 1921 et seq.) or where otherwise disallowed by federal law.

  
\_\_\_\_\_  
Blanca Acosta  
Clerk of the Board of Supervisors

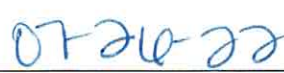
  
\_\_\_\_\_  
Date

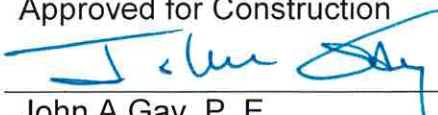
Approved for Construction  
  
\_\_\_\_\_  
John A. Gay, P. E.  
Director of Public Works

  
\_\_\_\_\_  
Date



# VICINITY MAP



IMPERIAL COUNTY PUBLIC WORKS DEPARTMENT  
EL CENTRO, CA

Imperial County Brawley Road Yard Replacement  
4736 State Hwy-111, Brawley, Ca. 92227

County Project No. SR5901ADM

# LOCATION MAP



IMPERIAL COUNTY  
PUBLIC WORKS  
DEPARTMENT  
EL CENTRO, CA

Imperial County Brawley Road Yard Replacement  
4736 State Hwy-111, Brawley, Ca. 92227

County Project No. SR5901ADM



## INFORMATION FOR BIDDERS

1. Preparation of Bid Form. COUNTY invites bids on the form attached to be submitted at such time and place as is stated in the form *Notice to Contractors Calling for Bids*. All blanks in the bid form must be appropriately completed, and all prices must be stated in both words and figures. All bids must be submitted in sealed envelopes bearing on the outside the name of the bidder, the bidder's address, and the name of the project for which the bid is submitted. It is the sole responsibility of the bidder to see that the bid is received by COUNTY prior to the date and time specified for opening bids. Any bid received after the scheduled closing time for receipt of bids will be returned to the bidder unopened.
2. Bid Security. Each bid shall be accompanied by a certified or cashier's check payable to COUNTY or a satisfactory bid bond in favor of COUNTY executed by the bidder as principal and a satisfactory surety company as surety, in an amount not less than ten percent (10%) of the maximum amount of the bid. The check or bid bond shall be given as guarantee that the bidder shall execute the contract if it be awarded to it in conformity with the contract documents and shall provide the surety bond or bonds as specified therein within ten (10) days after notification of the award of the contract to the bidder.
3. Signature. The bid must be signed in the name of the bidder and must bear the signature in longhand of the person or persons duly authorized to sign the bid.
4. Modifications. Changes in or additions to the bid form, recapitulations of the work bid upon, alternative proposals, or any other modification of the bid form which is not specifically called for in the contract documents may result in COUNTY's rejection of the bid as not being responsive to the invitation to bid. No oral or telephonic modification may be considered.

Any proposed modifications of a bidder's bid must be in writing and received by COUNTY prior to the date and time specified for opening bids.

5. Erasures. The bid submitted must not contain any erasures, interlineations, or other corrections unless each such correction is suitably authenticated by affixing in the margin immediately opposite the correction and the surname, or surnames of the person or persons signing the bid.
6. Examination of Site and Contract Documents. Each bidder shall visit the site of the proposed work and fully acquaint itself with the conditions relating to the construction and labor so that it may fully understand the facilities, difficulties and restrictions attending the execution of the work under the contract. Bidders shall thoroughly examine and be familiar with the drawings and specifications. The failure or omission of any bidder to receive or examine any contract documents, form, instrument, addendum or other document, or to visit the site and acquaint itself with conditions there existing, shall in no way relieve any bidder from obligations with respect to its bid or to the contract. The submission of a bid shall be taken as *prima facie* evidence of compliance with this section.



7. Withdrawal of Bids. Any bidder may withdraw its bid either personally, by written request, or by telegraphic request confirmed in the manner specified above at any time prior to the scheduled closing time for receipt of bids.
8. Relief from Mistake in Bid. The attention of bidders is called to Public Contracts Code sections 5100 to 5104, particularly the requirements of section 5103 which requires that grounds for relief from a mistaken bid require written notice to the public entity within five (5) working days after the opening of the bids of mistake and such notice shall detail how the mistake occurred. Please note that a bidder shall not be relieved of its bid unless the elements of Public Contract Code section 5103 are met and the written consent of COUNTY is obtained and/or by order of a court of competent jurisdiction.
9. Agreements and Bonds. The agreement form which the successful bidder, as Contractor, will be required to execute, and the forms and amounts of the surety bonds which it will be required to furnish at the time of execution of the agreements, are included in the contract documents and should be carefully examined by the bidder. The required number of executed copies of the *Agreement*, the *Performance Bond*, and the *Payment Bond* for County Projects is as specified in the *Special Conditions*.
10. Interpretation of Plans and Documents. If any person contemplating submitting a bid for the proposed contract is in doubt as to the true meaning of any part of the drawings, specifications or other contract documents, or finds discrepancies in or omissions from the drawings and specifications, he or she shall submit to COUNTY a written request for an interpretation or correction thereof no less than ten (10) days prior to the bid opening. The person submitting the request will be responsible for its prompt delivery. Any interpretations or correction of the contract documents will be made only by addendum duly issued, and a copy of such addendum will be mailed or delivered to each person receiving a set of the contract documents. No oral interpretation of any provision in the contract documents will be made to any bidder. The interpretation of Plans and documents upon bid award shall be addressed in accordance with Article 2 of the "General Conditions."
11. Bidders Interested in More Than One Bid. No person, firm, or corporation shall be allowed to make, or file, or be interested in more than one bid for the same work unless alternate bids are specifically called for. A person, firm, or corporation that has submitted a sub-proposal to a bidder, or that has quoted prices of materials to a bidder, is not thereby disqualified from submitting a sub-proposal or quoting prices to other bidders or make a prime proposal.
12. Award of Contract. COUNTY reserves the right to reject any or all bids, or to waive any irregularities or informalities in any bids or in the bidding. The award of the contract, if made by COUNTY, will be to the lowest responsible bidder therefore. Award of the contract may be on October, 2022 (tentative), and an Agreement shall be presented to the successful bidder at that time. Successful bidder shall then have ten (10) days to execute the Agreement and provide all payment and performance bonds required for this project. Please note that a posted tabulation may be a preliminary tabulation which has not been reviewed for responsiveness and

responsibility. It is possible that the lowest bidder will not be awarded the contract because of non-responsiveness or non-responsibility.

13. Alternates. If alternate bids are called for, the contract may be awarded at the election of the governing board to the lowest responsible bidder on the base bid, or on the base bid and any alternate or combination of alternates.
14. Bidder Contact Information. The bidder shall submit complete name, address and phone listings, (including fax), and contact person at bidder's company, provide a complete list of all personnel, subcontractors, and other agencies that will be assigned to this project and the responsibility that each will have.
15. Listing Subcontractors. Each bidder shall submit with its sealed bid a list of the proposed subcontractors on this project as required by the Subletting and Subcontracting Fair Practices Act (Pub. Cont. Code, § 4100, et seq.). Forms for this purpose are furnished with the contract documents.
16. Workers Compensation and Prevailing Wage Compliance.
  - 16.1. Workers Compensation. In accordance with the provisions of Labor Code section 3700 *et. seq.* Contractor shall secure the payment of compensation to its employees. Contractor shall sign and file with COUNTY the following certificates prior to performing the work under this contract: "I am aware of the provisions of section 3700 of Labor Code which require every employer to be insured against liability for workers compensation or to undertake self-insurance in accordance with the provisions of that code, and I will comply with such provisions before commencing the performance of the work of this contract." The form of such certificate is included as a part of the contract documents.
  - 16.2. Prevailing Wage Compliance. Contractor and its subcontractors shall pay all workers employed on the Project the rates determined by the Director of the California Department of Industrial Relations (DIR). Copies of the State prevailing rate of per diem wages are on file with the Department of Industrial Relations, Division of Apprenticeship Standards, 445 Golden Gate Avenue, San Francisco, California, and at COUNTY's Department of Public Works, and are available to Contractor and any other interested party upon request. Contractor shall post the prevailing rate of per diem wages to be posted at the Project site.
  - 16.3. For those Projects subject to Department of Industrial Relations (DIR) Monitoring and Enforcement, be advised that the Contractor is responsible for submitting certified payroll records directly to the State Compliance Monitoring Unit (CMU). CMU is a new component within the State Division of Labor Standards Enforcement (DLSE) that was created to monitor and enforce prevailing wage requirements on public works projects that receive state bond funding and on other projects that are legally required to use the CMU. The CMU began operations on January 1, 2012, following the recent adoption of AB 436 and approval of revisions to program regulations. By actively monitoring compliance on an ongoing basis while work is being performed, the

CMU will play a special role in ensuring that public works construction workers are promptly paid the proper prevailing wage rates and in helping maintain a level playing field for contractors who comply with the law.

**Effective Date and Applicability:** The laws and regulations that govern the new program are effective January 1, 2012. Only projects for which the public works contract is awarded on or after January 1, 2012 are subject to the CMU requirements. For further information concerning compliance monitoring please visit the website located at: <https://www.dir.ca.gov/Public-Works/publicworks.html>.

17. Substitution of Security. Contractors may substitute securities in place of retained funds withheld by COUNTY in accordance with the provisions of Cal. Pub. Contract Code Section 22300.

18. Contractor's Pre-Bid Conference.

18.1. A Pre-Bid Conference will be held on the following date: **August 15<sup>th</sup>, 2022 at 09:00 a.m.** at:

**IMPERIAL COUNTY BRAWLEY ROAD YARD REPLACEMENT  
4736 STATE HWY-111, BRAWLEY, CA. 92227  
COUNTY PROJECT NO. SR5901ADM**

Contact Person: Kimberly Cortes, Administrative Analyst I  
Telephone: (442) 265-1818

18.2. Attendance at the Pre-Bid Conference and Walkthrough is MANDATORY AND STRONGLY RECOMMENDED.

18.3. Before submitting a bid, ALL BIDDERS are required to examine the project site and fully inform themselves as to all existing site conditions and limitations. The bid proposal shall include the cost of all items necessary for the construction of the Project. Bidder shall not receive any additional compensation for costs resulting from conditions that Bidder could have discovered with due diligence prior to submitting a bid.

18.4. In accordance with Paragraph 10 of the Information for Bidders, any questions to be presented at the Pre-Bid Conference must be in writing and received by COUNTY from General Contractor or subcontractor submitting a Bid on or before September 2<sup>nd</sup>, 2022 at 4:00pm in the Public Works office located at 155 South Eleventh Street, El Centro, California, 92243.

19. Calendar of Events.

1.	Bid packages available	<u>July 26<sup>th</sup>, 2022</u>
2.	<u>MANDATORY</u> Pre-Bid Conference and Facility Walkthrough	<u>August 15<sup>th</sup>, 2022 at 9:00am</u>

3.	Return of Written Plans, Document Questions, and Substitution Requests. <u>Please be advised that Substitution Requests submitted after the due date may render this bid unresponsive.</u>	<u>August 19<sup>th</sup>, 2022 at 4:00pm</u>
4.	Bid package, inclusive of completed bid forms, and bid bond required to be submitted hereunder must be received by COUNTY on or before at: Clerk of the Board 940 Main Street, Suite 209 El Centro, CA 92243 Phone: (760) 482- 4220	<u>September 02, 2022 at 2:00pm</u>
5.	Bid Opening in Board Chambers	<u>September 02, 2022 at 2:00pm</u>
6.	Board of Supervisors review and consideration of award on approximately	<u>September, 2022 (Tentative)</u>
7.	Execution of Contract	<u>October, 2022 (Tentative)</u>
8.	Commencement of construction on or before	<u>October, 2022 (Tentative)</u>
9.	Completion of construction on or before	<u>November 2022 (Tentative)</u>

## BID FORM

TO: Acting by and through its Board of Supervisors, hereinafter called COUNTY.

1. Pursuant to and in compliance with your *Notice to Contractors Calling for Bids* and the other documents relating thereto, the undersigned bidder, having familiarized itself with the terms of the contract, the local conditions affecting the performance of the contract, and the cost of the work at the place where the work is to be done, and with the drawings and specifications and other contract documents, hereby proposes and agrees to perform, within the time stipulated by the contract, including all of its component parts and everything required to be performed, and to provide and furnish any and all of the labor, materials, tools, expendable equipment and all utility and transportation services necessary to perform the contract and complete it in a workmanlike manner, all of the work required in connection with the

**IMPERIAL COUNTY BRAWLEY ROAD YARD REPLACEMENT**  
**4736 STATE HWY-111, BRAWLEY, CA. 92227**  
**COUNTY PROJECT NO. SR5901ADM**

All in strict conformity with the drawings and specifications and other contract documents, including addenda nos., \_\_\_\_\_, \_\_\_\_\_, \_\_\_\_\_, and \_\_\_\_\_, on file at the office of Public Works Facilities Management, for the total sum of \_\_\_\_\_ Dollars (\$\_\_\_\_\_), hereinafter called the *Base Bid Price*.

Warning - If an addendum or addenda have been issued by the Department and not noted above as being received by the bidder, this proposal may be rejected.

COUNTY reserves the right to make award or any combination of base bid process plus deductive bid items as COUNTY determines to be in its best interest.

AL = Allowance      CF = Cubic Feet      CY = Cubic Yard      EA = Each      LB = Pounds  
 LF = Linear Foot      LS = Lump Sump      SF = Square Feet      TON = (2,000 lbs)

ITEM No.	ITEM DESCRIPTION	UNIT	EST. QTY	UNIT PRICE	TOTAL
1.	Mobilization/Domobilization, temporary facilities, construction sign, insurance, bonds, taxes, fees and similar expenses				
2.	Materials, devices, equipment and operators required for proper separation, handling, storage, load, transport and disposal of hazardous waste	LS	1		
3.	Misc- Site supervision, general conditions, general requirements, documentation	LS	1		
4.	Traffic Control – signs, barriers, devices	LS	1		
5.	Hazardous Material Response Supervisor (HAZMAT)				
6.	Time and material allocation				
<b>EXCAVATION:</b>					

7.	Site excavation approx.36" below building pad elevation	CY	185		
8.	Stockpile and loading	CY	185		
9.	Waste profile sampling	LS	1		
<b>DISPOSAL:</b>					
10.	Transportation	CY	185		
11.	Offsite disposal	CY	185		
12.	Manifest filing				

**TOTAL BASE BID: \$** \_\_\_\_\_

*Note: The amount entered as the "Total Base Bid" should be identical to the Base Bid amount entered in Section 1 of the Bid Proposal form.*

**Warning** - If an addendum or addenda have been issued by the Department and not noted above as being received by the bidder, this proposal may be rejected.

COUNTY reserves the right to make award or any combination of base bid process plus deductive bid items as COUNTY determines to be in its best interest.

2. It is understood that COUNTY reserves the right to reject this bid and that this bid shall remain open and not be withdrawn for the period specified in the Notice to Contractors Calling for Bids.

3. The required bid security is hereto attached.

4. The required list of proposed subcontractors is attached hereto.

5. It is understood and agreed that if written notice of the acceptance of this bid is mailed, telegraphed, or delivered to the undersigned after the opening of the bid, and within the time this bid is required to remain open, or at any time thereafter before this bid is withdrawn, the undersigned will execute and deliver to COUNTY a contract in the form attached hereto in accordance with the bid as accepted, and that it will also furnish and deliver to COUNTY the Performance Bond and Payment Bond for the Public Works as specified, all within ten (10) days after receipt of notification of award, and that the work under the contract shall be commenced by the undersigned bidder, if awarded the Contractor, on the date to be stated in COUNTY's Notice to Contractors to Proceed, and shall be completed by the Contractor in the time specified in the contract documents.

6. Notice of acceptance or requests for additional information should be addressed to the undersigned at the address identified in Paragraph 8 below.

7. Print/type the names of all persons interested in the foregoing proposal as principals in the space provided below:

---



---



---



(IMPORTANT NOTICE: If bidder or other interested person is a corporation, state legal name of corporation, also names of the president, secretary, treasurer, and manager thereof; if a co-partnership, state true name of firm, also names of all individual co-partners composing firm; if bidder or other interested person is an individual, state first and last names in full.)

8. Licensed in accordance with act providing for the registration of Contractors:

Company Name: \_\_\_\_\_  
Company Address: \_\_\_\_\_  
Contact Name: \_\_\_\_\_  
Contact Email #: \_\_\_\_\_  
Phone #: \_\_\_\_\_  
License #: \_\_\_\_\_ Expiration Date: \_\_\_\_\_  
Classification (s): \_\_\_\_\_  
DIR Registration #: \_\_\_\_\_ Expiration Date: \_\_\_\_\_  
Gross Annual Receipts for the Firm: \_\_\_\_\_  
Years in Business: \_\_\_\_\_  
Age of Firm: \_\_\_\_\_

9. The undersigned certifies that he/she is now licensed in the appropriate trade in accordance with the provisions of the Contractor's License Law of the State of California, and the number of said license is \_\_\_\_\_ and that said license expires \_\_\_\_\_, 20\_\_\_\_.

10. By my signature on this proposal I certify, under penalty or perjury under the laws of the State of California, that the foregoing questionnaire and statements of Public Contract Code sections 10162, 10232 and 10285.1 are true and correct and that the bidder has complied with the requirements of section 8103 of the Fair Employment and Housing Commission Regulations (Chapter 5, Title 2 of the California Administrative Code). By my signature on this proposal I further certify, under penalty or perjury under the laws of the State of California and the United States of America, that the Non-collusion Affidavit required by Title 23 United States Code, section 112 and Public Contract Code section 7106; and the Title 49 Code of Federal Regulations, Part 29 Debarment and Suspension Certification are true and correct.

Date: \_\_\_\_\_

By: \_\_\_\_\_

Proper Name of Bidder

(Signature of bidder)

(Print/type signator's name)

---

(Print/type title)

NOTE: If bidder is a corporation, the legal name of the corporation shall be set forth above, together with the signatures of authorized officers or agents, and the document shall bear the corporate seal; if bidder is a partnership, the true name of the firm shall be set forth above, together with the signature of the partner or partners authorized to sign contracts on behalf of the partnership; and if bidder is an individual, his/her signature shall be placed above.

Business Address:

Place of Residence:

Telephone:

Fax Number:

**NON-COLLUSION AFFIDAVIT TO BE EXECUTED  
BY BIDDER AND SUBMITTED WITH BID**

State of California

County of Imperial

\_\_\_\_\_ [name of individual], being first duly sworn,  
deposes and says that he or she is \_\_\_\_\_ [title of individual] of  
\_\_\_\_\_ [name of business] the party making the  
foregoing bid that the bid is not made in the interest of, or on behalf of, any undisclosed  
person, partnership, company, association, organization, or corporation; that the bid is  
genuine and not collusive or sham; that the bidder has not directly or indirectly induced or  
solicited any other bidder to put in a false or sham bid, and has not directly or indirectly  
colluded, conspired, connived, or agreed with any bidder or anyone else to put in a sham bid,  
or that anyone shall refrain from bidding; that the bidder has not in any manner, directly or  
indirectly, sought by agreement, communication, or conference with anyone to fix the bid  
price of the bidder or any other bidder, or to fix any overhead, profit, or cost element of the  
bid price, or of that of any other bidder, or to secure any advantage against the public body  
awarding the contract of anyone interested in the proposed contract; that all statements  
contained in the bid are true; and, further, that the bidder has not, directly or indirectly,  
submitted his or her bid price or any breakdown thereof, or the contents thereof, or divulged  
information or data relative thereto, or paid, and will not pay, any fee to any corporation,  
partnership, company association, bid depository, or to any member or agent thereof to  
effectuate a collusive or sham bid.

\_\_\_\_\_  
Signature

## DESIGNATION OF SUBCONTRACTORS

In compliance with the Subletting and Subcontracting Fair Practices Act (Ch. 4 (commencing at section 4100), Div. 2, part 1 of the Cal. Pub. Cont. Code) and any amendments thereof, each bidder shall set forth below:

(a) (1) The name, the location of the place of business, the California contractor license number, and public works contractor registration number issued pursuant to Section 1725.5 of the Labor Code of each subcontractor who will perform work or labor or render service to the prime contractor in or about the construction of the work or improvement, or a subcontractor licensed by the State of California who, under subcontract to the prime contractor, specially fabricates and installs a portion of the work or improvement according to detailed drawings contained in the plans and specifications, in an amount in excess of one-half of 1 percent of the prime contractor's total bid or, in the case of bids or offers for the construction of streets or highways, including bridges, in excess of one-half of 1 percent of the prime contractor's total bid or ten thousand dollars (\$10,000), whichever is greater.

(b) the portion of the work which will be done by each subcontractor under this act. The prime Contractor shall list only one subcontractor for each such portion as is defined by the prime Contractor in this bid.

If a prime contractor fails to specify a subcontractor or if a prime contractor specifies more than one subcontractor for the same portion of work to be performed under the contract in excess of one-half of 1 percent of the prime contractor's total bid, the prime contractor agrees that he or she is fully qualified to perform that portion himself or herself, and that the prime contractor shall perform that portion itself.

No prime Contractor whose bid is accepted shall (a) substitute any subcontractor, (b) permit any subcontractor to be voluntarily assigned or transferred or allow it to be performed by anyone other than the original subcontractor listed in the original bid, or (c) sublet or subcontract any portion of the work in excess of one-half of one percent (1/2%) of 1 percent of the prime Contractor's total bid as to which his original bid did not designate a subcontractor, except as authorized in *Subletting and Subcontracting Fair Practices Act*.

Subletting or subcontracting of any portion of the work in excess of one-half of one percent (1/2%) of 1 percent of the prime Contractor's total bid as to which no subcontractor was designated in the original bid shall only be permitted in cases of public emergency or necessity, and then only after a finding reduced to writing as a public record of the authority awarding this contract setting forth the facts constituting the emergency or necessity.

If all work is to be done without subcontractors, write "None" in the following space:

## SUBCONTRACTOR LIST

For each Subcontractor that will perform a portion of the Work in an amount in excess of one-half of 1% of the Bidder's total contract Price, the bidder must list a description of the Work, the name of the Subcontractor, its California contractor license number, the location of its place of business, its DIR registration number, and the portion of the Work that the Subcontractor is performing based on a percentage of the Base Bid price.

TYPE OF WORK SUBCONTRACTOR WILL DO	NAME UNDER WHICH SUBCONTRACTOR IS LICENSED	CALIFORNIA CONTRACTOR LICENSE NO.	ADDRESS	DIR REG. NO.	PERCENT OF WORK

## SUPPLIERS

NAME OF SUPPLIER	ADDRESS & TELEPHONE No.	TYPE OF MATERIAL

---

(Proper Name of Bidder)

By: 

---

  
(Signature of bidder)

---

(Print/type signator's name)

---

(Print/type title)



## PUBLIC CONTRACT CODE SECTION 10162 QUESTIONNAIRE

In accordance with Public Contract Code section 10162, the Bidder shall complete, under penalty of perjury, the following questionnaire:

Has the bidder, any officer of the bidder, or any employee of the bidder who has a proprietary interest in the bidder, ever been disqualified, removed or otherwise prevented from bidding on, or completing a federal, state or local government project because of a violation of law or a safety regulation?

Yes \_\_\_\_\_ No \_\_\_\_\_

If the answer is yes, explain the circumstances in the following space.

## PUBLIC CONTRACT SECTION 10232 STATEMENT

In accordance with Public Contract Code section 10232, the Contractor hereby states, under penalty of perjury, that no more than one final unappealable finding of contempt of court by a federal court has been issued against the Contractor within the immediately preceding two year period because of the Contractor's failure to comply with an order of a federal court which orders the Contractor to comply with an order of the National Labor Relations Board.

## TITLE 23, UNITED STATES CODE, SECTION 112 NON-COLLUSION AFFIDAVIT

In accordance with Title 23, United States Code, section 112, the bidder hereby states under penalty of perjury, that he has not, either directly or indirectly, entered into any agreement, participated in any collusion, or otherwise taken any action in restraint of free competitive bidding in connection with this contract.

Note: The above Statement questionnaire, and Non-Collusion Affidavit are part of the Proposal. Signing this Proposal on the signature portion thereof shall also constitute Signature of this Statement, Questionnaire, and Non-Collusion Affidavit.

Bidders are cautioned that making a false certification may subject the certifier to criminal prosecution.

## PUBLIC CONTRACT CODE SECTION 10285.1 STATEMENT

In accordance with Public Contract Code section 10285.1 (Chapter 376, Stat. 1985), the bidder hereby declares under penalty of perjury under the laws of the State of California that the bidder has \_\_\_\_\_, has not \_\_\_\_\_ been convicted within the preceding three (3) years of any offenses referred to in that section, including any charge of fraud, bribery, collusion, conspiracy, or any other act in violation of any state or federal antitrust law in connection with the bidding upon, award of, or performance of, any public works contract, as defined in Public Contract Code section 1101, with any public entity, as defined in Public Contract Code section 1100, including the Regents of the University of California or the Trustees of the

California State University. The term "bidder" is understood to include any partner, member, officer, director, responsible managing officer, or responsible managing employee thereof, as referred to in section 10285.1

NOTE: THE BIDDER MUST PLACE A CHECK MARK AFTER "HAS" or "HAS NOT" IN ONE OF THE BLANK SPACES PROVIDED.

THE ABOVE STATEMENT IS PART OF THE PROPOSAL. SIGNING THIS PROPOSAL ON THE SIGNATURE PORTION THEREOF SHALL ALSO CONSTITUTE SIGNATURE OF THIS STATEMENT.

BIDDERS ARE CAUTIONED THAT MAKING A FALSE CERTIFICATION MAY SUBJECT THE CERTIFIER TO CRIMINAL PROSECUTION.

## CONTRACTOR'S CERTIFICATE REGARDING WORKERS COMPENSATION

Labor Code section 3700 in relevant part provides:

"Every employer except the State shall secure the payment of compensation in one or more of the following ways:

- (a) By being insured against liability to pay compensation in one or more insurers duly authorized to write compensation insurance in this State.
- (b) By securing from the Director of Industrial Relations a *Certificate of Consent to Self-Insure*, either as an individual employer, or as one employer in a group of employers, which may be given upon furnishing proof satisfactory to the Director of Industrial Relations of ability to be self-insured and to pay any compensation that may become due to his or her employees."

I am aware of the provisions of section 3700 of the Labor Code which require every employer to be insured against liability for workers compensation or to undertake self-insurance in accordance with the provisions of that Code, and I will comply with such provisions before commencing the performance of the work of this contract.

\_\_\_\_\_  
(Proper Name of Bidder)

By:

\_\_\_\_\_  
(Signature of bidder)

\_\_\_\_\_  
(Print/type signator's name)

\_\_\_\_\_  
(Print/type title)

(In accordance with Article 5 (commencing at section 1860), Chapter 1, Part 7, Division 2 of the Labor Code, the above certificate must be signed and filed with the awarding body prior to performing any work under this contract.)

## BID BOND

KNOW ALL MEN BY THESE PRESENTS, that we \_\_\_\_\_ as Principal, and \_\_\_\_\_ as Surety, are held and firmly bound unto the County, hereinafter called COUNTY, in the penal sum of TEN PERCENT (10%) OF THE TOTAL AMOUNT OF THE BID of the Principal submitted to COUNTY for the work described below for the payment of which sum in lawful money of the United States, well and truly to be made, we bind ourselves, our heirs, executors, administrators, successors and assigns, jointly and severally, firmly by these presents.

THE CONDITION OF THIS OBLIGATION IS SUCH that whereas the Principal has submitted the accompanying bid dated \_\_\_\_\_, 20 \_\_\_\_\_, for

IMPERIAL COUNTY BRAWLEY ROAD YARD REPLACEMENT  
4736 STATE HWY-111, BRAWLEY, CA. 92227  
COUNTY PROJECT NO. SR5901ADM

NOW, THEREFORE, if the Principal shall not withdraw said bid within the period specified therein after the opening of the same, or, if no period be specified, within ninety (90) days after said opening, and if the Principal is awarded the contract, and shall within the period specified therefore, or, if no period be specified, within five (5) days after the prescribed forms are presented to it for signature, enter into the written contract with COUNTY in accordance with the bid as accepted and give bond with good and sufficient surety or sureties, as may be required, for the faithful performance and proper fulfillment of such contract and for the payment for labor and materials used for the performance of the contract, or in the event of the withdrawal of said bid within the period specified or the failure to enter into such contract and give such bonds within the time specified, if the Principal shall pay COUNTY the difference between the amount specified in said bid and the amount for which COUNTY may procure the required work and/or supplies, if the latter amount be in excess of the former; together with all costs incurred by COUNTY in again calling for bids, then the above obligation shall be void and of no effect, otherwise to remain in full force and virtue.

Surety, for value received, hereby stipulates and agrees that no change, extension of time, alterations or addition to the terms of the contract on the call for bids, or to the work to be performed thereunder, or the specifications accompanying the same, shall in anywise affect its obligation under this bond, and it does hereby waive notice of any such change, extension of time, alteration or addition to the terms of said contract or the call for bids, or to the work, or to the specifications.

In the event suit is brought upon this bond by COUNTY and judgment is recovered, Surety shall pay all costs incurred by COUNTY in such suit, including reasonable attorneys' fees to be fixed by the Court.

IN WITNESS WHEREOF, the above-bound parties have executed this instrument under their several seals this \_\_\_\_\_ day of \_\_\_\_\_, 20 \_\_\_\_\_, the name and corporate seal of each corporate party being hereto affixed, and these presents duly signed by its undersigned representative, pursuant to authority of its governing body.

(Corporate Seal)

\_\_\_\_\_  
(Proper Name of Principal)

By:

\_\_\_\_\_  
(Signature)

\_\_\_\_\_  
(Print/type signator's name)

\_\_\_\_\_  
(Print/type title)

(Corporate Seal)

\_\_\_\_\_  
(Proper Name of Surety)

By:

\_\_\_\_\_  
(Signature)

\_\_\_\_\_  
(Print/type signator's name)

\_\_\_\_\_  
(Print/type title)

(Attached Attorney-In-Fact Certificate)

## PERFORMANCE BOND

Whereas, The Board of Supervisors of the County of Imperial, State of California, and \_\_\_\_\_, (hereinafter designated as "principal") have entered into an agreement whereby principal agrees to install and complete certain designated public improvements, which said agreement, dated \_\_\_\_\_, 20\_\_\_\_, and identified as project IMPERIAL COUNTY BRAWLEY ROAD YARD REPLACEMENT 4736 STATE HWY-111, BRAWLEY, CA. 92227. COUNTY PROJECT NO. SR5901ADM, is hereby referred to and made a part hereof; and

Whereas, Said principal is required under the terms of said agreement to furnish a bond for the faithful performance of said agreement.

Now, therefore, we, the principal and \_\_\_\_\_ (hereinafter designated as "surety"), are held and firmly bound unto the County of Imperial (hereinafter designated as "County") in the penal sum of \_\_\_\_\_ dollars (\$\_\_\_\_\_) lawful money of the United States, for the payment of which sum well and truly to be made, we bind ourselves, our heirs, successors, executors and administrators, jointly and severally, firmly by these presents.

The condition of this obligation is such that if the above-bounded principal, his or its heirs, executors, administrators, successors or assigns, shall in all things stand to and abide by, and well and truly keep and perform the covenants, conditions and provisions in the said agreement and any alteration thereof made as therein provided, on his or their part, to be kept and performed at the time and in the manner therein specified, and in all respects according to their true intent and meaning, and shall indemnify and save harmless County, its officers, agents and employees, as therein stipulated, then this obligation shall become null and void; otherwise it shall be and remain in full force and effect.

As a part of the obligation secured hereby and in addition to the face amount specified therefore, there shall be included costs and reasonable expenses and fees, including reasonable attorneys' fees, incurred by County in successfully enforcing such obligation, all to be taxed as costs and included in any judgment rendered.

The surety hereby stipulates and agrees that no change, extension of time, alteration or addition to the terms of the agreement or to the work to be performed thereunder or the specifications accompanying the same shall in anywise affect its obligations on this bond, and it does hereby waive notice of any such change, extension of time, alteration or addition to the terms of the agreement or to the work or to the specifications.

In witness whereof, this instrument has been duly executed by the principal and surety above named, on \_\_\_\_\_, 20\_\_\_\_\_.

---

Principal

By:

---

Surety

By:

[Attach Required Acknowledgment]

---

Attorney-In-Fact

## PAYMENT BOND

Whereas, The Board of Supervisors of the County of Imperial, State of California, and \_\_\_\_\_ hereinafter designated as "the principal") have entered into an agreement whereby the principal agrees to install and complete certain designated public improvements, which agreement, dated \_\_\_\_\_, 20\_\_\_\_, and identified as project IMPERIAL COUNTY BRAWLEY ROAD YARD REPLACEMENT 4736 STATE HWY-111, BRAWLEY, CA. 92227, COUNTY PROJECT NO. SR5901ADM, is hereby referred to and made a part hereof; and

Whereas, Under the terms of the agreement, the principal is required before entering upon the performance of the work, to file a good and sufficient payment bond with the County of Imperial to secure the claims to which reference is made in Title 3 (commencing with section 9000) of Part 6 of Division 4 of the Civil Code.

Now, therefore, the principal and the undersigned as corporate surety, are held firmly bound unto the County of Imperial and all contractors, subcontractors, laborers, material suppliers, and other persons employed in the performance of the agreement and referred to in Title 3 (commencing with section 9000) of Part 6 of Division 4 of the Civil Code in the sum of \_\_\_\_\_ dollars (\$ \_\_\_\_\_), for materials furnished or labor thereon of any kind, or for amounts due under the Unemployment Insurance Act with respect to this work or labor, that the surety will pay the same in an amount not exceeding the amount hereinabove set forth, and also in case suit is brought upon this bond, will pay, in addition to the face amount thereof, costs and reasonable expenses and fees, including reasonable attorneys' fees, incurred by the County of Imperial in successfully enforcing this obligation, to be awarded and fixed by the court, and to be taxed as costs and to be included in the judgment therein rendered.

It is hereby expressly stipulated and agreed that this bond shall inure to the benefit of any and all persons, companies, and corporations entitled to file claims under Title 3 (commencing with section 9000) of Part 6 of Division 4 of the Civil Code, so as to give a right of action to them or their assigns in any suit brought upon this bond.

Should the condition of this bond be fully performed, then this obligation shall become null and void, otherwise it shall be and remain in full force and effect.

The surety hereby stipulates and agrees that no change, extension of time, alteration, or addition to the terms of the agreement or the specifications accompanying the same shall in any manner affect its obligations on this bond, and it does hereby waive notice of any such change, extension, alteration, or addition.

In witness whereof, this instrument has been duly executed by the principal and surety above named, on \_\_\_\_\_, 20\_\_\_\_\_.



\_\_\_\_\_  
Principal

By: \_\_\_\_\_

\_\_\_\_\_  
Surety

By: \_\_\_\_\_

[Attach Required Acknowledgment]

\_\_\_\_\_  
Attorney-In-Fact

## CONTENTS OF GENERAL CONDITIONS

Article 1.	Definitions	36
Article 2.	Drawings and Specifications	36
Article 3.	Copies Furnished	36
Article 4.	Ownership of Drawings	37
Article 5.	Detail Drawings and Instructions	37
Article 6.	Time for Completion and Damages for Delay	37
Article 7.	Progress Schedule	37
Article 8.	Contract Security	37
Article 9.	Assignment	38
Article 10.	Prohibited Interests	38
Article 11.	Separate Contracts	38
Article 12.	Subcontracting	39
Article 13.	Defaults & Remedies	39
Article 14.	Warranties	41
Article 15.	Notices and Reports	42
Article 16.	Workers	42
Article 17.	Prevailing Wages & Payroll Records	43
Article 18.	Apprentices	44
Article 19.	Hours of Work	45
Article 20.	Insurance Coverages	45
Article 21.	Special Insurance Requirements	45
Article 22.	Insurance Endorsements, Clauses & Information	46
Article 23.	Proof of Insurance	47
Article 24.	Choice of Law	47
Article 25.	Permits and Licenses	47
Article 26.	Easements	47
Article 27.	Surveys	48
Article 28.	Excise Taxes	48
Article 29.	Patents and Royalties	48
Article 30.	Materials	48
Article 31.	Substitutions	49
Article 32.	Shop Drawings	49
Article 33.	Samples	50
Article 34.	Cost Breakdown and Periodical Estimates	50
Article 35.	Payments	50
Article 36.	Payment Withheld	51
Article 37.	Changes and Extra Work	52
Article 38.	Deductions for Uncorrected Work	53

Article 39.	Payments by Contractor	53
Article 40.	Contractor's Supervision	53
Article 41.	Inspector's Field Office	54
Article 42.	Documents on Work	54
Article 43.	Utilities and Relocation	54
Article 44.	Sanitary Facilities	55
Article 45.	Trenches	55
Article 46.	Protection of Work and Property	56
Article 47.	Lay Out and Field Engineering	57
Article 48.	Cutting and Patching	57
Article 49.	Cleaning Up	57
Article 50.	Correction of Work	57
Article 51.	Access to Work	57
Article 52.	Occupancy	58
Article 53.	County's Inspector	58
Article 54.	Tests and Inspections	58
Article 55.	Soils Investigation Report	59
Article 56.	Architect/Engineer's and Construction Manager's Status	59
Article 57.	Indemnities	59
Article 58.	Provisions Required by Law Deemed Inserted	60
Article 59.	Labor - Employment Safety	60
Article 60.	Notice of Taxable Possessory Interest	60
Article 61.	Assignment of Unfair Business Practices Claims (Clayton Act & Cartwright Act)	61
Article 62.	Substitution of Security	61
Article 63.	Non-Discrimination & Disadvantaged Business Enterprise Program	61
Article 64.	Special Conditions *	62
Article 65.	Contract Construction	62
Article 66.	Cognizance of Violations by County	62
Article 67.	Labor Standards Compliance Requirements	63
Article 68.	Conflict of Interest and Gratuities	63
Article 69.	Federal Contract Requirements	64
Article 70.	Miscellaneous	68

## GENERAL CONDITIONS

### **Article 1. DEFINITIONS**

- (a) COUNTY and Contractor are those mentioned as such in the Agreement. They are treated throughout the Agreement as if they are of singular number and neuter gender.
- (b) Subcontractor, as used herein, includes those having direct contract with Contractor and one who furnishes material work to a special design according to plans and specifications of this work, but does not include one who merely furnishes material not so worked.
- (c) Surety is the person, firm, or corporation that executes as surety the *Contractor's Performance Bond and Payment Bond for the Public Works*.
- (d) Provide shall include "provide complete in place," that is, "furnish and install."
- (e) As Shown, As Indicated, As Detailed, refer to drawings accompanying these specifications.
- (f) Work of the Contractor or subcontractor includes labor or materials, or both.

### **Article 2. DRAWINGS AND SPECIFICATIONS**

Contract Documents are complementary, and what is called for by one shall be as binding as if called for by all. The intention of documents is to include all labor and materials, equipment, and transportation necessary for the proper execution of work. Materials or work described in words which so apply have a well-known technical or trade meaning, and shall be deemed to refer to such recognized standards.

Interpretations. Figured dimensions on drawings shall govern, but work not dimensioned shall be as directed. Work not particularly shown or specified shall be the same as similar parts that are shown or specified. Large-scale details shall take precedence over smaller scaled drawings as to shape and details of construction. Specifications shall govern as to materials, workmanship, and installation procedures. Drawings and specifications are intended to be fully cooperative and to agree. However, if Contractor observes that drawings and specifications are in conflict, it shall promptly notify the Architect in writing, and any necessary changes shall be adjusted as provided in the contract for changes in work.

Misunderstanding of drawings and specifications shall be clarified by the Architect, whose decision shall be final.

Standards, Rules, and Regulations referred to are recognized printed standards, and shall be considered as one and a part of these specifications within limits specified.

### **Article 3. COPIES FURNISHED**

Contractor will be furnished, free of charge, copies of drawings and specifications as set forth in *Special Conditions*. Additional copies may be obtained at cost of reproduction.

### **Article 4. OWNERSHIP OF DRAWINGS**

All drawings, specifications, and copies thereof furnished by COUNTY are its property. They are not to be used on other work, and, with exception of signed contract sets, are to be returned to COUNTY on request at completion of work.

**Article 5. DETAIL DRAWINGS AND INSTRUCTIONS**

- (a) In case of ambiguity, conflict, or lack of information, Architect/Engineer shall furnish with reasonable promptness additional instructions, by means of drawings or otherwise, necessary for proper execution of work. All such drawings and instructions shall be consistent with contract documents, true developments thereof, and reasonably inferable therefrom.
  
- (b) Work shall be executed in conformity therewith, and Contractor shall do no work without proper drawings and instructions.

**Article 6. TIME FOR COMPLETION AND DAMAGES FOR DELAY**

The Parties recognize that time is of the essence of the Agreement and that COUNTY will suffer financial loss if the Work is not completed by the date set forth in paragraph 19.9 of the Information to Bidders section of this Agreement. The Parties also recognize the delays, expense and difficulties involved with proving in a legal proceeding the actual loss suffered by COUNTY if the Work is not completed on time. Accordingly, instead of requiring any such proof, the Parties agree that as damages for delay (but not as a penalty), Contractor shall pay COUNTY the sum of **two thousand nine hundred 00/100 dollars (\$2,900)** for each calendar day the Work remains uncompleted after the time specified in this article or any written extension, whichever is later. Contractor agrees that the damages are not manifestly unreasonable under the circumstances and agree that such sum is not intended as a penalty against Contractor.

**Article 7. PROGRESS SCHEDULE**

Immediately after being awarded contract, Contractor shall prepare an estimated progress schedule (using the Critical Path Method (CPM) through a software program selected by COUNTY but at Contractor's sole expense) and submit the schedule for COUNTY's approval. Schedule shall indicate graphically the beginning and completion dates of all phases of construction. An updated progress schedule shall be submitted to COUNTY on a monthly basis.

**Article 8. CONTRACT SECURITY**

Unless otherwise specified, Contractor shall furnish a surety bond in an amount equal to one hundred percent (100%) of the contract price as security for faithful performance of this contract, and shall furnish a separate bond in an amount equal to one hundred percent (100%) of the contract price as security for payment of persons performing labor and furnishing materials in connection with this contract. Aforesaid bonds shall be in form set forth in these contract documents. Upon request of Contractor, COUNTY will consider and accept multiple sureties on such bonds. COUNTY may reject at its discretion any bond issued by a surety that to COUNTY's satisfaction does not have a sufficient bond rating or history as a surety in the State of California to assure adequate security to COUNTY for the default of Contractor.

**Article 9. ASSIGNMENT**

Contractor shall not assign this contract or any part thereof without prior written consent of COUNTY. Any assignment of money due to or to become due under this contract shall be subject to a prior lien for services rendered or material supplied for performance of work called for under said contract in favor of all persons, firms, or corporations rendering such services or supplying such materials to the extent that claims are filed pursuant to the Civil Code, the Code of Civil Procedure, Public Contract Code and/or the Government Code.

#### **Article 10. PROHIBITED INTERESTS**

No official of COUNTY who is authorized in such capacity and on behalf of COUNTY to negotiate, make, accept or approve, or to take part in negotiating, making, accepting or approving, any architectural, engineering, inspection, construction, or material supply contract or any subcontract in connection with construction or project shall become directly or indirectly interested financially in this contract or in any part thereof. No officer, employee, architect, attorney, engineer, or inspector of or for COUNTY who is authorized in such capacity and on behalf of COUNTY to exercise any executive, supervisory, or other similar functions in connection with construction of project shall become directly or indirectly interested financially in this contract or in any part thereof.

#### **Article 11. SEPARATE CONTRACTS**

COUNTY reserves the right to let other contracts in connection with this work. Contractor shall afford other Contractors reasonable opportunity for introduction and storage of their materials and execution of their work and shall properly connect and coordinates its work with theirs.

If any part of Contractor's work depends for proper execution or results upon work of any other Contractor, the Contractor shall inspect and promptly report to Architect/Engineer any defects in such work that render it unsuitable for such proper execution and results. Contractor's failure so to inspect and report shall constitute its acceptance of other Contractor's work as fit and proper for reception of Contractor's work, except as to defects which may develop in other Contractor's work after execution of Contractor's work.

To ensure proper execution of its subsequent work, Contractor shall measure and inspect work already in place, and shall at once report to Architect any discrepancy between executed work and contract documents.

Contractor shall ascertain to its own satisfaction the scope of the project and nature of any other contracts that have been or may be awarded by COUNTY in prosecution of the project to the end that Contractor may perform its contract in the light of such other contracts, if any. Nothing herein contained shall be interpreted as granting to Contractor exclusive occupancy at site of project. Contractor shall not cause any unnecessary hindrance or delay to any other Contractor working on project. If simultaneous execution of any contract for the project is likely to cause interference with performance of some other contract or contracts, COUNTY shall decide which Contractor shall cease work temporarily and which Contractor shall continue or whether work can be coordinated so that Contractors may proceed simultaneously. COUNTY shall not be responsible for any damages suffered or extra costs incurred by Contractor resulting directly or indirectly from award or performance or attempted performance of any other contract or contracts on project, or caused by any decision or omission of COUNTY respecting the order of precedence in performance of contracts.

## **Article 12. SUBCONTRACTING**

- (a) Contractor agrees to bind every subcontractor by terms of the contract as far as such terms are applicable to subcontractor's work. If Contractor shall subcontract any part of this contract, Contractor shall be as fully responsible to COUNTY for acts and omissions of Contractor's subcontractor and of persons either directly or indirectly employed by Contractor's subcontractor as it is for acts and omissions of persons directly employed by itself. Nothing contained in the contract documents shall create any contractual relation between any subcontractor and COUNTY.
- (b) COUNTY's consent to or approval of any subcontractor under this contract shall not in any way relieve Contractor of its obligations under this contract, and no such consent or approval shall be deemed to waive any provision of this contract.
- (c) Substitution or addition of subcontractors shall be permitted only as authorized by California Public Contract Code sections 4100, et seq.
- (d) Contractor represents and warrants that it and its subcontractors are not ineligible to work for COUNTY due to violations of Labor Code sections 1777.1 and 1777.7.

## **Article 13. DEFAULTS & REMEDIES**

- (a) Default. In the event that (i) Contractor files a petition requesting relief under any bankruptcy act, or is adjudged as bankrupt, or makes a general assignment for the benefit of creditors or has a receiver appointed on account of its insolvency, or (ii) Contractor refuses or is unable, for whatever reason, to supply enough properly skilled workers or proper materials to complete the Project, or (iii) Contractor fails to follow the directions of COUNTY, or (iv) Contractor fails to make prompt payment to its subcontractors and suppliers for materials or labor supplied or permits any lien to be imposed upon all or any portion of the Project, or (v) Contractor disregards any laws or orders of any public or private authority having jurisdiction over the Work or the Project, or (vi) Contractor fails to perform in accordance with any of the terms of this Agreement or breaches any provision of this Agreement, COUNTY may give notice of such failure or breach to Contractor, identifying the failure or breach of this Agreement. Should any such failure or breach continue for twenty-four (24) hours after delivery of notice without a good faith effort on the part of Contractor to commence all necessary corrective action, or should such a breach continue despite Contractor's efforts for forty-eight (48) hours, then at that time such failure shall be deemed a default by Contractor under this Agreement and COUNTY shall have all rights and remedies available at law or in equity, including the right to terminate this Agreement. Without limiting its rights and remedies, COUNTY may then proceed as follows:
  - (1) Without terminating this Agreement or the obligations of Contractor hereunder as to all of the Work required to be performed or furnished by Contractor pursuant to this Agreement, COUNTY may require Contractor, at Contractor's expense, to cure such default(s) as may exist in the performance of Contractor's obligations hereunder within forty-eight (48) hours after such default(s) has/have occurred including but not limited to repairing, replacing, and correcting material or Work determined by COUNTY to be defective or not complying with the requirements of

this Agreement. Should Contractor fail to timely repair, replace, and/or correct non-complying or defective materials and workmanship or otherwise cure its default(s) hereunder, and in the case of emergencies in which case COUNTY may act immediately if Contractor is not available or is not responding, and without further notice, COUNTY may make required repairs, replacements and other corrections or otherwise remedy the default by Contractor pursuant to Paragraph (2) below.

- (2) Without terminating this Agreement or the obligations of Contractor hereunder as to all of the Work required to be performed or furnished by Contractor pursuant to this Agreement, COUNTY may engage another contractor to perform such portion of Contractor's Work required pursuant to this Agreement or furnish any materials or other items required hereunder as COUNTY in its sole discretion may deem necessary to avoid delay in the progress of the Work, and in connection therewith, COUNTY may perform such Work or any portion thereof itself or have the same performed by others and COUNTY may procure all necessary materials, equipment or other items required for the continued progress of such Work. The costs incurred by COUNTY as a result of engaging another Contractor shall be deducted from the compensation payable pursuant to this Agreement and if COUNTY's costs exceed or may reasonably be anticipated to exceed the balance of the compensation due to Contractor for such work, such excess, or anticipated excess, shall be immediately due and owing from Contractor to COUNTY and may be withheld from any funds due to Contractor pursuant to this Agreement or any other agreement.
  - (3) COUNTY may terminate Contractor's right to perform upon written notice and COUNTY shall then have the option of completing the Work or any portion thereof by exercise of its interest under the performance bond issued in favor by Contractor, or having such Work in whole or in part be completed by others for Contractor's account. A calculation shall take place at the conclusion of the Project wherein to the degree the sum of COUNTY's costs and any amounts paid to complete the Project exceed the compensation payable pursuant to this Agreement, then any such excess shall be immediately due and owing from Contractor to COUNTY.
- (b) **Damages.** Contractor shall be liable for all damages suffered by COUNTY by reason of Contractor's default in any provision of this Agreement and the exercise of COUNTY of its option to terminate this Agreement shall not release Contractor of such liability. Contractor shall have no right to receive any further payment after a default has occurred until such time as the Work to be performed by Contractor pursuant hereto has been completed and accepted by COUNTY and damages suffered by COUNTY, if any, ascertained. Damages shall include by way of illustration, but not of exclusion, COUNTY's costs of completing the Work which exceeds the compensation payable pursuant to this Agreement, other general, liquidated, special or consequential damages, attorney fees, and costs.
- (c) **Actions After Default.** Should COUNTY exercise any of its options, remedies, or rights granted pursuant to the terms of this Agreement in the event of a default by Contractor, COUNTY at its sole election may, but shall not be obligated to, use any materials,



supplies, tools or equipment on the work site which belong to CONTRACTOR to complete the Work required to be completed by Contractor, whether such work is completed by COUNTY or by others, and Contractor agrees that it shall not remove such materials, supplies, tools and equipment from the work site unless directed in writing by COUNTY to do so.

- (d) Limit on Force Majeure Damages. Contractor shall not be responsible for repairing or restoring damage to work caused by an act of God, provided that the work damaged is built in accordance with accepted and applicable building standards and the plans and specifications of COUNTY. In the event of such damage, COUNTY may, at its option, elect to terminate this Agreement. For purposes of this Agreement, an "act of God" shall be defined as an earthquake in excess of 3.5 on the Richter scale and a tidal wave.
- (e) No Limitation of Rights. The options and rights granted to COUNTY herein shall not be deemed as limitations upon the other rights and remedies of COUNTY in the event of a failure of performance or breach by Contractor, and COUNTY shall be entitled to exercise the rights and remedies hereinabove specified and all other rights and remedies which may be provided in this Agreement or by law or in equity, either cumulatively or consecutively, and in such order as COUNTY in its sole discretion shall determine.

#### **Article 14. WARRANTIES**

- (a) One-Year Warranty. Contractor agrees to provide a one-year warranty for all of its work and component parts and guarantees that all work shall be performed in a professional and workman-like manner and be free from defects. Contractor guarantees to timely correct all work performed by it under this Agreement which COUNTY determines to be defective in design, material, and/or workmanship within a period of one (1) year from the date of the completion of the Work. The warranties set forth in this Agreement shall be in addition to, and not in lieu of, all other statutory and case law warranties and obligations of Contractor. Contractor expressly agrees that all warranties made by Contractor, all obligations under this Agreement and all remedies for breach of such warranties shall survive this Agreement in the event it is terminated or expires for any reason prior to the running of the full warranty periods listed above.

Note: Product Warranty on specifications.

- (b) Materials. All materials furnished by Contractor shall be new, manufactured during the current year, of first quality, and carrying full manufacturer's warranty. Contractor shall be responsible for any expiration of manufacturer or other warranties of material or equipment being supplied for this Agreement. Contractor guarantees that all warranties of material and equipment shall become effective when the project is accepted by COUNTY's Board of Supervisors, not at time of installation by Contractor.
- (c) Manufacturers' Warranty Information. Contractor agrees to promptly provide such information and maintenance recommendations to COUNTY at the inception of Contractor's work to the extent such information is reasonably available. In the event of failure of Contractor to comply with above-mentioned conditions within one (1) week after being notified in writing, COUNTY is hereby authorized to proceed to have defects repaired and made good at expense of Contractor, who hereby agrees to pay costs and

charges therefore immediately on demand.

**Article 15. NOTICES AND REPORTS**

(a) All notices and reports under this Agreement shall be in writing and may be given by personal delivery or by mailing by certified mail, addressed as follows:

COUNTY

Imperial County Department of Public Works  
Attention: Director  
155 South Eleventh Street  
El Centro, CA 92243

With Copies to:

Imperial County Executive Office  
Attention: County Executive Officer  
940 West Main Street, Suite 208  
El Centro, CA 92243

and:

Imperial County Department of Human  
Resources and Risk Management  
Attention: Director  
940 West Main Street, Suite 101  
El Centro, CA 92243

CONTRACTOR

Business Name:

---

---

Address:

---

---

---

---

(b) Notices and reports under this Agreement may be given by personal delivery or by mailing by certified mail at such other address as either Party may designate in a notice to the other Party given in such manner. Any notice given by mail shall be considered given when deposited in the United States Mail, postage prepaid, addressed as provided herein.

**Article 16. WORKERS**

(a) Contractor shall at all times enforce strict discipline and good order among its employees, and shall not employ on work any unfit person or anyone not skilled in work assigned to that person. Contractor shall at all times enforce rules and standards regarding sensitive information. Contractor shall not permit workers to touch or otherwise touch, read, review, copy, or access any sensitive or confidential information. Contractor shall be responsible for any worker violating sensitive information standards.

(b) Any person in the employ of the Contractor whom COUNTY may deem incompetent or unfit shall be dismissed from work, and shall not again be employed on it except with written consent of COUNTY.

(c) Contractor shall provide COUNTY with a list of all current employees. Contractor shall notify COUNTY of all new employees one week prior to their start date.

- (d) All Contractor's employees shall be required to comply with the work rules established for the project site; and shall be identified while on the premises by picture identification card furnished at his/her expense, indicating their name or number; and by shirt, blouse or smock indicating the company name or logo in print large enough to be easily read. Contractor's employees shall have effective communication skills to perform such tasks and communicate with the COUNTY and its representatives.
- (e) It shall be the responsibility of Contractor to ensure all workers do not access sensitive information. COUNTY shall have the right to perform a background check and clearance requirements of all workers that have access to sensitive information. Notwithstanding anything in this agreement to the contrary, the Contractor must comply with background check and clearance requirements of the California Department of Justice (DOJ) and the California Department of Motor Vehicles (DMV) relating to any Contractor employee who has physical access to any area which is either connected to, or contains records from, the DOJ criminal computer database, including without limitation, the California Law Enforcement Telecommunications System and the Criminal Offender Record Information, or the DMV computer database (collectively, "the Databases"). If requested by the COUNTY, the Contractor must provide to the COUNTY suitable documentation evidencing the Contractor's compliance with the policies, practices, and procedures of the DOJ and the DMV regarding background check and clearance requirements relating to access to the Databases.

#### **Article 17. PREVAILING WAGE AND PAYROLL RECORDS**

- (a) Contractor agrees to comply with sections 1775 and 1776 of the California Labor Code relating to the payment of prevailing wage and the maintenance of certified payroll records and to make the certified payroll records available for inspection at all reasonable hours at Contractor's principal office. For those Public Works Projects that are subject to the State Department of Industrial Relations (DIR), Division of Labor Standards Enforcement (DLSE) compliance monitoring and enforcement it is the Contractor's responsibility to submit certified payroll records directly to the state Compliance Monitoring Unit (CMU). More information concerning state compliance can be found at <https://www.dir.ca.gov/Public-Works/publicworks.html>. The responsibility for compliance with these provisions is fixed with Contractor. Contractor understands and agrees that it shall, as a penalty to COUNTY, forfeit specific monetary fines for each worker paid less than the prevailing wage rates as determined by the Labor Commissioner for the work or craft in which the worker is employed for any Work done pursuant to this Agreement.
- (b) Notwithstanding paragraph (a), Contractor is not liable for any penalties pursuant to paragraph (a) when a subcontractor on the Project fails to pay its workers the general prevailing rate of per diem wages unless:
  - (1) Contractor had knowledge of that failure of the subcontractor to pay the specified prevailing rate of wages to those workers; or
  - (2) Contractor fails to comply with all of the following requirements:
    - (A) The contract executed between Contractor and the subcontractor for the performance of Work on the Project shall include a copy of the provisions of

California Labor Code sections 1771, 1775, 1776, 1777.5, 1813 and 1815; and

- (B) Contractor shall monitor the payment of the specified general prevailing rate of per diem wages by the subcontractor to the employees, by periodic review of the certified payroll records of the subcontractor; and
- (C) Upon becoming aware of the failure of the subcontractor to pay his or her workers the specified prevailing rate of wages, Contractor shall diligently take corrective action to halt or rectify the failure, including, but not limited to, retaining sufficient funds due the subcontractor for work performed on the public works project; and
- (D) Prior to making final payment to the subcontractor for Work performed on the Project, Contractor shall obtain an affidavit signed under penalty of perjury from the subcontractor that the subcontractor has paid the specified general prevailing rate of per diem wages to his or her employees on the Project and any amounts due pursuant to California Labor Code section 1813.
- (E) Prevailing Wage Compliance. Contractor and its subcontractors shall pay all workers employed on the Project the rates determined by the Director of the California Department of Industrial Relations (DIR). Copies of the State prevailing rate of per diem wages are on file with the Department of Industrial Relations, Division of Apprenticeship Standards, 445 Golden Gate Avenue, San Francisco, California, and at COUNTY's Department of Public Works, and are available to Contractor and any other interested party upon request. Contractor shall post the prevailing rate of per diem wages to be posted at the Project site.

#### **Article 18. APPRENTICES**

- (a) Contractor agrees to comply with sections 1777.5, 1777.6 and 1777.7 of the California Labor Code relating to the employment of apprentices and to provide COUNTY with copies of any contract award information and verified statements of the journeyman and apprentice hours performed pursuant to this Agreement as required by section 1777.5(e). The responsibility for compliance with these provisions is fixed with Contractor for all apprenticeable occupations, where journeymen in the craft are employed on the public work, in a ratio of not less than one (1) apprentice for each five (5) journeymen (unless an exemption is granted in accordance with section 1777.5) and Contractor and its subcontractors shall not discriminate among otherwise qualified employees as indentured apprentices on any public work solely on the ground of race, religious creed, color, national origin, ancestry, sex, or age, except as provided in California Labor Code section 3077. Only apprentices, as defined in California Labor Code section 3077, who are in training under apprenticeship standards and who have signed written apprentice agreements will be employed on public works in apprenticeable occupations. This section shall not be enforced if the not-to-exceed amount of this Agreement is less than thirty thousand dollars (\$30,000).
- (b) If the Project falls within the jurisdiction of California Labor Code section 1777.5,

COUNTY shall, within five (5) days of the award, send a copy of the award to the Division of Apprenticeship Standards. In addition, COUNTY shall notify the Division of Apprenticeship Standards of a finding of any discrepancy regarding the ratio of apprentices to journeymen within five (5) days of the finding.

**Article 19. HOURS OF WORK**

Contractor agrees to comply with sections 1810 through 1815 of the California Labor Code and, when applicable, the Contract Work Hours and Safety Standards Act (40 USC §327 et seq.; 29 CFR Part 5) which provide that Contractor's workers and its subcontractor's workers may not be required or permitted to work more than eight (8) hours in any one (1) calendar day and forty (40) hours in any one (1) calendar week. Further, work performed by employees of Contractor or its subcontractor in excess of eight (8) hours per day, and forty (40) hours during any one (1) week, shall be compensated for all hours worked in excess of eight (8) hours per day at not less than one and one-half (1½) times the basic rate of pay. The responsibility for compliance with these provisions is fixed with Contractor. Contractor understands and agrees that it shall, as a penalty to COUNTY, forfeit specific monetary fines to COUNTY should Contractor or its subcontractors fail to comply with the provisions contained within this paragraph.

**Article 20. INSURANCE COVERAGES**

Contractor hereby agrees at its own cost and expense to procure and maintain, during the entire term of this Agreement and any extended term therefore, insurance in a sum acceptable to COUNTY and adequate to cover potential liabilities arising in connection with the performance of this Agreement and in any event not less than the minimum limit set forth as follows:

<u>INSURANCE</u>	<u>MINIMUM LIMIT</u>
<u>Worker's Compensation, Coverage A</u>	Statutory
<u>Employers Liability, Coverage B</u>	\$1,000,000.00 per accident for bodily injury or disease
<u>Commercial General Liability Including Contractual Liability</u> Operations, Products and Completed Operations:	
Personal/Bodily Injury	\$1,000,000.00 / occurrence \$2,000,000.00 / aggregate
Property Damage	\$1,000,000.00 / occurrence \$2,000,000.00 / aggregate
<u>Commercial Automobile Liability</u> (owned, hired, & non-owned vehicles)	
Personal/Bodily Injury & Property Damage	\$1,000,000.00
Unemployment Insurance	To Be Determined by Scope of Work
Disability Insurance	To Be Determined by Scope of Work

**Article 21. SPECIAL INSURANCE REQUIREMENTS**

(a) All insurance required under Article 20 shall:

- (1) Be procured from an insurer authorized to do business in California.
- (2) Be primary coverage as respects COUNTY and any insurance or self-insurance maintained by COUNTY shall be in excess of Contractor's insurance coverage and

- shall not contribute to it.
- (3) Name COUNTY as an additional insured on all policies, except Workers' Compensation, and provide that COUNTY may recover for any loss suffered by COUNTY by reason of Contractor's negligence.
  - (4) State that it is primary insurance and regards COUNTY as an additional insured and contains a cross-liability or severability of interest clause.
  - (5) Not be canceled, non-renewed, or reduced in scope of coverage until after thirty (30) days written notice has been given to COUNTY. However, Contractor may not terminate such coverage until it provides COUNTY with proof that equal or better insurance has been secured and is in place. Cancellation or change without the prior written consent of COUNTY shall, at the option of COUNTY, be grounds for termination of this Agreement.

(b) Additional Insurance Requirements.

- (1) Complete copies of certificates of insurance for all required coverages including additional insured endorsements and thirty-day (30-day) notice of cancellation clause endorsements shall be attached hereto as Exhibit E and incorporated herein as though fully set forth.
- (2) COUNTY is to be notified immediately of all insurance claims. COUNTY is also to be notified if any aggregate insurance limit is exceeded.

(c) Nothing in this, or any other provision of this Agreement, shall be construed to preclude Contractor from obtaining and maintaining any additional insurance policies in addition to those required pursuant to this Agreement.

**Article 22. INSURANCE ENDORSEMENTS, CLAUSES, & INFORMATION**

(a) The comprehensive/commercial general liability insurance shall contain a provision of endorsements stating that such insurance:

- (1) Includes contractual liability;
- (2) Does not contain a "pro rata" provision which looks to limit the insurer's liability to the total proportion that its policy limits bear to the total coverage available to the insured;
- (3) Does not contain an "excess only" clause which requires the exhaustion of other insurance prior to providing coverage;
- (4) Does not contain an "escape clause" which extinguishes the insurer's liability if the loss is covered by other insurance;
- (5) Includes COUNTY, architect, and the construction manager as an additional insured;
- (6) States that it is primary insurance and regards COUNTY as an additional insured and contains a cross-liability or severability of interest clause; and
- (7) Does not contain any exclusion as to loss or damage to property caused by

explosion or resulting from collapse of buildings or structures or damage to property underground, commonly referred to by insurers as the "XCU Hazards."

- (b) Certificates and insurance policies shall include the following clause: "This policy shall not be canceled or reduced in required limits of liability or amount of insurance until notice has been mailed to COUNTY stating date of cancellation or reduction. Date of cancellation may not be less than thirty (30) days after date of mailing notice."
- (c) Certificates of insurance shall state, in particular, those insured, extent of insurance, location and operation to which insurance applies, expiration date, and cancellation and reduction notice.

### **Article 23. PROOF OF INSURANCE**

Contractor shall not commence work nor shall it allow any subcontractor to commence work under this Agreement until Contractor has obtained all required insurance, certificates and endorsements, including but not limited to, Additional Insured Endorsements and thirty-days (30-days) Notice of Cancellation Clause endorsements have been delivered in duplicate to and approved by COUNTY. The above referenced insurance documents must be received by COUNTY on or before the effective date of this Agreement and shall be sent to the following addresses:

- (i) County of Imperial  
Risk Management Department  
940 Main Street, Suite 101  
El Centro, CA 92243
- and
- (ii) Department of Public Works  
Attn: Director of Public Works  
1002 State Street  
El Centro, CA 92243

### **Article 24. CHOICE OF LAW**

The laws of the State of California shall govern this Agreement. This Agreement is made and entered into in Imperial County, California. Any action brought by either Party with respect to this Agreement shall be brought in a court of competent jurisdiction within said County.

### **Article 25. PERMITS AND LICENSES**

Permits and licenses necessary for prosecution of work shall be secured and paid for by Contractor, unless otherwise specified.

### **Article 26. EASEMENTS**

Easements for permanent structures or permanent changes in existing facilities shall be secured and paid for by COUNTY, unless otherwise specified.

### **Article 27. SURVEYS**

Surveys to determine location of property lines and corners will be supplied by COUNTY. Surveys to determine locations of construction, grading, and site work shall be provided by

Contractor.

**Article 28. EXCISE TAXES**

If under federal excise tax law any transaction hereunder constitutes a sale on which a federal excise tax is imposed and the sale is exempt from such excise tax because it is a sale to a state or local government for its exclusive use, COUNTY, upon request, will execute a certificate of exemption which will certify: (a) that COUNTY is a political subdivision of the state for the purpose of such exemption; and (b) that the sale is for the exclusive use of COUNTY. No excise tax for such materials shall be included in any bid price.

**Article 29. PATENTS AND ROYALTIES**

Contractor shall hold and save COUNTY and its officers, agents, and employees harmless from liability of any nature or kind, including cost and expense, for or on account of any patented or unpatented invention, process, article, or appliance manufactured or used in the performance of this contract, including its use by COUNTY, unless otherwise specifically stipulated in the contract documents.

**Article 30. MATERIALS**

Except as otherwise specifically stated in this contract, Contractor shall provide and pay for all materials, labor, tools, equipment, water, light, power, transportation, superintendence, temporary constructions of every nature, and all other services and facilities of every nature whatsoever necessary to execute and complete this contract within the specified time.

Unless otherwise specified, all materials shall be new, and both workmanship and materials shall be of good quality.

Materials shall be furnished in ample quantities and at such times as to insure uninterrupted progress of work, and shall be stored properly and protected as required. Contractor shall be entirely responsible for damage or loss by weather or other causes to materials or work under this contract. No material, supplies, or equipment for work under this contract shall be purchased subject to any chattel mortgage or under a conditional sale or other agreement by which an interest herein or in any part thereof is retained by seller or supplier. Contractor warrants good title to all material, supplies, and equipment installed or incorporated in work, and agrees upon completion of all work to deliver premises, together with all improvements and appurtenances constructed or placed thereon by Contractor, to COUNTY free from any claims, liens, or charges. Contractor further agrees that neither Contractor nor any person, firm, or corporation furnishing materials or labor for any work covered by this contract shall have any right to lien upon premises or any improvement or appurtenance thereon, except that Contractor may install metering devices or other equipment of utility companies or of political subdivisions title to which is commonly retained by utility company or political subdivision. In event of installation of any such metering device or equipment, Contractor shall advise COUNTY as to owner thereof. Nothing contained in this Article, however, shall defeat or impair the right of persons furnishing material or labor under any bond given by Contractor for their protection or any rights under any law permitting such persons to look to funds due Contractor in hands of COUNTY, and this provision shall be inserted in all subcontracts and material contracts, and notice of its provisions shall be given to all persons furnishing material for work when no formal contract is entered into for such material.

See Comprehensive Specifications for material requirements.



**Article 31. SUBSTITUTIONS**

Whenever specifications for any material, product, thing, service, or process is indicated or specified by grade, patent or propriety name or by name of manufacturer, such specifications shall be deemed to be used for the purpose of facilitating the description of material, product, thing, service, or process desired, and shall be deemed to be followed by the words “or equal”, and Contractor may, unless otherwise stated, offer any material, product, thing, service or process which shall be equal or better in every respect to that so indicated or specified. If the material, product, thing, service, or process offered by Contractor is not, in the opinion of COUNTY and Architect/Engineer, equal or better in every respect to that specified, then Contractor shall furnish the material, product, thing, service, or process specified. The burden of proof as to equality of any material, product, thing, service, or process shall rest with Contractor. Contractor shall only be authorized to substitute any designated material, product, thing, service or process required under this contract if such request, together with substantiating data for substitution of an “or equal” item is timely submitted in accordance with the Calendar of Events set forth under section 19.3 of the “INFORMATION FOR BIDDERS” form and approval thereof is authorized in writing by COUNTY within the time frame set forth under Public Contract Code section 4104.5(a). Notwithstanding, in the event CONTRACTOR discovers after the stated substitution request filing deadline that a designated material, product, thing, service or process is no longer available and/or the use of the same is necessary to complete the project, CONTRACTOR may within thirty (30) days after award of the contract submit a “late substitution request”, together with substantiating data for substitution of an “or equal” item for COUNTY’s review and consideration. However, COUNTY shall have the sole discretion in granting such a late substitution request and shall not be required to accept the same even if the material, product, thing, service or process is equal or better in every respect.

It should be emphasized that a Contractor’s request to substitute an “equal” material, product, thing or service for one designated in the contract specifications and/or COUNTY’s subsequent written approval thereof, shall not in any way authorize an extension of time for performance of this contract. Moreover, in event Contractor furnishes a material, product, thing or service that is more expensive than that specified, the difference in cost of such material, product, thing, service or process, so furnished shall be borne solely by Contractor.

**Article 32. SHOP DRAWINGS**

Contractor shall check and verify all field measurements, and shall submit with such promptness as to cause no delay in Contractor’s own work or in that of any other Contractor three (3) copies, checked and approved by Contractor, of all shop or setting drawings, schedules and materials lists required for the work of various trades. Architect/Engineer shall check and approve within ten (10) working days such schedules and drawings only for conformance with design concept of project, and compliance with information given in contract documents. Contractor shall make any corrections required by Architect/Engineer; file with Architect/Engineer three (3) corrected copies, and furnish such other copies as may be needed for construction. Architect/Engineer’s approval of such drawings or schedules shall not relieve Contractor from responsibility for deviations from drawings or specifications unless Contractor has in writing called Architect/Engineer’s attention to such deviations at time of submission and secured Architect/Engineer’s written approval, nor shall it relieve Contractor from responsibility for errors in shop drawings or schedule.

### **Article 33. SAMPLES**

Contractor shall furnish for approval, within ten (10) days following award of contract, all samples as required in specifications together with catalogs and supporting data required by Architect/Engineer. This provision shall not authorize any extension of time for performance of this contract. Architect/Engineer will check and approve such samples, within five (5) working days from receipt of same, only for conformance with design concept of work and for compliance with information given in contract documents. Work shall be in accordance with approved samples.

### **Article 34. COST BREAKDOWN AND PERIODICAL ESTIMATES**

Contractor shall furnish on forms provided by COUNTY:

- (a) Within ten (10) days of award of contract, a detailed estimate giving complete breakdown of contract price.
- (b) A periodical itemized estimate of work done for purpose of making partial payments thereon.
- (c) Within ten (10) days of request by COUNTY, a schedule of estimated monthly payments which shall be due Contractor under the contract.

Values employed in making up any of these schedules will be used only for determining basis of partial payments, and will not be considered as fixing a basis for additions to or deductions from contract price.

- (d) **Schedule of Values.** Prior to submitting the first application for payment, Contractor must prepare and submit to the County a schedule of values apportioned to the various divisions and phases of the Work, including mobilization and demobilization. If a Bid Schedule was submitted with Contractor's bid, the amounts in the schedule of values must be consistent with the Bid Schedule. Each line item contained in the schedule of values must be assigned a value such that the total of all items equals the Contract Price. The items must be sufficiently detailed to enable accurate evaluation of the percentage of completion claimed in each application for payment, and the assigned value consistent with any itemized or unit pricing submitted with Contractor's bid.

### **Article 35. PAYMENTS**

- (a) Each month, within fifteen (15) days after receipt of approved periodical estimate for partial payment, there shall be paid to Contractor a sum equal to ninety-five percent (95%) of value of work performed up to last day of previous month, less aggregate of previous payments. Monthly payments shall be made only on basis of monthly estimates which shall be prepared by Contractor on a form approved by COUNTY and filed before the fifth (5th) day of month during which payment is to be made. Work completed as estimated shall be an estimate only, and no inaccuracy or error in said estimate shall operate to release Contractor or any bondsman from damages arising from such work or from enforcing each and every provision of this contract, and COUNTY shall have the right subsequently to correct any error made in any estimate for payment. Contractor shall not be entitled to have any payment estimates processed or be entitled to have any payment made for work performed so long as any lawful or

proper direction concerning work, or any portion thereof given by COUNTY or Architect, shall remain uncompleted. The final payment of five percent (5%) of the value of work done under this contract, if unencumbered, shall be made thirty-five (35) days after acceptance of work by COUNTY. Acceptance will be made only by action of the Board of Supervisors in session. Acceptance by Contractor of said final payment shall constitute a waiver of all claims against COUNTY arising from this contract. At any time after fifty percent (50%) of the work has been completed, if COUNTY, by action of its governing body, finds that satisfactory progress is being made, COUNTY may make any of the remaining payments in full on actual work completed or may withhold any amount up to five percent (5%) thereof as COUNTY may find appropriate based on the Contractor's progress.

- (b) Contractor may elect to substitute or execute an escrow agreement (in the form prescribed by the Public Contracts Code) in place of retained funds held by COUNTY pursuant to Public Contract Code section 22300.
- (c) COUNTY shall pay interest at the legal rate set forth in Code of Civil Procedure 685.010 in the event payment is not made within thirty (30) days of an undisputed properly submitted request.

#### **Article 36. PAYMENT WITHHELD**

In addition to amount which COUNTY may retain under article entitled "Payments," COUNTY may withhold a sufficient amount of amounts of any payment or payments otherwise due to Contractor, as in COUNTY's judgment may be necessary to cover:

- (a) Payments which may be past due and payable for just claims against Contractor or any subcontractors for labor or materials furnished in and about the performance of work on the project under this contract.
- (b) Defective work not remedied.
- (c) Failure of Contractor to make proper payments to subcontractors or for material or labor.
- (d) Completion of contract, if there exists a reasonable doubt that contract can be completed for balance then unpaid.
- (e) Damage to another Contractor.

When the above grounds are removed, payment shall be made for amounts withheld because of them.

COUNTY may apply such withheld amount to payment of such claims or obligations at COUNTY's discretion. In so doing, COUNTY shall be deemed the agent of Contractor, and any payment so made by COUNTY shall be considered as a payment made under contract by COUNTY to Contractor, and COUNTY shall not be liable to Contractor for such payments made in good faith. Such payments may be made without prior judicial determination of claim or obligations. COUNTY will render Contractor a proper accounting of such funds disbursed on behalf of Contractor.

### **Article 37. CHANGES AND EXTRA WORK**

All change orders shall be subject to the Public Contract Code, including but not limited to sections 20137 and 20142, *et seq.*

- (a) **Change Orders.** Contractor shall make no changes to the Work to be performed pursuant to this Agreement, including but not limited to additions, deletions, modifications or substitutions, nor shall Contractor perform any extra work (collectively, "Change Order Work") without the prior written consent of COUNTY. If Contractor encounters conditions it considers different from those described in Exhibit A to this Agreement, Contractor may request a change order in conformance with COUNTY's standard procedure ("Change Order"). If COUNTY approves the request, Contractor will execute a Change Order and Contractor's execution of the Change Order shall confirm approval thereof. COUNTY may order additional work, and Contractor shall perform such changes in the Work as directed by COUNTY in any Change Order prepared by Contractor. COUNTY's rights to eliminate portions of the Work or to initiate a Change Order shall not be limited in any way. The Change Order shall be in writing and shall include:
- (1) Any and all supporting documents and drawings depicting the source and location of the desired change, and explain in detail the field conditions and reasons for the requested change;
  - (2) Any change or adjustment to the compensation set forth in this Agreement in Article 3 as a result of changes in the Work based on a lump sum or time and material basis, as may be directed by COUNTY; and
  - (3) Any request for adjustments to time for completion of the Project.
- (b) **Payment for Change Order Work.** Contractor shall not be entitled to receive any compensation for work, labor, materials or changes of any kind, regardless of whether ordered by COUNTY or any of its representatives, unless a Change Order has been submitted in writing and approved prior to the commencement of any Change Order Work as described above. If the changes are required by any inspecting governmental agencies or utility companies, or are otherwise required to comply with any codes, laws, rules or regulations, including those set forth in this Agreement, then Contractor shall not be entitled to any increases in the compensation set forth in this Agreement at Article 3 or other compensation as a result of the changes.
- (c) **Disputed Change Order Work.** Any dispute concerning the performance of such Change Order Work or the amount of compensation to be paid to Contractor by COUNTY shall not affect Contractor's obligation to perform such Change Order Work. Contractor agrees that it shall timely complete all Change Order Work even if there shall be a dispute between Contractor and COUNTY over the amount or scope of the Change Order Work. Contractor shall have the right to be compensated for any undisputed Change Order Work amounts as determined to be undisputed in COUNTY's sole discretion.
- (d) **Authorized Representative.** No Change Order shall be valid or binding against COUNTY unless such Change Order has been executed by COUNTY's designated representative, who is the Director of Public Works. COUNTY shall notify Contractor in writing if the designated representative is changed. The authority to execute a Change Order on this project shall not exceed the amount allowed by law pursuant to Government Code

sections 20137-20142, *et seq.*

**Article 38. DEDUCTIONS FOR UNCORRECTED WORK**

If COUNTY deems it inexpedient to correct work injured or done not in accordance with contract, an equitable deduction from contract price shall be made therefore.

**Article 39. PAYMENTS BY CONTRACTOR**

Contractor shall pay:

- (a) For all transportation and utility services not later than the twentieth (20th) day of the calendar month following that in which such services are rendered;
- (b) For all materials, tools and other expendable equipment to the extent of ninety-five percent (95%) of cost thereof, not later than the twentieth (20th) day of the calendar month following that in which such materials, tools and equipment are delivered at site of project and balance of cost thereof not later than the thirtieth (30th) day following completion of that part of the work in or on which such materials, tools and equipment are incorporated or used; and
- (c) To each of Contractor's subcontractors, not later than the fifth (5th) day following each payment to Contractor; the respective amounts allowed Contractor on account of work performed by respective subcontractor to the extent of such subcontractor's interest therein.

**Article 40. CONTRACTOR'S SUPERVISION**

Unless personally present on premises where work is being done, Contractor shall keep on the work, during its progress, a competent superintendent satisfactory to COUNTY.

Contractor represents and warrants that any superintendent, employee, subcontractor and agent who will be performing any of the duties and obligations of Contractor herein possess all required licenses and authorities, as well as the experience, training, and communication skills to perform such tasks and communicate with the COUNTY and its representatives.

Superintendent shall not be changed except with consent of COUNTY unless superintendent proves to be unsatisfactory to Contractor and ceases to be in his employ. Superintendent shall represent Contractor in Contractor's absence, and all directions given to superintendent shall be as binding as if given to Contractor. Other directions shall be so confirmed in written request in each case.

Contractor shall give efficient supervision to work, using Contractor's best skill and attention. Contractor shall carefully study and compare all drawings, specifications and other instructions, and shall at once report to Architect/Engineer any error, inconsistency or omission which Contractor may discover.

**Article 41. INSPECTOR'S FIELD OFFICE**

Contractor shall provide for use of COUNTY and its representative during construction working hours a temporary office of not less than seventy-five (75) square feet of floor area to be located as directed by COUNTY and its representative and to be maintained until

removal is authorized by COUNTY and its representative. Office shall be of substantial waterproof construction with adequate natural light and ventilation by means of stock design windows. Door shall have a key, type walk, or padlock hasp.

A table satisfactory for study of plans and two chairs shall be provided by Contractor. Contractor shall provide and pay for adequate electric lights, local telephone service, and adequate air conditioning and heating for the field office until authorized removal.

#### **Article 42. DOCUMENTS ON WORK**

Contractor shall keep one copy of all contract documents, including addenda and change orders which are a part of contract documents, on job at all times. Said documents shall be kept in good order and available to Architect/Engineer representatives. Contractor shall be acquainted with and comply with all California Administrative Code provisions relating to this project, including, but not limited to, Title 19.

#### **Article 43. UTILITIES AND RELOCATION**

(a) All utilities, including, but not limited to, electricity, water, gas and telephone used on work, shall be furnished and paid for by Contractor. Contractor shall furnish and install necessary temporary distribution systems, including meters if necessary, from distribution points to points on site where utility is necessary to carry on the work. Upon completion of work, Contractor shall remove all temporary systems.

If contract is for addition to existing facility, Contractor may, with written permission of COUNTY, use COUNTY's existing utilities by making prearranged payments to COUNTY for utilities used by Contractor for construction.

(b) Contractor shall not be assessed damages for delay in completion of the project when such delay was caused by the failure of the awarding authority of this contract or the owner of the utility to provide for removal or relocation of the existing main or trunkline utility facilities; however, when the Contractor is aware that removal or relocation of an existing utility has not been provided for, Contractor shall promptly notify the awarding authority and the utility in writing, so that provision for such removal or relocation may be made to avoid and minimize any delay which might be caused by the failure to remove or relocate the main or trunk line utility facilities, or to provide for its removal or relocation.

In accordance with section 4215 of the Government Code, if the Contractor, while performing the contract, discovers any existing main or trunkline utility facilities not identified by the public agency in the contract plans or specifications, Contractor shall immediately notify the public agency and utility in writing. The public utility, where they are the owner, shall have the sole discretion to perform repairs or relocation work at a reasonable price. The Contractor shall be compensated for the costs of locating and repairing damage not due to the failure of the Contractor to exercise reasonable care, and removing or relocating such utility facilities not indicated in the plans and specification with reasonable accuracy and for equipment on the project necessarily idled during such work. Such compensation shall be in accordance with the extra work provisions set out at Article 37 hereof.

#### **Article 44. SANITARY FACILITIES**

Contractor shall provide a sanitary, temporary, portable toilet facility as directed by the



COUNTY and its representative for the use of all workers. The building shall be maintained in a sanitary condition at all times, and shall be left at the site until removal is directed by the COUNTY and its representative.

#### **Article 45. TRENCHES**

(a) Trenching Requirements – Four Feet (4') Below the Surface. In the event the Project involves digging trenches or other excavations that extend deeper than four feet (4') below the surface, Contractor shall:

- (1) Promptly, and before the following conditions are disturbed, notify COUNTY, in writing, of any:
  - (A) Material that Contractor believes may be material that is hazardous waste, as defined in Health & Safety Code section 25117, that is required to be removed to a Class I, Class II, or Class III disposal site in accordance with provisions of existing law;
  - (B) Subsurface or latent physical conditions at the site differing from those indicated by information about the site made available to bidders prior to the deadline for submitting bids; and
  - (C) Unknown physical conditions at the site of any unusual nature, different materially from those ordinarily encountered and generally recognized as inherent in work of the character provided for in the Agreement.
- (2) In response to any written notice generated pursuant to paragraph (a) above, COUNTY shall promptly investigate the conditions, and if it finds that the conditions do materially so differ, or do involve hazardous waste, and cause a decrease or increase in Contractor's cost of, or the time required for, performance of any part of the Work, shall issue a change order under the procedures described in paragraph 37 of the General Conditions.
- (3) In the event that a dispute arises between COUNTY and Contractor whether the conditions materially differ, or involve hazardous waste, or cause a decrease or increase in Contractor's cost of, or time required for, performance of any part of the Work, Contractor shall not be excused from any scheduled completion date provided for by this Agreement, but shall proceed with all Work to be performed under this Agreement. Contractor shall retain any and all rights provided either by contract or by law which pertain to the resolution of disputes and protests between the Parties.

(b) Trenching Requirements – Project in Excess of Twenty-Five Thousand Dollars (\$25,000) and Five Feet (5') Below the Surface. For projects involving both an estimated expenditure in excess of twenty-five thousand dollars (\$25,000) and the excavation of any trench five feet (5') or more in depth, Contractor shall submit a detailed plan showing the design of shoring, bracing, sloping or other provisions to be made for worker protection from the hazard of caving ground during the excavation of such trench. The plan must be accepted by COUNTY (or by a registered civil or structural engineer, employed by COUNTY, to whom authority to accept has been delegated) in advance of excavation. If such plan varies from the shoring system standards, the plan shall be prepared by a registered civil or structural engineer. Nothing in this paragraph shall

allow Contractor to use a shoring, sloping, or protective system less effective than that required by California Construction Safety Orders. Further, nothing in this paragraph shall be construed to impose tort liability on COUNTY or any of its employees.

#### **Article 46. PROTECTION OF WORK AND PROPERTY**

Contractor shall be responsible for all damages to persons or property that occur as a result of Contractor's fault or negligence in connection with the prosecution of this contract, and shall be responsible for the proper care and protection of all materials delivered and work performed until completion and final acceptance by COUNTY. All work shall be solely at Contractor's risk. Contractor shall adequately protect adjacent property from settlement or loss of lateral support as provided by law and contract documents. Contractor shall take all necessary precautions for safety of employees on the work, and shall comply with all applicable safety laws and building codes to prevent accidents or injury to persons on; about or adjacent to premises where work is being performed. Contractor shall erect and properly maintain, at all times, as required by conditions and progress of work, all necessary safeguards, signs, barriers, lights and watchmen for protection of workers and the public, and shall post danger signs warning against hazards created by such features in the course of construction. Contractor shall designate a responsible member of its organization on the work, whose duty shall be prevention of accidents. Name and position of person so designated shall be reported to COUNTY by Contractor.

In an emergency affecting safety of life or of work or of adjoining property, Contractor, without special instruction or authorization from COUNTY and its representative, is hereby permitted to act, at Contractor's discretion, to prevent such threatened loss or injury, and Contractor shall so act, without appeal, if so authorized or instructed by COUNTY and its representative. Any compensation claimed by Contractor on account of emergency work shall be determined by agreement.

Contractor shall provide such heat, covering, and enclosures as are necessary to protect all work, materials, equipment, appliances, and tools against damage by weather conditions. Contractor shall take adequate precautions to protect existing sidewalks, curbs, pavements, utilities, adjoining property and structures, and to avoid damage thereto, and repair any damage thereto caused by construction operations.

Contractor shall:

- (1) Enclose working area with a substantial dust reducing barrier and public safety barricade, and arrange work to cause minimum amount of inconvenience to public and COUNTY Staff in their regular business activities.
- (2) Provide substantial barricades around any shrubs or trees indicated to be preserved.
- (3) Deliver materials to building area over route designated by Architect.
- (4) When directed by COUNTY, take preventative measures to eliminate objectionable dust.
- (5) Confine Contractor's apparatus, the storage of materials, and the operations of workers to limits indicated by law, ordinances, permits or directions of Architect, and shall not unreasonably encumber premises with materials, and enforce all

instructions of COUNTY and Architect regarding signs, advertising, fires, danger signals, barricades and smoking, and require that all persons employed on work comply with all regulations while on construction site. Hazardous materials of any kind are not allowed on site, without prior written approval from COUNTY.

- (6) Take care to prevent disturbing or covering any survey markers, monuments, or other devices marking property boundaries or corners. If such markers are disturbed by accident, they shall be replaced by an approved civil engineer at no cost to COUNTY.

#### **Article 47. LAY OUT AND FIELD ENGINEERING**

All field engineering required for laying out Contractor's work and establishing grades for earthwork operations shall be furnished by Contractor at Contractor's expenses. Such work shall be done by a qualified civil engineer approved by Architect/Engineer. Any required "As-Built" drawings of site development shall be prepared by the approved civil engineer.

#### **Article 48. CUTTING AND PATCHING**

Contractor shall do all cutting, fitting, or patching of work as required to make its several parts come together properly and fit it to receive or received by work of other Contractors showing upon, or reasonably implied by, the drawings and specifications for the completed structure, and Contractor shall make good after them as Architect/Engineer may direct. Contractor shall not endanger any work by cutting, excavating or otherwise altering work, and shall not cut or alter work of any other Contractor save with consent of Architect/Engineer.

#### **Article 49. CLEANING UP**

Contractor at all times shall keep premises free from debris such as waste, rubbish, and excess materials and equipment caused by work; debris shall be removed from premises. Contractor shall not leave debris under, in or about the premises. Upon completion of work, Contractor shall clean any areas where debris has collected. Contractor shall remove temporary fencing, barricades, and any temporary facilities from site.

#### **Article 50. CORRECTION OF WORK**

Contractor shall promptly remove from premises all work determined by COUNTY as failing to conform to contract, whether incorporated or not. Contractor shall promptly replace and re-execute his own work to comply with contract documents without additional expense to COUNTY, and shall bear the expense of making good all work of other Contractors destroyed or damaged by such removal or replacement.

If Contractor does not remove such work and materials within a reasonable time, fixed by written notice, COUNTY may remove the work and materials and may store the material at Contractor's expense. If Contractor does not pay expenses of such removal within ten (10) days' time thereafter, COUNTY may liquidate such work and materials upon private sale, and shall account for net proceeds thereof, after deducting all costs and expenses that should have been borne by Contractor.

#### **Article 51. ACCESS TO WORK**

COUNTY and its representative shall at all times have access to work wherever it is in preparation or progress. Contractor shall provide safe and proper facilities for such access so that COUNTY's representative may perform their functions under contract.

**Article 52. OCCUPANCY**

COUNTY reserves the right to occupy buildings at any time before completion, and such occupancy shall not constitute final acceptance of any part of work covered by this contract.

**Article 53. COUNTY'S INSPECTOR**

COUNTY may assign a representative to oversee work. Such representative shall have access to Inspector's Field Office and shall be fully informed of all progress and manner of work and character of materials. Representative shall have authority to stop work whenever provisions of the contract documents are not being complied with and Contractor shall instruct Contractor's employees accordingly.

All work shall be under observation of said COUNTY and its representative. Such personnel shall have free access to any or all parts of work at any time. Contractor shall furnish COUNTY and its representative reasonable facilities "Inspector's Field Office" for obtaining such information as may be necessary to keep COUNTY and its representative fully informed respecting progress and manner of work and character of materials. Inspection of work shall not relieve Contractor from any obligation to fulfill Contractor's contract. COUNTY and its representative shall have authority to stop work whenever provisions of contract documents are not being complied with, and Contractor shall instruct Contractor's employees accordingly.

**Article 54. TESTS AND INSPECTIONS**

If contract, COUNTY's instructions, laws, ordinances or any public authority require any work to be specially tested or approved, Contractor shall give notice in accordance with such authority of its readiness for observation or inspection at least two (2) working days prior to being tested or covered up. If inspection is by authority other than COUNTY, Contractor shall inform COUNTY of the date fixed for such inspection. Required certificates of inspection shall be secured by Contractor. Observations by COUNTY, its representative and other public authority shall be promptly made, and where practicable, at source of supply. If any work should be covered up without approval or consent of COUNTY, its representative and public authority, it must, if required by COUNTY, its representative and public authority, be uncovered for examination and satisfactorily reconstruction at Contractor's expenses in compliance with contract.

Costs of tests of any material found to be not in compliance with contract shall be paid for by Contractor.

See Comprehensive Specifications for materials to be tested.

Where such inspection and testing are to be conducted by an independent laboratory or agency, such materials or samples of materials to be tested shall be selected by such laboratory or agency or COUNTY's representative, and not by Contractor.

Contractor shall notify COUNTY a sufficient time in advance of manufacture of materials to be supplied by Contractor under contract which must by terms of contract be tested, in order that COUNTY may arrange for testing of same at source of supply. Any materials shipped by Contractor from source of supply prior to having satisfactorily passed such testing and

inspection, or prior to receipt of notice from said representative that such testing and inspection will not be required, shall not be incorporated in work without prior approval of COUNTY and subsequent testing and inspection.

Re-examination of questioned work may be ordered by COUNTY, and, if so ordered, work must be uncovered by Contractor. If such work be found in accordance with contract documents, COUNTY shall pay costs of re-examination and replacement. If such work be found not in accordance with contract documents, Contractor shall pay such costs.

**Article 55. SOILS INVESTIGATION REPORT**

When a soils investigation report obtained from test holes in site is available, such report shall not be part of this contract. Any information obtained from such report or any information given on drawings as to subsurface soil condition or to elevations of existing grades or elevations of underlying rock is approximate only and is not guaranteed, and does not form a part of the contract. Contractor is required to make a visual examination of site, and must make whatever tests Contractor deems appropriate to determine underground condition of soil. Contractor agrees that it will make no claim against COUNTY for damages in the event that, during progress of the work, Contractor encounters subsurface or latent conditions at site materially differing from those shown on drawings or indicated in specifications, or for unknown conditions of an unusual nature which differ materially from those ordinarily encountered and generally recognized as inherent in the work of the character provided for in plans and specifications.

**Article 56. ARCHITECT/ENGINEER'S AND CONSTRUCTION MANAGER'S STATUS**

The construction manager shall be COUNTY's representative during the construction period, and shall observe the progress and quality of the work on behalf of COUNTY. The construction manager shall have the authority to act on behalf of COUNTY only to the extent expressly provided in the contract documents. The construction manager shall have authority to stop work whenever such stoppage may be necessary in construction manager's reasonable opinion to insure the proper execution of the contracts.

The Architect/Engineer shall be, in the first instance, the judge of compliance with the design intent of the contract documents.

**Article 57. INDEMNITIES**

(a) Contractor agrees to the fullest extent permitted by law to indemnify, defend, protect, and hold COUNTY and its representatives, officers, directors, designees, employees, agents, successors, and assigns harmless from any and all claims, expenses, liabilities, causes of action, demands, losses, penalties, attorney's fees and costs, in law or equity, of every kind and nature whatsoever arising out of or in connection with Contractor's negligent acts and omissions or willful misconduct under this Agreement ("Claims"), whether or not arising from the passive negligence of COUNTY, but does not include Claims that are finally determined to be the result of the sole negligence or willful misconduct of COUNTY.

(b) Contractor agrees to defend with counsel acceptable to COUNTY, indemnify and hold COUNTY harmless from all Claims, including but not limited to:

(1) Personal injury, including but not limited to bodily injury, emotional injury, sickness

or disease or death to persons including but not limited to COUNTY's representatives, officers, directors, designees, employees, agents, successors and assigns, subcontractors and other third parties and/or damage to property of anyone (including loss of use thereof) arising out of Contractor's negligent performance of, or willful misconduct surrounding, any of the terms contained in this Agreement, or anyone directly or indirectly employed by Contractor or anyone for whose acts Contractor may be liable;

- (2) Liability arising from injuries to Contractor and/or any of Contractor's employees or agents arising out of Contractor's negligent performance of, or willful misconduct surrounding, any of the terms contained in this Agreement, or anyone directly or indirectly employed by Contractor or anyone for whose acts Contractor may be liable;
- (3) Penalties imposed upon account of the violation of any law, order, citation, rule, regulation, standard, ordinance or statute caused by the negligent action or inaction, or willful misconduct of Contractor or anyone directly or indirectly employed by Contractor or anyone for whose acts Contractor may be liable;
- (4) Infringement of any patent rights which may be brought against COUNTY arising out of Contractor's work;
- (5) Any violation or infraction by Contractor of any law, order, citation, rule, regulation, standard, ordinance or statute in any way relating to the occupational health or safety of employees; and
- (6) Any breach by Contractor of the terms, requirements or covenants of this Agreement.

- (c) The indemnification provisions of Paragraphs 57(b)(1) through 57(b)(6) above shall extend to Claims occurring after this Agreement is terminated, as well as while it is in force.

**Article 58. PROVISIONS REQUIRED BY LAW DEEMED INSERTED**

Each and every provision of law and clause required by law to be inserted in the contract shall be deemed to be inserted herein, and the contract shall be read and enforced as though it were included herein, and if, through mistake or otherwise, any such provision is not inserted, or is not correctly inserted, then upon application of either party, the contract shall forthwith be physically amended to make such insertion or correction.

**Article 59. LABOR - EMPLOYMENT SAFETY**

Contractor shall maintain emergency first aide treatment for Contractor's employees which complies with the Federal Occupational Safety and Health Act of 1970 (29 U.S.C.A. 651, *et seq.*).

**Article 60. NOTICE OF TAXABLE POSSESSORY INTEREST**

The terms of this document may result in the creation of a possessory interest. If such a possessory interest is vested in a private party to this document, the private party may be subjected to the payment of personal property taxes levied on such interest.

**Article 61. ASSIGNMENT OF UNFAIR BUSINESS PRACTICES CLAIMS (CLAYTON ACT AND CARTWRIGHT ACT)**

Bidder shall comply with the following:

*“In entering into a public works contract or a subcontract to supply goods, services or materials pursuant to a public works contract, the contractor or subcontractor offers and agrees to assign to the awarding body all rights, title and interest in and to all causes of action it may have under Section 4 of the Clayton Act (15 U.S.C. sec. 15) or under the Cartwright Act (Chapter 2 commencing with Section 16700) of Part 2 of Division 7 of the Business and Professions Code), arising from purchases of goods, services, or materials pursuant to the public works contract or the subcontract. This assignment shall be made and become effective at the time the awarding body tenders final payment to the contractor, without further acknowledgment by the parties.” Cal Pub Contract Code § 7103.5(b)*

**Article 62. SUBSTITUTION OF SECURITY**

Upon Contractor’s request, COUNTY will make payment of funds withheld from progress payments to ensure performance under the contract pursuant to the requirements of California Public Contracts Code, section 22300, if the Contractor deposits in escrow with COUNTY, or with a bank acceptable to COUNTY, securities eligible for investment under Government Code section 16430 or bank savings and loan certificates of deposit, subject to the following conditions:

- (a) Contractor shall bear the expense of COUNTY and the escrow agent, and COUNTY and the bank, in connection with the escrow deposit made.
- (b) Securities or certificates of deposit to be placed in escrow shall be of a value at least equivalent to the amount of retention to be paid to the Contractor pursuant to this Article.
- (c) Contractor shall enter into an escrow agreement satisfactory to COUNTY, which agreement shall include provisions governing, inter alias:
  - (1) the amount of securities to be deposited,
  - (2) the providing of powers of attorney or other documents necessary for the transfer of the securities to be deposited,
  - (3) conversion of cash to provide funds to meet defaults by Contractor including, but not limited to, termination of Contractor’s control over the work, stop notice filed pursuant to law or other amounts to be kept or retained under the provisions of the contract,
  - (4) decrease in value of securities on deposit,
  - (5) the termination of the escrow upon completion of the contract.
- (d) Contractor shall obtain the written consent of the surety to such agreement.

**Article 63. NON-DISCRIMINATION AND DISADVANTAGED BUSINESS ENTERPRISE PROGRAM**

- (a) During the performance of this Agreement, Contractor and its subcontractors shall not unlawfully discriminate, harass or allow harassment against any employee or applicant for employment because of sex, race, color, ancestry, religious creed, national origin, physical disability (including HIV and AIDS), mental disability, medical condition



(cancer), age (over forty (40)), marital status and denial of family care leave. Contractor and its subcontractors shall insure that the evaluation and treatment of their employees and applicants for employment are free from such discrimination and harassment. Contractor and its subcontractors shall comply with the provisions of the Fair Employment and Housing Act (Gov. Code section 12990 (a-f) *et seq.*) and the applicable regulations promulgated thereunder (California Code of Regulations, Title 2, Section 7285 *et seq.*). The applicable regulations of the Fair Employment and Housing Commission implementing Government Code section 12990 (a-f), set forth in Chapter 5 of Division 4 of Title 2 of the California Code of Regulations, are incorporated into this Agreement by reference and made a part hereof as if set forth in full. The applicable regulations of Section 504 of the Rehabilitation Act of 1973 (29 U.S.C. section 794 (a)) are incorporated into this Agreement by reference and made a part hereof as if set forth in full. Contractor and its subcontractors shall give written notice of their obligations under this clause to labor organizations with which they have a collective bargaining or other agreement. Contractor shall include the nondiscrimination and compliance provisions of this clause in all subcontracts to perform Work under this Agreement.

- (b) Contractor and its subcontractors shall reference and abide by the guidance and Disadvantaged Business Enterprise specifications contained in the California Department of Transportation's Local Programs Procedures 06-01 (which has been approved and released at <http://www.dot.ca.gov/> when working pursuant to this Agreement.

#### **Article 64. SPECIAL CONDITIONS**

- (a) The work shall be commenced on the date stated in COUNTY's *Notice to the Contractor to Proceed* which date will not be greater than ten (10) consecutive calendar days from and after the date of execution of the contract, and shall be completed within **ten (10) working** days from and after the date stated in such notice. (See Article 2 of *Agreement* and Article 6 of *General Conditions*.)
- (b) The number of copies of drawings and specifications to be furnished to Contractor free of charge, per Article 3 of the *General Conditions* is three (3).
- (c) The number of executed copies of the *Agreement*, the *Performance Bond*, and the *Payment Bond* for the *Public Works* required is six (6).

#### **Article 65. CONTRACT CONSTRUCTION**

This contract has been reviewed by legal counsel for both COUNTY and Contractor, and no presumption or rule that ambiguities shall be construed against the drafting party shall apply to the interpretation or enforcement of this contract and/or any and all amendments thereto.

#### **Article 66. COGNIZANCE OF VIOLATIONS BY COUNTY**

- (a) Contractor understands and agrees that COUNTY shall take cognizance of violations of Chapter 1 of Part 7 of Division 2 of the California Labor Code committed in the course of the execution of this Agreement, and shall promptly report any suspected violations to the Labor Commissioner.
- (b) If COUNTY determines as a result of its own investigation that there has been a violation of Chapter 1 of Part 7 of Division 2 of the California Labor Code and withholds payment

to Contractor, the procedures in California Labor Code section 1771.6 shall be followed.

- (c) COUNTY may bring an action in a court of competent jurisdiction to recover from Contractor the difference between the wages actually paid to an employee and the wages that were required to be paid to an employee pursuant to Chapter 1 of Part 7 of Division 2 of the California Labor Code, any penalties required to be paid pursuant to Chapter 1 of Part 7 of Division 2 of the California Labor Code, and costs and attorney's fees related to the action, if either of the following is true:
  - (1) COUNTY previously affirmatively represented to Contractor in writing, in the call for bids, or otherwise, that the Work was not a "public work," as defined in Chapter 1 of Part 7 of Division 2 of the California Labor Code; or
  - (2) COUNTY received actual written notice from the Department of Industrial Relations that the Work is a "public work," as defined in Chapter 1 of Part 7 of Division 2 of the California Labor Code, and failed to disclose that information to Contractor before the bid opening or award.

#### **Article 67. LABOR STANDARDS COMPLIANCE REQUIREMENTS**

- (a) It is Contractor's responsibility to provide all labor compliance documentation from its subcontractors completely and accurately in a timely manner. Contractor is responsible to review promptly and then forward on all required documentation to COUNTY per the time schedules in the Labor Compliance Handout. Included with the Labor Compliance Handout, COUNTY will provide training, documentation requirements, forms, etc., at the preconstruction conference or at a time designated by COUNTY.

For those Public Works Projects that are subject to the State Department of Industrial Relations (DIR), Division of Labor Standards Enforcement (DLSE) compliance monitoring and enforcement it is the Contractor's responsibility to submit certified payroll records directly to the state Compliance Monitoring Unit (CMU). More information concerning state compliance can be found at <https://www.dir.ca.gov/Public-Works/publicworks.html>. The responsibility for compliance with these provisions is fixed with the Contractor.

- (b) In the event, during the review process of labor compliance documentation from COUNTY's labor compliance monitor, inaccurate, missing or incomplete information was provided, the labor compliance monitor will request from Contractor the items, revisions and documentation needed. The cost of this additional labor compliance enforcement shall be borne by Contractor.

#### **Article 68. CONFLICT OF INTEREST AND GRATUITIES**

- (a) Contractor agrees that it presently has no interest and shall not acquire any interest, direct or indirect, which could conflict in any manner or degree with the performance of services required to be performed under this Agreement. Contractor further agrees that in the performance of this Agreement, no person having any such interest shall be employed.
- (b) Contractor agrees to designate such person or persons who have responsibility for carrying out the services under this Agreement and that such person or persons as may

be designated shall take any and all actions necessary to comply with COUNTY's Conflict of Interest Code adopted pursuant to California Government Code section 81000 to the extent required thereunder.

- (c) If it is found, after notice and hearing by COUNTY, that gratuities (in the form of entertainment, gifts, or otherwise) were offered or given by Contractor, or any agent or representative of Contractor, to any officer, employee or agent of COUNTY with a view toward securing a contract or securing favorable treatment with respect to the awarding or amending or the making of any determinations with respect to the performance of this Agreement, COUNTY may, by written notice to Contractor, terminate the right of Contractor to proceed under this Agreement and/or may pursue such other rights and remedies provided by law or under this Agreement.
- (d) In the event this Agreement is terminated as provided herein, COUNTY shall be entitled (1) to pursue the same remedies against Contractor as it could pursue in the event of a breach of the Agreement by Contractor, and (2) as a penalty in addition to any other damages to which it may be entitled by law, to exemplary damages in an amount (as determined by COUNTY) which shall be not less than three (3) nor more than ten (10) times the costs incurred by Contractor in providing any such gratuities to any such officer, employee or agent.

#### **Article 69. FEDERAL CONTRACT REQUIREMENTS**

##### **(a) Signage Requirements.**

- (1) **Project Identity Signage.** Contractor is required to provide and install the required project identity signage as detailed in the Plans and Specifications, in the size and at the location indicated by the Director of Public Works or his/her designee, and to maintain the signage in good condition for the duration of the Project. The signage may not be removed until the Notice of Completion is recorded or by written direction of the Director of Public Works or his/her designee.
  - (2) **Required Employee Signage and Posters.** Contractor is required to provide and install the Federal and State required employee posters and the required material pertaining to the required labor standards provisions are posted (including, but not limited to, WH-1321, OSHA 3165 and OFCCP-English, EFCCP-Spanish) at the worksite in a prominent and accessible place.
  - (3) **Section 3 Compliant Signage.** If required by COUNTY, Contractor is directed to provide and install the "Offer for Employment" signage as detailed in the Plans and Specifications in the size and at the location indicated by the Director of Public Works or his/her designee and to maintain the signage in good condition for the duration of the Project. The signage may not be removed until the Notice of Completion is recorded or by written direction of the Director of Public Works or his/her designee.
- (b) **Housing And Urban Development Act Compliance.** When applicable, Contractor agrees to comply with Section 3 of the Housing and Urban Development Act of 1968 (42 U.S.C. 3601 *et seq.*) which provides that to the greatest extent feasible, Contractor shall provide job training, employment and contracting opportunities for low- or very-low

income residents in connection with the Project. The responsibility for compliance with these provisions is fixed with Contractor.

- (c) Copeland “Anti-Kickback” Act Compliance. When applicable, Contractor agrees to comply with the Copeland Act (18 USC §874 and 40 USC §276c; 29 CFR Part 3) which precludes Contractor and its subcontractors from in any way inducing an employee to give up any part of the compensation to which he or she is entitled under his or her contract of employment. Contractor and its subcontractors shall submit a weekly statement of the wages paid to each employee performing on covered work during the preceding payroll period. Contractor understands and agrees that should Contractor its subcontractors induce an employee working on a covered contract to give up any part of the compensation to which he or she is entitled, the inducing party may be subject to a five thousand dollar (\$5,000) fine, or imprisonment for up to five (5) years, or both. Contractor also understands and agrees that willful falsification of the statement of compliance may subject the employer to civil or criminal prosecution and may be cause for contract termination or debarment. The responsibility for compliance with these provisions is fixed with Contractor.
- (d) Fair Labor Standards Act Compliance. When applicable, Contractor agrees to comply with the Fair Labor Standards Act of 1938 as amended (29 U.S.C. 201 *et seq.*) which establishes minimum wage, overtime pay, recordkeeping, and youth employment standards affecting full-time and part-time workers on the Project. The responsibility for compliance with these provisions is fixed with Contractor.
- (e) Certification Regarding Debarment, Suspension and Other Responsibility Matters. When applicable, Contractor agrees to execute a certification regarding debarment, suspension and other responsibility matters. The responsibility for compliance with this provision is fixed with Contractor.
- (f) Federal Equal Employment Opportunity Construction Contract Specifications. When applicable, Contractor agrees to incorporate the notice set forth in paragraph (d) of 41 C.F.R. 60-4.2 relating to the “Equal Opportunity Clause” and the “Standard Federal Equal Employment Specifications.” The responsibility for compliance with this provision is fixed with Contractor.
- (g) Clean Air Act and the Federal Water Pollution Control Act. When applicable, Contractor agrees to comply with all applicable standards, orders or regulations issued pursuant to the Clean Air Act (42 U.S.C. 7401 *et seq.*), the Federal Water Pollution Control Act as amended (33 U.S.C. 1251 *et seq.*), Presidential Executive Order 11738 and Environmental Protection Agency regulations set forth at 40 C.F.R. Part 15. Contractor understands and agrees that violations shall be reported to the Federal awarding agency and the Regional Office of the Environmental Protection Agency. The responsibility for compliance with these provisions is fixed with Contractor.
- (h) Prohibition on the Use of Federal Funds for Lobbying. When applicable, Contractor shall file the required certification. Each tier certifies to the tier above that it will not and has not used Federal appropriated funds to pay any person or organization for influencing or attempting to influence an officer or employee of any agency, a member

of Congress, officer or employee of Congress, or an employee of a member of Congress in connection with obtaining any Federal contract, grant or any other award covered by 31 U.S.C. 1352. Each tier shall also disclose any lobbying with non-Federal funds that takes place in connection with obtaining any Federal award. Such disclosures are forwarded from tier to tier up to the recipient. The responsibility for compliance with this provision is fixed with Contractor.

- (i) Federal Employment Eligibility Verification. Contractor shall verify name, date of birth and social security number, along with immigration information for non-citizens in order to verify the identity and employment eligibility of both citizen and non-citizen new hires. The responsibility for compliance with this provision is fixed with Contractor.
- (j) The Civil Rights, HCD and Age Discrimination Act Assurances. During the performance of this Agreement, Contractor assures that no otherwise qualified person shall be excluded from participation or employment, denied program benefits or be subjected to discrimination based on race, color, national origin, gender, age or handicap, under any program or activity funded by this Agreement, as required by Title VI of the Civil Rights Act of 1964, Title I of the Housing and Community Development Act of 1974, as amended, and the Age Discrimination Act of 1975, and all implementing regulations. The responsibility for compliance with these provisions is fixed with Contractor.
- (k) Standard Equal Opportunity Clause.
  - (1) Contractor hereby agrees that it will incorporate or cause to be incorporated into any contract for construction work, or modification thereof, as defined in the regulations of the Secretary of Labor at 41 CFR Chapter 60, which is paid for in whole or in part with funds obtained from the Federal Government or borrowed on the credit of the Federal Government pursuant to a grant, contract, loan insurance, or guarantee, or undertaken pursuant to any Federal program involving such grant, contract, loan, insurance, or guarantee, the following equal opportunity clause:

“During the performance of this contract, the Contractor agrees as follows:

- (A) The Contractor will not discriminate against any employee or applicant for employment because of race, color, religion, sex, national origin or disabilities. The Contractor will take affirmative action to ensure that applicants are employed, and that employees are treated during employment without regard to their race, color, religion, sex, or national origin. Such action shall include, but not be limited to, the following: employment, upgrading, demotion or transfer; recruitment or recruitment advertising; layoff or termination; rates of pay or other forms of compensation; and selection for training, including apprenticeship. The Contractor agrees to post in conspicuous places, available to employees and applicants for employment, notices to be provided setting forth the provisions of this nondiscrimination clause.
- (B) The Contractor will, in all solicitations or advertisements for employees placed by or on behalf of the Contractor, state that all qualified applicants will receive consideration for employment without regard to race, color,

religion, sex, national origin or disabilities.

- (C) The Contractor will send to each labor union or representative of workers with which the Contractor has a collective bargaining agreement or other contract or understanding, a notice to be provided advising the said labor union or workers' representatives of the Contractor's commitments under this section, and shall post copies of the notice in conspicuous places available to employees and applicants for employment.
  - (D) The Contractor will comply with all provisions of Executive Order 11246 of September 24, 1965, and of the rules, regulations, and relevant orders of the Secretary of Labor.
  - (E) The Contractor will furnish all information and reports required by Executive Order 11246 of September 24, 1965, and by rules, regulations, and orders of the Secretary of Labor, or pursuant thereto, and will permit access to its books, records, and accounts by the administering agency and the Secretary of Labor for purposes of investigation to ascertain compliance with such rules, regulations, and orders.
  - (F) In the event of the Contractor's noncompliance with the discrimination clauses of this contract or with any of the said rules, regulations, or orders, this contract may be canceled, terminated, or suspended in whole or in part and the Contractor may be declared ineligible for further government contracts or federally assisted construction contracts in accordance with procedures authorized in Executive Order 11246 of September 24, 1965, and such other sanctions may be imposed and remedies invoked as provided in Executive Order 11246 of September 24, 1965, or by rules, regulations, or orders of the Secretary of Labor, or as otherwise provided by law.
  - (G) The Contractor will include the portion of the sentence immediately preceding paragraph "1" and the provisions of paragraphs "1" through "7" in every contract or purchase order unless exempted by rules, regulations, or orders of the Secretary of Labor issued pursuant to Section 504 of Executive Order 11246 of September 24, 1965, so that such provisions will be binding upon each contractor or vendor. The Contractor will take such action with respect to any contract or purchase order as the administering agency may direct as a means of enforcing such provisions, including sanctions for noncompliance; provided, however, that in the event a Contractor becomes involved in, or is threatened with, litigation with a contractor or vendor as a result of such direction by the administering agency, the Contractor may request the United States to enter into such litigation to protect the interests of the United States."
- (1) Contractor further agrees that it will be bound by the above equal opportunity clause with respect to its own employment practices when it participates in federally-assisted construction work; provided that if Contractor so participating is a State or local government, the above equal opportunity

clause is not applicable to any agency, instrumentality, or subdivision of such government which does not participate in work on or under the Agreement.

- (2) Contractor agrees that it will assist and cooperate actively with the administering agency and the Secretary of Labor in obtaining the compliance of Contractors and subcontractors with the equal opportunity clause and the rules, regulations, and relevant orders of the Secretary of Labor, that it will furnish the Department and HUD and the Secretary of Labor such information as they may require for the supervision of such compliance, and that it will otherwise assist the administering agency in the discharge of the agency's primary responsibility for securing compliance.
- (3) Contractor further agrees that it will refrain from entering into any contract or contract modification subject to Executive Order 11246 of September 24, 1965, with a contractor debarred from, or who has not demonstrated eligibility for, government contracts and federally-assisted construction contracts, pursuant to the Executive Order and will carry out such sanctions and penalties for violation of the equal opportunity clause as may be imposed upon contractors and subcontractors by the administering agency or the Secretary of Labor pursuant to Part II, Subpart D of the Executive Order. In addition, Contractor agrees that if it fails or refuses to comply with these undertakings, COUNTY may take any or all of the following actions: Cancel, terminate, or suspend in whole or in part this funding commitment (contract, loan, grant, insurance, guarantee); refrain from extending any further assistance to the applicant under the program with respect to which the failure or refund occurred until satisfactory assurance of future compliance has been received from such Contractor; and refer the case to the Department of Justice for appropriate legal proceedings.

#### **Article 70. INELIGIBILITY**

If the Bidder has been deemed ineligible to perform work on public works projects pursuant to Labor Code Sections 1777.1 or 1777.7, then it shall be prohibited from bidding on, being awarded a contract for, or performing work as a subcontractor on this project, or any other public works project within the state of California.

#### **Article 71. RESOLUTION OF CLAIMS**

- (a) Compliance with all change order procedures is a prerequisite to filing a Public Contract Code Claim pursuant to this Section. Claims must be submitted no later than (a) 30 days after the dispute resolution process set forth in Section 5-1.43 is complete or (b) 30 days after the occurrence of the event giving rise to the claim.
- (b) In accordance with the procedures set forth in Public Contract Code Sections 9204 and 20104-20104.6, a Contractor may submit a claim by registered or certified mail with return receipt requested for one or more of the following: (a) a time extension, including, without limitation, for relief from damages or penalties for delay assessed by the County; (b) payment by the County of money or damages arising from work done by, or on behalf of, the Contractor pursuant to this contract and payment for which is not otherwise expressly provided or to which the Contractor is not otherwise entitled; or (c) payment of an amount that is disputed by the County.



- (c) The Contractor shall furnish reasonable documentation to support the claim, including, but not limited to: 1) a clear concise recital of the basis upon which the claim is asserted, including a designation of the provisions of the Contract upon which the claim is based. 2) a statement as to the amount of time and/or compensation sought pursuant to the claim; 3) whether the Contractor's claim arises from an ongoing occurrence, and if so a description of the specific work activities affected by the claim, 4) a time impact analysis in the event that Contractor request a time extension, 5) full and complete cost records supporting the amount of any claim for additional compensation, and 6) a notarized certification by the Contractor as follows: "Under the penalty of law for perjury or falsification and with specific reference to the California False Claims Act. Government Code Section 12650 et seq. The undersigned hereby certifies that the information contained herein is a true, accurate and complete statement of all features relating to the claim asserted." Failure by the Contractor to provide sufficient documentation will result in denial of the claim. The County reserves the right to request additional documentation, or clarification of the documentation provided.
- (d) Upon receipt of a claim, the County will conduct a reasonable review and provide a written statement to the Contractor identifying what portion of the claim is disputed and what portion is undisputed within 45 days of receipt of the claim. The County and Contractor may, by mutual agreement, extend the 45 day time period. For any undisputed portion of a claim, the County must make payment within 60 days of its issuance of the written statement.
- (e) If the Contractor disputes the County's written statement, or if the County fails to respond, the Contractor may demand an informal conference to meet and confer for the settlement of the issues in dispute. The County will then schedule the meet and confer conference within 30 days of the demand. Within 10 business days following the meet and confer conference. The County will provide a written statement identifying the portion of the claim that remain in dispute. Any payment due on an undisputed portion of the claim will be made within 60 days of the meet and confer conference.
- (f) After the meet and confer conference, any disputed portion of the claim shall be submitted to non-binding mediation. Alternatively, upon receipt of a claim, the parties may mutually agree to waive in writing, mediation and proceed directly to the commencement of a civil action or binding arbitration as applicable, if mediation is unsuccessful, the parts of the claim that remain in dispute shall be subject to applicable procedures set forth below.
- (g) Failure of a public entity to respond to a claim within the time periods described above shall result in the claim being deemed rejected in its entirety. Additionally amounts not paid in a timely manner shall bear interest at 7 percent per year.
- (h) In the event that the mediation is unsuccessful, Contractor must file a government claim pursuant to Government Code Sections 910 et seq. in order to initiate a civil action.
- (i) In any civil action filed to resolve claims, the court shall submit the matter to nonbinding mediation within 60 days following the filing or responsive pleading provided that the parties have not already participated in mediation of the claim as outlined above. If the



matter remains in dispute after nonbinding mediation, the court shall submit the matter to judicial arbitration pursuant to the Code of Civil Procedure Section 1141.10 et. seq. If the matter remains in dispute after judicial arbitration, the County or the Contractor may request a trial de novo.

## **Article 72. MISCELLANEOUS**

- (a) Entire Agreement. This Agreement contains the entire agreement between COUNTY and Contractor relating to the transactions contemplated hereby and supersedes all prior or contemporaneous agreements, understandings, provisions, negotiations, representations, or statements, either written or verbal.
- (b) Assignment. Neither this Agreement nor any duties or obligations hereunder shall be assignable by Contractor without the prior written consent of COUNTY.
- (c) Modification. No modification, waiver, amendment, discharge, or change of this Agreement shall be valid unless the same is in writing and signed by the Party against whom the enforcement of such modification, waiver, amendment, discharge, or change is or may be sought.
- (d) Captions. Captions in this Agreement are inserted for convenience of reference only and do not define, describe, or limit the scope or the intent of this Agreement or any of the terms thereof.
- (e) Partial Invalidity. If any provision in this Agreement is held by a court of competent jurisdiction to be invalid, void, or unenforceable, the remaining provisions will nevertheless continue in full force without being impaired or invalidated in any way.
- (f) Gender and Interpretation of Terms and Provisions. As used in this Agreement and whenever required by the context thereof, each number, both singular and plural, shall include all numbers, and each gender shall include a gender. Contractor as used in this Agreement or in any other document referred to in or made a part of this Agreement shall likewise include singular and the plural, a corporation, a partnership, individual, firm, or person acting in any fiduciary capacity as executor, administrator, trustee or in any other representative capacity or any other entity. All covenants herein contained on the part of Contractor shall be joint and several if more than one person, firm or entity executes this Agreement.
- (g) Waiver. No waiver of any breach or of any of the covenants or conditions of this Agreement shall be construed to be a waiver of any other breach or to be consent to any further or succeeding breach of the same or any other covenant or condition.
- (h) Attorneys' Fees and Costs. If either Party herein brings an action to enforce the terms thereof or to declare rights hereunder, the prevailing Party in any such action, on trial or appeal, shall be entitled to reasonable attorneys' fees as fixed by the court and actual costs to be paid by the losing Party.
- (i) Authority.

- (1) Each individual executing this Agreement on behalf of Contractor represents and warrants that:
    - (A) He/She is duly authorized to execute and deliver this Agreement on behalf of Contractor;
    - (B) Such execution and delivery is in accordance with the terms of the Articles of Incorporation or Partnership, any by-laws or Resolutions of Contractor and;
    - (C) This Agreement is binding upon Contractor in accordance with its terms.
  - (2) Contractor shall deliver to COUNTY evidence acceptable to COUNTY of the foregoing within thirty days of execution of this Agreement.
- (j) Counterparts. This Agreement may be executed in counterparts.
- (k) Review of Agreement Terms. This Agreement has been reviewed and revised by legal counsel for both COUNTY and Contractor, and no presumption or rule that ambiguities shall be construed against the drafting Party shall apply to the interpretation or enforcement of the same or any subsequent amendments thereto.

## EXHIBIT A

### GENERAL NOTES AND SCOPE OF WORK

#### **IMPERIAL COUNTY BRAWLEY ROAD YARD REPLACEMENT 4736 STATE HWY-111, BRAWLEY, CA. 92227 COUNTY PROJECT NO. SR5901ADM**

#### **SCHEDULE:**

##### **Work Hours**

Monday-Friday between 6:00AM to 6:00PM per Article 19. Hours of Work

#### **SCOPE OF WORK:**

##### **Laws and Regulations**

Contractor shall comply with all applicable state and federal laws and regulations governing the safe clean-up, storage, collection, identification, handling, packaging, documentation, transfer, and disposal of hazardous waste. Contractor shall be responsible to be aware of the most updated changes to applicable laws and regulations.

##### **Site Excavation**

Areas identified in the site plan will be removed by approximately 36" below the building pad elevation or existing natural surface grade. The vertical and lateral extent of excavation areas will be based on the concentrations of lead found in the soils and the accessibility of such soils for the excavation identified in the attached Geotechnical Report (Pg. 12).

##### **Dust Control**

Dust control measures shall be implemented during soil excavation as required by the Air Pollution Control District Rule 801 for Construction and Earthmoving Activities. A rule of "no visible dust" shall be applied to all aspects of the work that involve soil excavation.

##### **Soil Segregation**

Contractor shall segregate excavated soils into contaminated and non-contaminated stockpiles, based on engineer's classification. Contractor shall provide all necessary materials required for proper separation, containerization, handling, storage, transport, and disposal of hazardous waste materials collected.

##### **Transportation and Disposal**

Contractor shall organize all hazardous materials for transport. Contractor shall containerize all hazardous wastes and prepare all such wastes for transport and disposal. Contractor shall dispose contaminated soil at an approved off-site facility. The contractor shall be responsible for any additional costs incurred due to excess weight caused by

increase in soil moisture content after the soil is excavated. Contractor shall remain aware of current costs and analytical requirements for disposal of hazardous wastes at approved California Department of Toxic Substances Control (DTSC)/Environmental Protection Agency (EPA) permitted disposal.

**Manifest**

Contractor shall manifest all hazardous waste lawfully and efficiently to the satisfaction of DTSC, California DOT, US DOT, EPA, and EPA permitted disposal facilities. All waste shall be transported under manifest using the County EPA generator identification number. Contractor shall provide copy of all manifests and bills of lading to County personnel prior to transporting hazardous waste from the site.

**EXHIBIT B**

**GEOTECHNICAL STUDY REPORT**

**IMPERIAL COUNTY BRAWLEY ROAD YARD REPLACEMENT  
4736 STATE HWY-111, BRAWLEY, CA. 92227  
COUNTY PROJECT NO. SR5901ADM**



## **Geotechnical Report**

# **ICPW Maintenance Building**

Brawley, California

---

Prepared for:

**Sanders, Inc.**

1102 Industry Way  
El Centro, CA 92243



---

Prepared by:



**Landmark Consultants, Inc.**  
780 N. 4<sup>th</sup> Street  
El Centro, CA 92243  
(760) 370-3000

**November 2016**



780 N. 4th Street  
El Centro, CA 92243  
(760) 370-3000  
(760) 337-8900 fax

77-948 Wildcat Drive  
Palm Desert, CA 92211  
(760) 360-0665  
(760) 360-0521 fax

November 29, 2016

Mr. Jesus Aguilera  
Sanders, Inc.  
1102 Industry Way  
El Centro, CA 92243

**Geotechnical Report  
ICPW Maintenance Building  
4736 Hwy 111  
Brawley, California  
LCI Report No. LE16213**

Dear Mr. Aguilera:

This geotechnical report is provided for design and construction of the proposed replacement of the existing maintenance building at the Imperial County Public Works (ICPW) Department facility located at 4736 Hwy 111 in northern Brawley, California. Our geotechnical exploration was conducted in response to your request for our services. The enclosed report describes our soil engineering site evaluation and presents our professional opinions regarding geotechnical conditions at the site to be considered in the design and construction of the project.

This executive summary presents *selected* elements of our findings and professional opinions. This summary *may not* present all details needed for the proper application of our findings and professional opinions. Our findings, professional opinions, and application options are *best related through reading the full report*, and are best evaluated with the active participation of the engineer of record who developed them. The findings of this study are summarized below:

- Clay soils (CH) of high expansion predominate the site. The near surface soils (upper 10 feet) had a hydrocarbon odor. ICPW personnel at the site indicated that an underground fuel storage tank was removed from the site and the excavation backfilled. Undocumented fill may be present at that location, possibly requiring deep removals.
- Foundation designs should mitigate expansive soil conditions by one of the following methods:
  1. Remove and replace upper 3.0 feet of clay soils with non-expansive sands.
  2. Design foundations to resist expansive forces in accordance with the 2013 California Building Code (CBC) Chapter 18, Section 1806. This requires grade-beam stiffened of floor slabs (17.5 feet maximum on center) or post-tensioned floor slabs. Design soil bearing pressure = 1,500 psf. Differential movement of 1.0 to 1.5 inches can be expected for slab on grade foundations placed on clay soils.
  3. A combination of the methods described above.



- The risk of liquefaction induced settlement is very low (estimated settlement of ½ inch at to 49 to 51.5 feet below ground surface. There is a very low risk of ground rupture should liquefaction occur.
- The clay soils are aggressive to concrete and steel. Concrete mixes shall have a maximum water cement ratio of 0.45 and a minimum compressive strength of 4,500 psi (minimum of 6.25 sacks Type V cement per cubic yard).
- All reinforcing bars, anchor bolts and hold down bolts shall have a minimum concrete cover of 3.0 inches unless epoxy coated (ASTM D3963/A934). Hold-down straps are not allowed at the foundation perimeter. No pressurized water lines are allowed below or within the foundations.
- Pavement structural sections should be designed for clay subgrade soils (R-Value = 5).

We did not encounter soil conditions that would preclude development of the proposed project provided the professional opinions contained in this report are considered in the design and construction of this project.

We appreciate the opportunity to provide our findings and professional opinions regarding geotechnical conditions at the site. Please provide our office with a set of the foundation plans and civil plans for review to insure that the geotechnical site constraints have been included in the design documents. If you have any questions or comments regarding our findings, please call our office at (760) 370-3000.

Respectfully Submitted,  
*Landmark Consultants, Inc.*



Steven K. Williams, PG, CEG  
Senior Engineering Geologist



Jeffrey O. Lyon, PE  
President



TABLE OF CONTENTS

	Page
Section 1.....	1
INTRODUCTION .....	1
1.1 Project Description.....	1
1.2 Purpose and Scope of Work.....	1
1.3 Authorization .....	2
Section 2.....	3
METHODS OF INVESTIGATION .....	3
2.1 Field Exploration .....	3
2.2 Laboratory Testing.....	4
Section 3.....	5
DISCUSSION.....	5
3.1 Site Conditions.....	5
3.2 Geologic Setting.....	5
3.3 Subsurface Soil .....	6
3.4 Groundwater .....	7
3.5 Faulting.....	7
3.6 General Ground Motion Analysis.....	8
3.7 Seismic and Other Hazards.....	9
3.8 Liquefaction .....	10
Section 4.....	12
DESIGN CRITERIA .....	12
4.1 Site Preparation.....	12
4.2 Utility Trench Backfill.....	14
4.3 Foundations and Settlements .....	15
4.4 Slabs-On-Grade.....	17
4.5 Concrete Mixes and Corrosivity .....	19
4.6 Excavations .....	21
4.7 Seismic Design.....	21
4.8 Pavements .....	21
Section 5.....	23
LIMITATIONS AND ADDITIONAL SERVICES .....	23
5.1 Limitations .....	23
5.2 Additional Services.....	24

## **Appendices**

APPENDIX A: Vicinity and Site Maps

APPENDIX B: Subsurface Soil Logs and Soil Key

APPENDIX C: Laboratory Test Results

APPENDIX D: Liquefaction Analysis

APPENDIX E: Pipe Bedding and Trench Backfill Recommendations

APPENDIX F: References

## Section 1

**INTRODUCTION****1.1 Project Description**

This report presents the findings of our geotechnical exploration and soil testing for the proposed replacement of the existing maintenance building at the Imperial County Public Works Department facility located at 4736 Hwy 111 in northern Brawley, California (See Vicinity Map, Plate A-1). The proposed development will consist of a 3,790 square foot pre-engineered metal building with a slab-on-grade foundation. A site plan for the proposed development was provided by the client at the time that this report was prepared.

The structure is planned to consist of a slab-on-grade foundation and steel-frame construction. Footing loads at exterior bearing walls are estimated at 0.5 to 3 kips per lineal foot. Column loads are estimated to range from 5 to 30 kips. If structural loads exceed those stated above, we should be notified so we may evaluate their impact on foundation settlement and bearing capacity. Site development will include building pad preparation, underground utility installation including trench backfill, and concrete foundation construction.

**1.2 Purpose and Scope of Work**

The purpose of this geotechnical study was to investigate the subsurface soil at selected locations within the site for evaluation of physical/engineering properties and liquefaction potential during seismic events. Professional opinions were developed from field and laboratory test data and are provided in this report regarding geotechnical conditions at this site and the effect on design and construction. The scope of our services consisted of the following:

- ▶ Field exploration and in-situ testing of the site soils at selected locations and depths.
- ▶ Laboratory testing for physical and/or chemical properties of selected samples.
- ▶ Review of the available literature and publications pertaining to local geology, faulting, and seismicity.
- ▶ Engineering analysis and evaluation of the data collected.
- ▶ Preparation of this report presenting our findings and professional opinions regarding the geotechnical aspects of project design and construction.

This report addresses the following geotechnical parameters:

- ▶ Subsurface soil and groundwater conditions
- ▶ Site geology, regional faulting and seismicity, near source factors, and site seismic accelerations
- ▶ Liquefaction potential and its mitigation
- ▶ Expansive soil and methods of mitigation
- ▶ Aggressive soil conditions to metals and concrete

Professional opinions with regard to the above parameters are provided for the following:

- ▶ Site grading and earthwork
- ▶ Building pad and foundation subgrade preparation
- ▶ Allowable soil bearing pressures and expected settlements
- ▶ Concrete slabs-on-grade
- ▶ Excavation conditions and buried utility installations
- ▶ Mitigation of the potential effects of salt concentrations in native soil to concrete mixes and steel reinforcement
- ▶ Seismic design parameters

Our scope of work for this report did not include an evaluation of the project site for the presence of environmentally hazardous materials or conditions, storm water infiltration, or landscape suitability of the soil.

### **1.3 Authorization**

Mr. Jimmy Sanders of Sanders, Inc. provided authorization by written agreement to proceed with our work on November 7, 2016. We conducted our work according to our written proposal dated August 26, 2016.

## Section 2

**METHODS OF INVESTIGATION****2.1 Field Exploration**

Subsurface exploration was performed on November 10, 2016 using 2R Drilling of Ontario, California to advance one (1) boring to a depth of 51.5 feet below existing ground surface. The boring was advanced with a truck-mounted, CME 75 drill rig using 8-inch diameter, hollow-stem, continuous-flight augers. The approximate boring location was established in the field and plotted on the site map by sighting to discernible site features. The boring location is shown on the Site and Exploration Plan (Plate A-2).

A professional engineer observed the drilling operations and maintained logs of the soil encountered with sampling depths. Soils were visually classified during drilling according to the Unified Soil Classification System and relatively undisturbed and bulk samples of the subsurface materials were obtained at selected intervals. The relatively undisturbed soil samples were retrieved using a 2-inch outside diameter (OD) split-spoon sampler or a 3-inch OD Modified California Split-Barrel (ring) sampler. In addition, Standard Penetration Tests (SPT) were performed in accordance with ASTM D1586. The samples were obtained by driving the samplers ahead of the auger tip at selected depths using a 140-pound CME automatic hammer with a 30-inch drop. The number of blows required to drive the samplers the last 12 inches of an 18-inch drive depth into the soil is recorded on the boring logs as “blows per foot”. Blow counts (N values) reported on the boring logs represent the field blow counts.

No corrections have been applied to the blow counts shown on the boring logs for effects of overburden pressure, automatic hammer drive energy, drill rod lengths, liners, and sampler diameter. Pocket penetrometer readings were also obtained to evaluate the stiffness of cohesive soils retrieved from sampler barrels.

After logging and sampling the soil, the exploratory boring was backfilled with the excavated material. The backfill was loosely placed and was not compacted to the requirements specified for engineered fill.

The subsurface log is presented on Plate B-1 in Appendix B. A key to the log symbols is presented on Plate B-2. The stratification lines shown on the subsurface log represent the approximate boundaries between the various strata. However, the transition from one stratum to another may be gradual over some range of depth.

## **2.2 Laboratory Testing**

Laboratory tests were conducted on selected bulk (auger cuttings) and relatively undisturbed soil samples obtained from the soil borings to aid in classification and evaluation of selected engineering properties of the site soils. The tests were conducted in general conformance to the procedures of the American Society for Testing and Materials (ASTM) or other standardized methods as referenced below. The laboratory testing program consisted of the following tests:

- ▶ Plasticity Index (ASTM D4318) – used for soil classification and expansive soil design criteria
- ▶ Unconfined Compression (ASTM D2166) – used for soil strength estimates.
- ▶ Chemical Analyses (soluble sulfates & chlorides, pH, and resistivity) (Caltrans Methods) – used for concrete mix proportions and corrosion protection requirements.

The laboratory test results are presented on the subsurface log (Appendix B) and on Plates C-1 and C-2 in Appendix C.

Engineering parameters of soil strength, compressibility and relative density utilized for developing design criteria provided within this report were obtained from the field and laboratory testing program.

## Section 3

**DISCUSSION****3.1 Site Conditions**

The project site is located on the south side of the Imperial County Department of Public Works maintenance yard located at 4736 Hwy 111 in northern Brawley, California. An existing maintenance building occupies the proposed location of the new building.

Adjacent properties are flat-lying and are approximately at the same elevation with this site. Adjacent properties consist of trucking yards to the south and Rubin Seeds, Inc. to the north and east. State Hwy 111 is located to the west.

The project site lies at an elevation of approximately 130 feet below mean sea level (MSL) (El. 870 local datum) in the Imperial Valley region of the California low desert. The surrounding properties lie on terrain which is flat (planar), part of a large agricultural valley, which was previously an ancient lake bed covered with fresh water to an elevation of 43± feet above MSL. Annual rainfall in this arid region is less than 3 inches per year with four months of average summertime temperatures above 100 °F. Winter temperatures are mild, seldom reaching freezing.

**3.2 Geologic Setting**

The project site is located in the Imperial Valley portion of the Salton Trough physiographic province. The Salton Trough is a topographic and geologic structural depression resulting from large scale regional faulting. The trough is bounded on the northeast by the San Andreas Fault and Chocolate Mountains and the southwest by the Peninsular Range and faults of the San Jacinto Fault Zone. The Salton Trough represents the northward extension of the Gulf of California, containing both marine and non-marine sediments deposited since the Miocene Epoch (Morton, 1977). Tectonic activity that formed the trough continues at a high rate as evidenced by deformed young sedimentary deposits and high levels of seismicity. Figure 1 shows the location of the site in relation to regional faults and physiographic features.



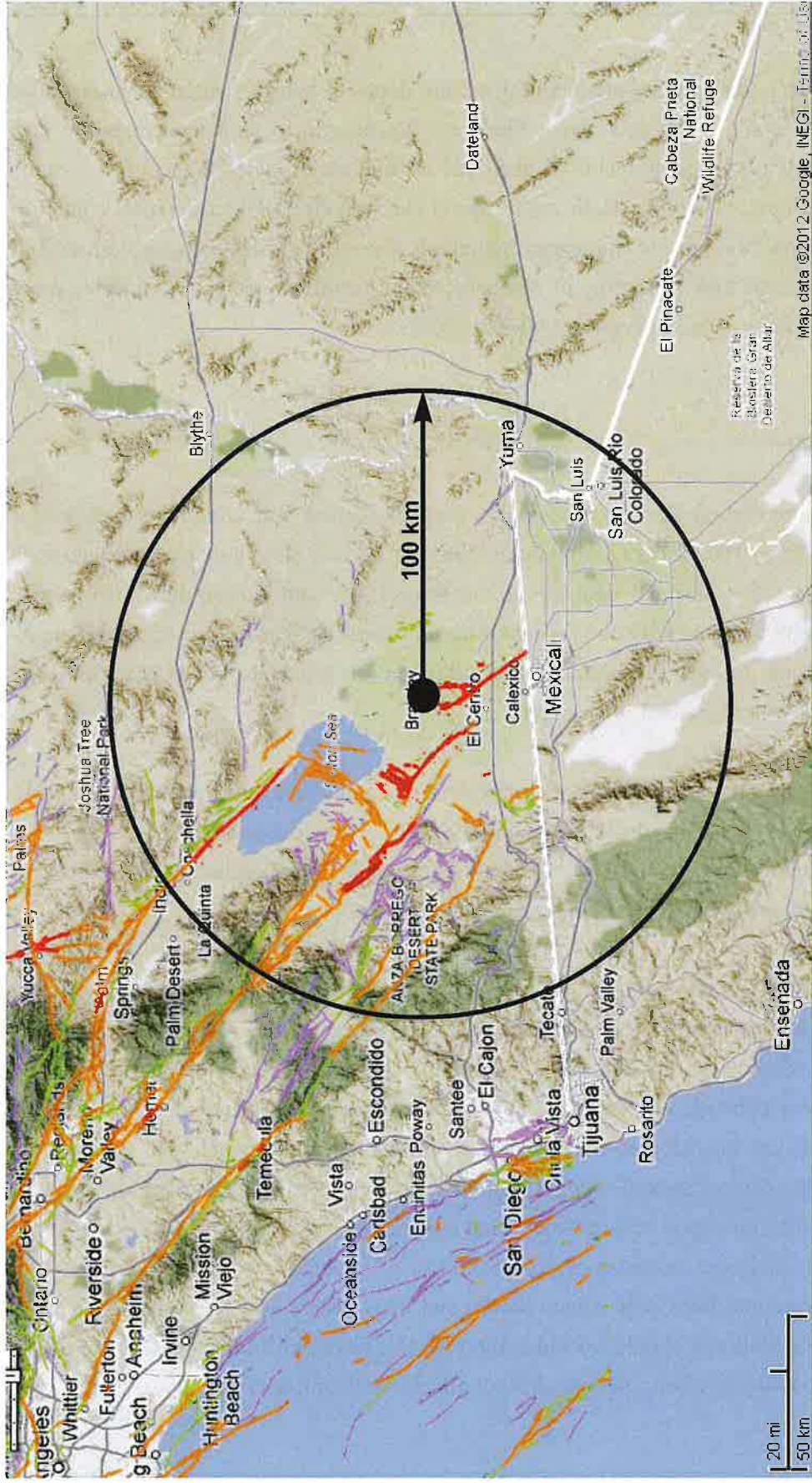

Source: California Geological Survey 2010 Fault Activity Map of California  
<http://www.quake.ca.gov/gmaps/FAM/faultactivitymap.html#>

**LANDMARK**  
 Geo-Engineers and Geologists  
 Project No.: LE16213

Regional Fault Map

Figure 1

The Imperial Valley is directly underlain by lacustrine deposits, which consist of interbedded lenticular and tabular silt, sand, and clay. The Late Pleistocene to Holocene (present) lake deposits are probably less than 100 feet thick and derived from periodic flooding of the Colorado River which intermittently formed a fresh water lake (Lake Cahuilla). Older deposits consist of Miocene to Pleistocene non-marine and marine sediments deposited during intrusions of the Gulf of California. Basement rock consisting of Mesozoic granite and Paleozoic metamorphic rocks are estimated to exist at depths between 15,000 - 20,000 feet.

### 3.3 Subsurface Soil

The U. S. Soil Conservation Service compiled a map of surface soil conditions based on a thirteen-year study from 1962-1975 (Zimmerman, 1981). The Soil Survey maps were published in 1981 and indicate that surficial deposits at the project site and surrounding area consist predominantly of silty clay and silty clay loams of the Imperial-Glenbar soil group (see Plate A-3). These loams are formed in sediment and alluvium of mixed origin (Colorado River overflows and fresh-water lake-bed sediments).

Subsurface soils encountered during the field exploration conducted on November 10, 2016 consist of stiff silty clays to a depth of about 49 feet. A medium dense silty sand was encountered at a depth of 49 to 51.5 feet, the maximum depth of exploration. The subsurface logs (Plate B-1) depict the stratigraphic relationships of the various soil types.

The native surface clays likely exhibit high swell potential (Expansion Index, EI = 110 to 140) when correlated to Plasticity Index tests (ASTM D4318) performed on the native clays. The clay is expansive when wetted and can shrink with moisture loss (drying). Development of building foundations, concrete flatwork, and asphaltic concrete pavements should include provisions for mitigating potential swelling forces and reduction in soil strength, which can occur from saturation of the soil. Causes for soil saturation include landscape irrigation, broken utility lines, or capillary rise in moisture upon sealing the ground surface to evaporation. Moisture losses can occur with lack of landscape watering, close proximity of structures to downslopes and root system moisture extraction from deep rooted shrubs and trees placed near the foundations. The design engineer (foundations) should consider the effects of non-uniform moisture conditions around the entire foundation when selecting design criteria for the foundations.

Typical measures used for similar projects to remediate expansive soil include:

- ▶ Replacement of expansive silts/clays with non-expansive sands or silts.
- ▶ Moisture conditioning subgrade soils to a minimum of 5% above optimum moisture (ASTM D1557) within the drying zone of surface soils.
- ▶ Capping silt/clay soil with a non-expansive sand layer of sufficient thickness (3.0 feet minimum) to reduce the effects of soil shrink/swell.
- ▶ Design of foundations that are resistant to shrink/swell forces of silt/clay soil.
- ▶ A combination of the methods described above

### 3.4 Groundwater

Groundwater was encountered in the boring at about 36 feet during the time of exploration, but may rise with time to approximately 15 to 20 feet below ground surface at this site. There is uncertainty in the accuracy of short-term water level measurements, particularly in fine-grained soil. Groundwater levels may fluctuate with precipitation, irrigation of adjacent properties, site landscape watering, drainage, and site grading.

### 3.5 Faulting

The project site is located in the seismically active Imperial Valley of southern California with numerous mapped faults of the San Andreas Fault System traversing the region. The San Andreas Fault System is comprised of the San Andreas, San Jacinto, and Elsinore Fault Zones in southern California. The Imperial fault represents a transition from the more continuous San Andreas fault to a more nearly echelon pattern characteristic of the faults under the Gulf of California (USGS, 1990). We have performed a computer-aided search of known faults or seismic zones that lie within a 62 mile (100 kilometer) radius of the project site (Table 1).

A fault map illustrating known active faults relative to the site is presented on Figure 1, *Regional Fault Map*. Figure 2 shows the project site in relation to local faults. The criterion for fault classification adopted by the California Geological Survey defines Earthquake Fault Zones along active or potentially active faults. An active fault is one that has ruptured during Holocene time (roughly within the last 11,000 years). A fault that has ruptured during the last 1.8 million years (Quaternary time), but has not been proven by direct evidence to have not moved within Holocene time is considered to be potentially active.

**Table 1**  
**Summary of Characteristics of Closest Known Active Faults**





Fault Name	Approximate Distance (miles)	Approximate Distance (km)	Maximum Moment Magnitude (Mw)	Fault Length (km)	Slip Rate (mm/yr)
Imperial	3.8	6.1	7	62 ± 6	20 ± 5
Brawley *	4.1	6.5			
Superstition Hills	10.3	16.4	6.6	23 ± 2	4 ± 2
Superstition Mountain	12.1	19.3	6.6	24 ± 2	5 ± 3
Rico *	14.5	23.2			
Elmore Ranch	16.8	26.9	6.6	29 ± 3	1 ± 0.5
Unnamed 1*	22.1	35.4			
Unnamed 2*	23.4	37.5			
Painted Gorge Wash*	23.6	37.8			
Yuha*	24.2	38.7			
Yuha Well *	24.2	38.7			
Shell Beds	24.4	39.0			
Vista de Anza*	26.8	42.9			
San Jacinto - Borrego	26.9	43.0	6.6	29 ± 3	4 ± 2
San Andreas - Coachella	27.1	43.4	7.2	96 ± 10	25 ± 5
Hot Springs *	27.1	43.4			
Laguna Salada	28.0	44.8	7	67 ± 7	3.5 ± 1.5
Ocotillo*	30.2	48.4			
Borrego (Mexico)*	31.3	50.1			
Elsinore - Coyote Mountain	32.6	52.2	6.8	39 ± 4	4 ± 2
Cerro Prieto *	34.1	54.6			
Algodones *	35.8	57.3			

\* Note: Faults not included in CGS database.

















ADDITIONAL FAULT SYMBOLS

-  Bar and ball on downthrown side (relative or apparent).
-  Arrows along fault indicate relative or apparent direction of lateral movement.
-  Arrow on fault indicates direction of dip.
-  Low angle fault (barbs on upper plate). Fault surface generally dips less than 45° but locally may have been subsequently steepened. On offshore faults, barbs simply indicate a reverse fault regardless of steepness of dip.

OTHER SYMBOLS

-  Numbers refer to annotations listed in the appendices of the accompanying report. Annotations include fault name, age of fault displacement, and pertinent references including Earthquake Fault Zone maps where a fault has been zoned by the Alquist-Priolo Earthquake Fault Zoning Act. This Act requires the State Geologist to delineate zones to encompass faults with Holocene displacement.
-  Structural discontinuity (offshore) separating differing Neogene structural domains. May indicate discontinuities between basement rocks.
-  Brawley Seismic Zone, a linear zone of seismicity locally up to 10 km wide associated with the releasing step between the Imperial and San Andreas faults.

Geologic Time Scale	Years Before Present (Approx.)	Fault Symbol	Recency of Movement	DESCRIPTION		
				ON LAND	OFFSHORE	
Quaternary	Historic			Displacement during historic time (e.g. San Andreas fault 1906). Includes areas of known fault creep.		
				Displacement during Holocene time.	Fault offsets seafloor sediments or strata of Holocene age.	
	Late Quaternary	11,700			Faults showing evidence of displacement during late Quaternary time.	Fault cuts strata of Late Pleistocene age.
		700,000			Undated Quaternary faults - most faults in this category show evidence of displacement during the last 1,600,000 years; possible exceptions are faults which displace rocks of undifferentiated Plio-Pleistocene age.	Fault cuts strata of Quaternary age.
Pre-Quaternary	1,600,000			Faults without recognized Quaternary displacement or showing evidence of no displacement during Quaternary time. Not necessarily inactive.	Fault cuts strata of Pliocene or older age.	
	4.5 billion (Age of Earth)					

\* Quaternary now recognized as extending to 2.6 Ma (Walker and Geissman, 2009). Quaternary faults in this map were established using the previous 1.6 Ma criterion.

# EXPLANATION

Fault traces on land are indicated by solid lines where well located, by dashed lines where approximately located or inferred, and by dotted lines where concealed by younger rocks or by lakes or bays. Fault traces are queried where continuation or existence is uncertain. Concealed faults in the Great Valley are based on maps of selected subsurface horizons, so locations shown are approximate and may indicate structural trend only. All offshore faults based on seismic reflection profile records are shown as solid lines where well defined, dashed where inferred, queried where uncertain.

## FAULT CLASSIFICATION COLOR CODE (Indicating Recency of Movement)



Fault along which historic (last 200 years) displacement has occurred and is associated with one or more of the following:

(a) a recorded earthquake with surface rupture. (Also included are some well-defined surface breaks caused by ground shaking during earthquakes, e.g. extensive ground breakage, not on the White Wolf fault, caused by the Arvin-Tehachapi earthquake of 1952). The date of the associated earthquake is indicated. Where repeated surface ruptures on the same fault have occurred, only the date of the latest movement may be indicated, especially if earlier reports are not well documented as to location of ground breaks.

(b) fault creep slippage - slow ground displacement usually without accompanying earthquakes.

(c) displaced survey lines.



A triangle to the right or left of the date indicates termination point of observed surface displacement. Solid red triangle indicates known location of rupture termination point. Open black triangle indicates uncertain or estimated location of rupture termination point.



Date bracketed by triangles indicates local fault break.



No triangle by date indicates an intermediate point along fault break.



Fault that exhibits fault creep slippage. Hachures indicate linear extent of fault creep. Annotation (creep with leader) indicates representative locations where fault creep has been observed and recorded.



Square on fault indicates where fault creep slippage has occurred that has been triggered by an earthquake on some other fault. Date of causative earthquake indicated. Squares to right and left of date indicate terminal points between which triggered creep slippage has occurred (creep either continuous or intermittent between these end points).



Holocene fault displacement (during past 11,700 years) without historic record. Geomorphic evidence for Holocene faulting includes sag ponds, scarps showing little erosion, or the following features in Holocene age deposits: offset stream courses, linear scarps, shutter ridges, and triangular faceted spurs. Recency of faulting offshore is based on the interpreted age of the youngest strata displaced by faulting.



Late Quaternary fault displacement (during past 700,000 years). Geomorphic evidence similar to that described for Holocene faults except features are less distinct. Faulting may be younger, but lack of younger overlying deposits precludes more accurate age classification.



Quaternary fault (age undifferentiated). Most faults of this category show evidence of displacement sometime during the past 1.6 million years; possible exceptions are faults which displace rocks of undifferentiated Plio-Pleistocene age. Unnumbered Quaternary faults were based on Fault Map of California, 1975. See Bulletin 201, Appendix D for source data.

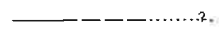

Pre-Quaternary fault (older than 1.6 million years) or fault without recognized Quaternary displacement. Some faults are shown in this category because the source of mapping used was of reconnaissance nature, or was not done with the object of dating fault displacements. Faults in this category are not necessarily inactive.

A fault that has not moved during Quaternary time is considered to be inactive. Review of the current Alquist-Priolo Earthquake Fault Zone maps (CGS, 2016) indicates that the nearest mapped Earthquake Fault Zone is the Imperial fault located approximately 3.8 miles south of the project site.

The project site lies within the Brawley Seismic Zone (BSZ), a pull-apart basin between the southern terminus of the San Andreas fault and the northern trace of the Imperial fault. The BSZ is composed of numerous cross-cutting high angle normal faults. The BSZ extends northward beyond the termination of the mapped Imperial/Brawley faults to beneath the Salton Sea, where it terminates upon intersecting the San Andreas fault near Bombay Beach. The Brawley Seismic Zone was the source of the 1981 5.9Mw Westmorland earthquake sequence that involved activity on at least seven distinct fault planes within the zone. The faults in the Brawley Seismic Zone are considered to be short enough that earthquakes much larger than 6-6.5Mw are unlikely. The California Geological Survey considers the Brawley Seismic Zone to have a maximum magnitude of 6.4Mw, with a very short 24-year average return interval, and a geologic slip rate of 25 mm/year (CDMG, 1996).

### 3.6 General Ground Motion Analysis

The project site is considered likely to be subjected to moderate to strong ground motion from earthquakes in the region. Ground motions are dependent primarily on the earthquake magnitude and distance to the seismogenic (rupture) zone. Acceleration magnitudes also are dependent upon attenuation by rock and soil deposits, direction of rupture and type of fault; therefore, ground motions may vary considerably in the same general area.

CBC General Ground Motion Parameters: The 2013 CBC general ground motion parameters are based on the Risk-Targeted Maximum Considered Earthquake (MCE<sub>R</sub>). The U.S. Geological Survey “U.S. Seismic Design Maps Web Application” (USGS, 2016) was used to obtain the site coefficients and adjusted maximum considered earthquake spectral response acceleration parameters. **The site soils have been classified as Site Class D (stiff soil profile).**



Design spectral response acceleration parameters are defined as the earthquake ground motions that are two-thirds (2/3) of the corresponding  $MCE_R$  ground motions. Design earthquake ground motion parameters are provided in Table 2. **A Risk Category II was determined using Table 1604A.5 and the Seismic Design Category is D since  $S_1$  is less than 0.75g.**

The Maximum Considered Earthquake Geometric Mean ( $MCE_G$ ) peak ground acceleration ( $PGA_M$ ) value was determined from the “U.S. Seismic Design Maps Web Application” (USGS, 2016) for liquefaction and seismic settlement analysis in accordance with 2013 CBC Section 1803A.5.12 and CGS Note 48 ( $PGA_M = F_{PGA} * PGA$ ). **A  $PGA_M$  value of 0.53g has been determined for the project site.**

### 3.7 Seismic and Other Hazards

- ▶ **Groundshaking.** The primary seismic hazard at the project site is the potential for strong groundshaking during earthquakes along the Imperial, Brawley, and Superstition Hills faults.
- ▶ **Surface Rupture.** The California Geological Survey (2016) has established Earthquake Fault Zones in accordance with the 1972 Alquist-Priolo Earthquake Fault Zone Act. The Earthquake Fault Zones consists of boundary zones surrounding well defined, active faults or fault segments. The project site does not lie within an A-P Earthquake Fault Zone; therefore, surface fault rupture is considered to be low at the project site.
- ▶ **Liquefaction.** Liquefaction is unlikely to be a potential hazard at the site due to the lack of saturated granular soil (clay soils predominate). The potential for liquefaction at the site is discussed in more detail in Section 3.8.

#### Other Potential Geologic Hazards.

- ▶ **Landsliding.** The hazard of landsliding is unlikely due to the regional planar topography. No ancient landslides are shown on geologic maps of the region and no indications of landslides were observed during our site investigation.
- ▶ **Volcanic hazards.** The site is not located in proximity to any known volcanically active area and the risk of volcanic hazards is considered very low.
- ▶ **Tsunamis and seiches.** The site is not located near any large bodies of water, so the threat of tsunami, seiches, or other seismically-induced flooding is unlikely.
- ▶ **Flooding.** The project site is located in FEMA Flood Zone X, an area determined to be outside the 0.2% annual chance floodplain (FIRM Panel 06025C1375C).

**Table 2**  
**2013 California Building Code (CBC) and ASCE 7-10 Seismic Parameters**

Soil Site Class:	<b>D</b>	<u>CBC Reference</u>
Latitude:	32.9958 N	Table 20.3-1
Longitude:	-115.5257 W	
Risk Category:	II	
Seismic Design Category:	D	

**Maximum Considered Earthquake (MCE) Ground Motion**

Mapped MCE <sub>R</sub> Short Period Spectral Response	S <sub>s</sub>	1.500 g	Figure 1613.3.1(1)
Mapped MCE <sub>R</sub> 1 second Spectral Response	S <sub>1</sub>	0.600 g	Figure 1613.3.1(2)
Short Period (0.2 s) Site Coefficient	F <sub>a</sub>	1.00	Table 1613.3.3(1)
Long Period (1.0 s) Site Coefficient	F <sub>v</sub>	1.50	Table 1613.3.3(2)
MCE <sub>R</sub> Spectral Response Acceleration Parameter (0.2 s)	S <sub>MS</sub>	1.500 g	= F <sub>a</sub> * S <sub>s</sub> Equation 16-37
MCE <sub>R</sub> Spectral Response Acceleration Parameter (1.0 s)	S <sub>M1</sub>	0.900 g	= F <sub>v</sub> * S <sub>1</sub> Equation 16-38

**Design Earthquake Ground Motion**

Design Spectral Response Acceleration Parameter (0.2 s)	S <sub>DS</sub>	1.000 g	= 2/3*S <sub>MS</sub>	Equation 16-39
Design Spectral Response Acceleration Parameter (1.0 s)	S <sub>D1</sub>	0.600 g	= 2/3*S <sub>M1</sub>	Equation 16-40
	T <sub>L</sub>	8.00 sec		ASCE Figure 22-12
	T <sub>O</sub>	0.12 sec	= 0.2*S <sub>D1</sub> /S <sub>DS</sub>	
	T <sub>S</sub>	0.60 sec	= S <sub>D1</sub> /S <sub>DS</sub>	
Peak Ground Acceleration	PGA <sub>M</sub>	0.53 g		ASCE Equation 11.8-1

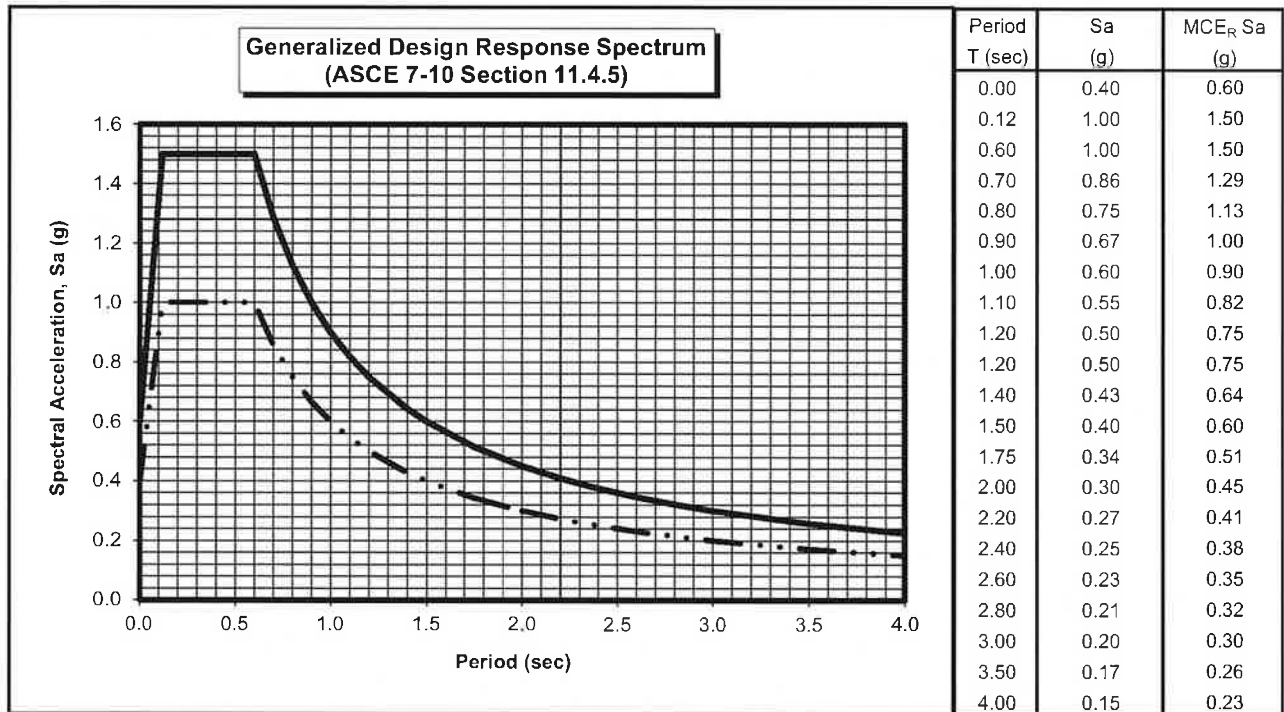

Design Response Spectra  
 MCE<sub>R</sub> Response Spectra

- ▶ **Expansive soil.** In general, much of the near surface soils in the Imperial Valley consist of silty clays and clays which are moderate to highly expansive. The expansive soil conditions are discussed in more detail in Section 3.3.

### 3.8 Liquefaction

Liquefaction occurs when granular soil below the water table is subjected to vibratory motions, such as produced by earthquakes. With strong ground shaking, an increase in pore water pressure develops as the soil tends to reduce in volume. If the increase in pore water pressure is sufficient to reduce the vertical effective stress (suspending the soil particles in water), the soil strength decreases and the soil behaves as a liquid (similar to quicksand). Liquefaction can produce excessive settlement, ground rupture, lateral spreading, or failure of shallow bearing foundations. Four conditions are generally required for liquefaction to occur:

- (1) the soil must be saturated (relatively shallow groundwater);
- (2) the soil must be loosely packed (low to medium relative density);
- (3) the soil must be relatively cohesionless (not clayey); and
- (4) groundshaking of sufficient intensity must occur to function as a trigger mechanism.

All of these conditions exist to some degree at this site.

**Methods of Analysis:** Liquefaction potential at the project site was evaluated using the 1997 NCEER Liquefaction Workshop methods. The 1997 NCEER methods utilize direct SPT blow counts or CPT cone readings from site exploration and earthquake magnitude/PGA estimates from the seismic hazard analysis. The resistance to liquefaction is plotted on a chart of cyclic shear stress ratio (CSR) versus a corrected blow count  $N_{1(60)}$  or  $Q_{c1N}$ . A  $PGA_M$  value of 0.53g was used in the analysis with a 20-foot groundwater depth and a threshold factor of safety (FS) of 1.3. The fine content of liquefiable sands and silts increases the liquefaction resistance in that more ground motion cycles are required to fully develop increased pore pressures. Prior to calculating the settlements, the field SPT blow counts were corrected to account for the type of hammer, borehole diameter, overburden pressure and rod length  $N_{1(60)}$  in accordance with Robertson and Wride (1997). The corrected blow counts were then converted to equivalent clean sand blow counts ( $N_{1(60)cs}$ ).

The soil encountered at the points of exploration included saturated silts and silty sands that could liquefy during a Maximum Considered Earthquake. Liquefaction can occur within a 3-foot thick silty sand layer at a depth of 49 feet below ground surface. The likely triggering mechanism for liquefaction appears to be strong groundshaking associated with the rupture of the Imperial fault.

**Liquefaction Induced Settlements:** *Based on empirical relationships, total induced settlements are estimated to be about ½ inch should liquefaction occur.* The magnitude of potential liquefaction induced differential settlement is estimated at be two-thirds of the total potential settlement in accordance with California Special Publication 117; therefore, there is a potential for ¼ inch of liquefaction induced differential settlement at the project site.

Because of the depth of the liquefiable layer, the 49-foot thick non-liquefiable clay layer may act as a bridge over the liquefiable layer resulting in a fairly uniform ground surface settlement; therefore, wide area subsidence of the soil overburden would be the expected effect of liquefaction rather than bearing capacity failure of the proposed structures.

**Mitigation:** Based on an estimate of ½ inch of liquefaction induced settlements, no mitigation for liquefaction induced settlements is required at this project site.

## Section 4

**DESIGN CRITERIA****4.1 Site Preparation**

**Clearing and Grubbing:** All surface improvements, debris or vegetation including grass, trees, and weeds on the site at the time of construction should be removed from the construction area. Root balls should be completely excavated. Organic strippings should be stockpiled and not used as engineered fill. All trash, construction debris, concrete slabs, old pavement, landfill, and buried obstructions such as old foundations and utility lines exposed during rough grading should be traced to the limits of the foreign material by the grading contractor and removed under our supervision. Any excavations resulting from site clearing should be sloped to a bowl shape to the lowest depth of disturbance and backfilled under the observation of the geotechnical engineer's representative.

**Building Pad Preparation:** The exposed surface soil within the building pad/foundation areas should be removed to 36 inches below the building pad elevation or existing natural surface grade (whichever is lower) extending five feet beyond all exterior wall/column lines (including concreted areas adjacent to the building). Exposed subgrade should be scarified to a depth of 8 inches, uniformly moisture conditioned to 5 to 10% above optimum moisture content and recompacted to 85 to 90% of the maximum density determined in accordance with ASTM D1557 methods.

***The native soil is not suitable for use as engineered fill because of the hydrocarbon odor present in the soil.*** The EPA reports "passive" vapor intrusion mitigation methods may be used to prevent entry of chemical vapors in to buildings. Passive methods include installation of vapor barriers beneath the floor slab, passive venting, and sealing of cracks/openings in the floor slab. It is suggested that, as a minimum, a continuously sealed 30-mil vapor retarder be placed at the bottom of the excavation prior to placement of engineered fill. A second vapor retarder should underlie the concrete slab. Consideration should be made for the complete removal of hydrocarbon affected soils within the occupied building areas.

If foundation designs are to be utilized which do not include provisions for expansive soil, an engineered building support pad consisting of 3.0 feet of granular soil, placed in maximum 8-inch lifts (loose), compacted to a minimum of 90% of ASTM D1557 maximum density at 2% below to 4% above optimum moisture, should be placed below the bottom of the slab. The imported soils should meet the USCS classifications of ML (non-plastic), SM, SP-SM, or SW-SM with a maximum rock size of 3 inches and no less than 5% passing the No. 200 sieve. The geotechnical engineer should approve imported fill soil sources before hauling material to the site. Imported fill should be placed in lifts no greater than 8 inches in loose thickness and compacted to a minimum of 90% of ASTM D1557 maximum dry density at optimum moisture  $\pm 2\%$ .

In areas other than the building pad which are to receive sidewalks or area concrete slabs, the ground surface should be presaturated to a minimum depth of 24 inches and then scarified to 8 inches, moisture conditioned to a minimum of 5% over optimum, and recompacted to 83-87% of ASTM D1557 maximum density just prior to concrete placement.

**Moisture Control and Drainage:** If clay soils are used at building pads (without 3.0 feet of granular, non-plastic soil), the moisture condition of the building pad should be maintained during trenching and utility installation until concrete is placed or should be rewetted by use of multiple applications of water with sprinklers before initiating delayed construction. If soil drying is noted in footings, a 2 to 3 inch depth of water may be used in the bottom of footings to restore footing subgrade moisture and reduce potential edge lift.

Adequate site drainage is essential to future performance of the project. Infiltration of excess irrigation water and stormwaters can adversely affect the performance of the subsurface soil at the site. Positive drainage should be maintained away from all structures (5% for 5 feet minimum across unpaved areas) to prevent ponding and subsequent saturation of the native clay soil. Gutters and downspouts should be used as a means to convey water away from foundations. If landscape irrigation is allowed next to the building, drip irrigation systems or lined planter boxes should be used. The subgrade soil around the entire foundation should be maintained in a moist, but not saturated state, and not allowed to dry out. The developer should consider utilizing drip irrigation systems around the entire building perimeter to maintain soil moisture. Drainage should be maintained without ponding. Trees should be set back from foundations a minimum of 20 feet from the foundation.

**Observation and Density Testing:** All site preparation and fill placement should be continuously observed and tested by a representative of a qualified geotechnical engineering firm. Full-time observation services during the excavation and scarification process is necessary to detect undesirable materials or conditions and soft areas that may be encountered in the construction area. The geotechnical firm that provides observation and testing during construction shall assume the responsibility of "*geotechnical engineer of record*" and, as such, shall perform additional tests and investigation as necessary to satisfy themselves as to the site conditions and the geotechnical parameters for site development.

**Auxiliary Structures Foundation Preparation:** Auxiliary structures such as free standing or retaining walls should have footings extended to a minimum of 30 inches below grade. The existing soil beneath the structure foundation prepared in the manner described for the building pad except the preparation needed only to extend 18 inches below and beyond the footing.

#### **4.2 Utility Trench Backfill**

**Utility Trench Backfill:** Trench backfill for utilities should conform to San Diego Regional Standard Drawing S-4 (Appendix D), using either Type A, B or C backfill.

***Type A*** backfill for HDPE pipe (above groundwater) consists of a 4 to 6 inch bed of ¾-inch crushed rock below the pipe and pipezone backfill (to 12" above top of pipe) consisting of crusher fines (sand). Sewer pipes (SDR-35), water mains, and stormdrain pipes of other than HDPE pipe may use crusher fines for bedding. The crusher fines shall be compacted to a minimum of 95% of ASTM D1557 maximum density. Pipe deflection should be checked to not exceed 2% of pipe diameter. Native clay/silt soils may be used to backfill the remainder of the trench. Soils used for trench backfill shall be compacted to a minimum of 90% of ASTM D1557 maximum density.

***Type B*** backfill for HDPE pipe (shallow cover) requires 6 inches of ¾-inch crushed rock as bedding and to springline of the pipe. Thereafter, sand/cement slurry (3 sack cement factor) should be used to 12 inches above the top of the pipe. Native clay and silt soils may be used in the remainder of the trench backfill as specified above.

*Type C* backfill for HDPE pipe (below or partially below groundwater) shall consist of a geotextile filter fabric encapsulating ¾-inch crushed rock. The crushed rock thickness shall be 6 inches below and to the sides of the pipe and shall extend to 12 inches above the top of the pipe. The filter fabric shall cover the trench bottom, sidewalls and over the top of the crushed rock. Native clay and silt soils may be used in the remainder of the trench backfill as specified above.

**Type C backfill must be used in wet soils and below groundwater for all buried utility pipelines. Dewatering (by well points) is required to at least 24 inches below the trench bottom prior to excavation. Type A backfill may be used in the case of a dewatered trench condition in clay soils only.**

On-site soil free of debris, vegetation, and other deleterious matter may be suitable for use as utility trench backfill above pipezone, but may be difficult to uniformly maintain at specified moistures and compact to the specified densities. Native backfill should only be placed and compacted after encapsulating buried pipes with suitable bedding and pipe envelope material.

Imported granular material is acceptable for backfill of utility trenches. Granular trench backfill used in building pad areas should be plugged with a solid (no clods or voids) 2-foot width of native clay soils at each end of the building foundation to prevent landscape water migration into the trench below the building. Backfill soil of utility trenches within paved areas should be uniformly moisture conditioned to a minimum of 4% above optimum moisture, placed in layers not more than 6 inches in thickness and mechanically compacted to a minimum of 90% of the ASTM D1557 maximum dry density, except that the top 12 inches shall be compacted to 95% (if granular trench backfill).

#### **4.3 Foundations and Settlements**

Shallow spread footings are suitable to support the building provided they are structurally tied with grade-beams to continuous perimeter wall footings to resist differential movement associated with expansive soils. Exterior footings shall be founded a minimum of 24 inches below the surface of the building support pad on a layer of properly prepared and compacted native soil or 18 inches below the surface of the building support pad when supported on a non-expansive granular fill as described in Section 4.1. Interior footings shall have a minimum embedment depth of 12 inches.



The foundations may be designed using an allowable soil bearing pressure of 1,500 psf for compacted clay soil and 2,000 psf when foundations are supported on imported sands (extending a minimum of 1.0 feet below footings). The allowable soil pressure may be increased by 20% for each foot of embedment depth of the footings in excess of 18 inches and by one-third for short term loads induced by winds or seismic events. The maximum allowable soil pressure at increased embedment depths shall not exceed 3,000 psf (clays).

As an alternative to shallow spread foundations, flat plate structural mats or grade-beam reinforced foundations may be used to mitigate expansive soil heave and/or liquefaction related movement.

**Flat Plate Structural Mats:** Flat plate structural mats may be used to mitigate expansive soils at the project site. The structural mat shall have a double mat of steel (minimum No. 4's @ 12 inches O.C. each way – top and bottom) and a minimum thickness of 10 inches. Mat edges shall have a minimum edge footing of 12 inches width and 24 inches depth (below the building pad surface). Mats may be designed by CBC Chapter 18, Section 1808A.6.2 methods (*WRI/CRSI Design of Slab-on-Ground Foundations*).

Structural mats may be designed for a modulus of subgrade reaction (Ks) of 50 pci when placed on compacted clay or a subgrade modulus of 300 pci when placed on 3.0 feet of granular fill. Mats shall overlay 2 inches of sand and a 10-mil polyethylene vapor retarder. The building support pad shall be moisture conditioned and recompacted as specified in Section 4.1 of this report.

**Grade-beam Reinforced Foundations:** Specific soil data for structures with grade-beam reinforced foundations placed on the native clays (without replacement of the surface clays with 3.0 feet of granular fill or lime treated soil placed over native clays) are presented below in accordance with the design method given in CBC Chapter 18 Section 1808A.6.2 (*WRI/CRSI Design of Slab-on-Ground Foundations*):

Weighted Plasticity Index (PI) = 40  
Slope Coefficient (C<sub>s</sub>) = 1.0  
Strength Coefficient (C<sub>o</sub>) = 0.8  
Climatic Rating (C<sub>w</sub>) = 15  
Effective PI = 32  
Maximum Grade-beam Spacing = 17.5 feet

Resistance to horizontal loads will be developed by passive earth pressure on the sides of footings and frictional resistance developed along the bases of footings and concrete slabs. Passive resistance to lateral earth pressure may be calculated using an equivalent fluid pressure of 250 pcf (300 pcf for imported sands) to resist lateral loadings. The top one foot of embedment should not be considered in computing passive resistance unless the adjacent area is confined by a slab or pavement. An allowable friction coefficient of 0.25 (0.35 for imported sands) may also be used at the base of the footings to resist lateral loading.

Foundation movement under the estimated static (non-seismic) loadings and static site conditions are estimated to not exceed 1 inch with differential movement of about two-thirds of total movement for the loading assumptions stated above when the subgrade preparation guidelines given above are followed. Seismically induced liquefaction settlement of the surrounding land mass and structure may be on the order of ½ inch (total) and ¼ inch (differential).

#### **4.4 Slabs-On-Grade**

Structural Concrete: Structural concrete slabs are those slabs (foundations) that underlie structures or patio covers (shades). These slabs that are placed over native clay soil should be designed in accordance with Chapter 18 of the 2013 CBC and shall be a minimum of 6 inches thick due to expansive soil conditions and anticipated wheel loads. Concrete floor slabs shall be monolithically placed with the footings (no cold joints) unless placed on 3.0 feet of granular fill or lime treated soil.

American Concrete Institute (ACI) guidelines (ACI 302.1R-04 Chapter 3, Section 3.2.3) provide recommendations regarding the use of moisture barriers beneath concrete slabs. The concrete floor slabs should be underlain by a 30-mil polyethylene vapor retarder that works as a capillary break to reduce moisture migration into the slab section and migration of hydrocarbon vapors. All laps and seams should be fully sealed as recommended by the manufacturer. The vapor retarder should be protected from puncture. The joints and penetrations should be sealed with the manufacturer's recommended adhesive, pressure-sensitive tape, or both. The vapor retarder should fully line the footing excavations.

Placing sand over the vapor retarder may increase moisture transmission through the slab, because it provides a reservoir for bleed water from the concrete to collect. The sand placed over the vapor retarder may also move and mound prior to concrete placement, resulting in an irregular slab thickness. For areas with moisture sensitive flooring materials, ACI recommends that concrete slabs be placed without a sand cover directly over the vapor retarder, provided that the concrete mix uses a low-water cement ratio and concrete curing methods are employed to compensate for release of bleed water through the top of the slab. The vapor retarder should have a minimum thickness of 30-mil (Stego-Wrap or equivalent).

Structural concrete slab reinforcement should consist of chaired rebar slab reinforcement (minimum of No. 4 bars at 16-inch centers, both horizontal directions) placed at slab mid-height to resist potential swell forces and cracking. Slab thickness and steel reinforcement are minimums only and should be verified by the structural engineer/designer knowing the actual project loadings. All steel components of the foundation system should be protected from corrosion by maintaining a 3-inch minimum concrete cover of densely consolidated concrete at footings (by use of a vibrator). The construction joint between the foundation and any mowstrips/sidewalks placed adjacent to foundations should be sealed with a polyurethane based non-hardening sealant to prevent moisture migration between the joint. Epoxy coated embedded steel components (ASTM D3963/A934) or permanent waterproofing membranes placed at the exterior footing sidewall may also be used to mitigate the corrosion potential of concrete placed in contact with native soil.

Control joints should be provided in all concrete slabs-on-grade at a maximum spacing (in feet) of 2 to 3 times the slab thickness (in inches) as recommended by American Concrete Institute (ACI) guidelines. All joints should form approximately square patterns to reduce randomly oriented contraction cracks. Contraction joints in the slabs should be tooled at the time of the pour or sawcut ( $\frac{1}{4}$  of slab depth) within 6 to 8 hours of concrete placement. Construction (cold) joints in foundations and area flatwork should either be thickened butt-joints with dowels or a thickened keyed-joint designed to resist vertical deflection at the joint. All joints in flatwork should be sealed to prevent moisture, vermin, or foreign material intrusion. Precautions should be taken to prevent curling of slabs in this arid desert region (refer to ACI guidelines).

Non-structural Concrete: All non-structural independent flatwork (sidewalks and uncovered housekeeping slabs) shall be a minimum of 4 inches thick and should be placed on a minimum of 2 inches of concrete sand or aggregate base, dowelled to the perimeter foundations where adjacent to the building to prevent separation and sloped 2% (sidewalks) or 1 to 2% (housekeeping slabs) away from the building. Housekeeping slabs with shade structures shall have a perimeter footing (18-inch embedment depth) and shall have interior grade beams (12-inch minimum embedment depth) at 15 feet on center.

A minimum of 24 inches of moisture conditioned (5% minimum above optimum) and 8 inches of compacted subgrade (85 to 90%) should underlie all independent flatwork. Flatwork which contains steel reinforcing (except wire mesh) should be underlain by a 10-mil (minimum) polyethylene separation sheet and at least a 2-inch sand cover. All flatwork should be jointed in square patterns and at irregularities in shape at a maximum spacing of 8 feet or the least width of the sidewalk.

#### 4.5 Concrete Mixes and Corrosivity

Selected chemical analyses for corrosivity were conducted on bulk samples of the near surface soil from the project site (Plate C-2). The native soils were found to have severe levels of sulfate ion concentration (5,341 ppm). Sulfate ions in high concentrations can attack the cementitious material in concrete, causing weakening of the cement matrix and eventual deterioration by raveling. The following table provides American Concrete Institute (ACI) recommended cement types, water-cement ratio and minimum compressive strengths for concrete in contact with soils:

**Table 4. Concrete Mix Design Criteria due to Soluble Sulfate Exposure**

Sulfate Exposure	Water-soluble Sulfate (SO <sub>4</sub> ) in soil, ppm	Cement Type	Maximum Water-Cement Ratio by weight	Minimum Strength f'c (psi)
Negligible	0-1,000	–	–	–
Moderate	1,000-2,000	II	0.50	4,000
Severe	2,000-20,000	V	0.45	4,500
Very Severe	Over 20,000	V (plus Pozzolon)	0.45	4,500

Note: from ACI 318-11 Table 4.2.1

A minimum of 6.25 sacks per cubic yard of concrete (4,500 psi) of Type V Portland Cement with a maximum water/cement ratio of 0.45 (by weight) should be used for concrete placed in contact with native soil on this project (sitework including streets, sidewalks, driveways, patios, and foundations). Admixtures may be required to allow placement of this low water/cement ratio concrete. Thorough concrete consolidation and hard trowel finishes should be used due to the aggressive soil exposure.

The native soil has very severe levels of chloride ion concentration (2,500 ppm). Chloride ions can cause corrosion of reinforcing steel, anchor bolts and other buried metallic conduits. Resistivity determinations on the soil indicate very severe potential for metal loss because of electrochemical corrosion processes. Mitigation of the corrosion of steel can be achieved by using steel pipes coated with epoxy corrosion inhibitors, asphaltic and epoxy coatings, cathodic protection or by encapsulating the portion of the pipe lying above groundwater with a minimum of 3 inches of densely consolidated concrete. ***No metallic water pipes or conduits should be placed below foundations.***

Foundation designs shall provide a minimum concrete cover of three (3) inches around steel reinforcing or embedded components (anchor bolts, etc.) exposed to native soil or landscape water (to 18 inches above grade). If the 3-inch concrete edge distance cannot be achieved, all embedded steel components (anchor bolts, etc.) shall be epoxy coated for corrosion protection (in accordance with ASTM D3963/A934) or a corrosion inhibitor and a permanent waterproofing membrane shall be placed along the exterior face of the exterior footings. ***Hold-down straps should not be used at foundation edges due to corrosion of metal at its protrusion from the slab edge.*** Additionally, the concrete should be thoroughly vibrated at footings during placement to decrease the permeability of the concrete.

***Copper water piping (except for trap primers) should not be placed under floor slabs.*** All copper piping within 18 inches of ground surface shall be wrapped with two layers of 10 mil plumbers tape or sleeved with PVC piping to prevent contact with soil.

The trap primer pipe shall be completely encapsulated in a PVC sleeve and Type K copper should be utilized if polyethylene tubing cannot be used. Pressurized waterlines are not allowed under the floor slab. Fire protection piping (risers) should be placed outside of the building foundation.

#### **4.6 Excavations**

All site excavations should conform to CalOSHA requirements for Type B soil. The contractor is solely responsible for the safety of workers entering trenches. Temporary excavations with depths of 4 feet or less may be cut nearly vertical for short duration. Excavations deeper than 4 feet will require shoring or slope inclinations in conformance to CAL/OSHA regulations for Type B soil. Surcharge loads of stockpiled soil or construction materials should be set back from the top of the slope a minimum distance equal to the height of the slope. All permanent slopes should not be steeper than 3:1 to reduce wind and rain erosion. Protected slopes with ground cover may be as steep as 2:1. However, maintenance with motorized equipment may not be possible at this inclination.

#### **4.7 Seismic Design**

This site is located in the seismically active southern California area and the site structures are subject to strong ground shaking due to potential fault movements along the Brawley, Superstition Hills, and Imperial Faults. Engineered design and earthquake-resistant construction are the common solutions to increase safety and development of seismic areas. Designs should comply with the latest edition of the CBC for Site Class D using the seismic coefficients given in Section 3.6 and Table 2 of this report.

#### **4.8 Pavements**

Pavements should be designed according to the 2012 Caltrans Highway Design Manual or other acceptable methods. Traffic indices were not provided by the project engineer or owner; therefore, we have provided structural sections for several traffic indices for comparative evaluation.

The public agency or design engineer should decide the appropriate traffic index for the site. Maintenance of proper drainage is necessary to prolong the service life of the pavements. Based on the current Caltrans method, an estimated R-value of 5 for the subgrade soil and assumed traffic indices, the following table provides our estimates for asphaltic concrete (AC) and Portland Cement Concrete (PCC) pavement sections.

**Table 5. Pavement Structural Sections**

R-Value of Subgrade Soil - 5 (estimated)

Design Method - Caltrans 2012

Traffic Index (assumed)	Flexible Pavements		Rigid (PCC) Pavements	
	Asphaltic Concrete Thickness (in.)	Aggregate Base Thickness (in.)	Concrete Thickness (in.)	Aggregate Base Thickness (in.)
4.0	3.0	6.5	5.0	6.0
5.0	3.0	10.0	5.5	6.0
6.0	4.0	11.5	6.0	8.0
6.5	4.0	14.0	7.0	8.0
8.0	5.0	17.5	8.0	11.0

## Notes:

- 1) Asphaltic concrete shall be Caltrans, Type B, ¾ inch maximum (½ inch maximum for parking areas), medium grading with PG70-10 asphalt cement, compacted to a minimum of 95% of the Hveem density (CAL 366).
- 2) Aggregate base shall conform to Caltrans Class 2 (¾ in. maximum), compacted to a minimum of 95% of ASTM D1557 maximum dry density.
- 3) Place pavements on 12 inches of moisture conditioned (minimum 4% above optimum) native clay soil compacted to a minimum of 90% of the maximum dry density determined by ASTM D1557.
- 4) Portland cement concrete for pavements should have Type V cement, a minimum compressive strength of 4,500 psi at 28 days, and a maximum water-cement ratio of 0.45.
- 5) Typical Street Classifications (Imperial County).
 

Parking Areas:	TI = 4.0
Cul-de-Sacs:	TI = 5.0
Local Streets:	TI = 6.0
Minor Collectors:	TI = 6.5
Major Collectors:	TI = 8.0

## Section 5

**LIMITATIONS AND ADDITIONAL SERVICES****5.1 Limitations**

The findings and professional opinions within this report are based on current information regarding the proposed replacement of the existing maintenance building at the Imperial County Public Works Department facility located at 4736 Hwy 111 in northern Brawley, California. The conclusions and professional opinions of this report are invalid if:

- ▶ Structural loads change from those stated or the structures are relocated.
- ▶ The Additional Services section of this report is not followed.
- ▶ This report is used for adjacent or other property.
- ▶ Changes of grade or groundwater occur between the issuance of this report and construction other than those anticipated in this report.
- ▶ Any other change that materially alters the project from that proposed at the time this report was prepared.

Findings and professional opinions in this report are based on selected points of field exploration, geologic literature, laboratory testing, and our understanding of the proposed project. Our analysis of data and professional opinions presented herein are based on the assumption that soil conditions do not vary significantly from those found at specific exploratory locations. Variations in soil conditions can exist between and beyond the exploration points or groundwater elevations may change. If detected, these conditions may require additional studies, consultation, and possible design revisions.

*This report contains information that may be useful in the preparation of contract specifications. However, the report is not worded in such a manner that we recommend its use as a construction specification document without proper modification. The use of information contained in this report for bidding purposes should be done at the contractor's option and risk.*

This report was prepared according to the generally accepted *geotechnical engineering standards of practice* that existed in Imperial County at the time the report was prepared. No express or implied warranties are made in connection with our services.



This report should be considered invalid for periods after two years from the report date without a review of the validity of the findings and professional opinions by our firm, because of potential changes in the Geotechnical Engineering Standards of Practice.

The client has responsibility to see that all parties to the project including, designer, contractor, and subcontractor are made aware of this entire report. The use of information contained in this report for bidding purposes should be done at the contractor's option and risk.

## 5.2 Additional Services

We recommend that a qualified geotechnical consultant be retained to provide the tests and observations services during construction. *The geotechnical engineering firm providing such tests and observations shall become the geotechnical engineer of record and assume responsibility for the project.*

The professional opinions presented in this report are based on the assumption that:

- ▶ Consultation during development of design and construction documents to check that the geotechnical professional opinions are appropriate for the proposed project and that the geotechnical professional opinions are properly interpreted and incorporated into the documents.
- ▶ Landmark Consultants will have the opportunity to review and comment on the plans and specifications for the project prior to the issuance of such for bidding.
- ▶ Observation, inspection, and testing by the geotechnical consultant of record during site clearing, grading, excavation, placement of fills, building pad and subgrade preparation, and backfilling of utility trenches.
- ▶ Observation of foundation excavations and reinforcing steel before concrete placement.
- ▶ Other consultation as necessary during design and construction.

We emphasize our review of the project plans and specifications to check for compatibility with our professional opinions and conclusions. Additional information concerning the scope and cost of these services can be obtained from our office.

# APPENDIX A



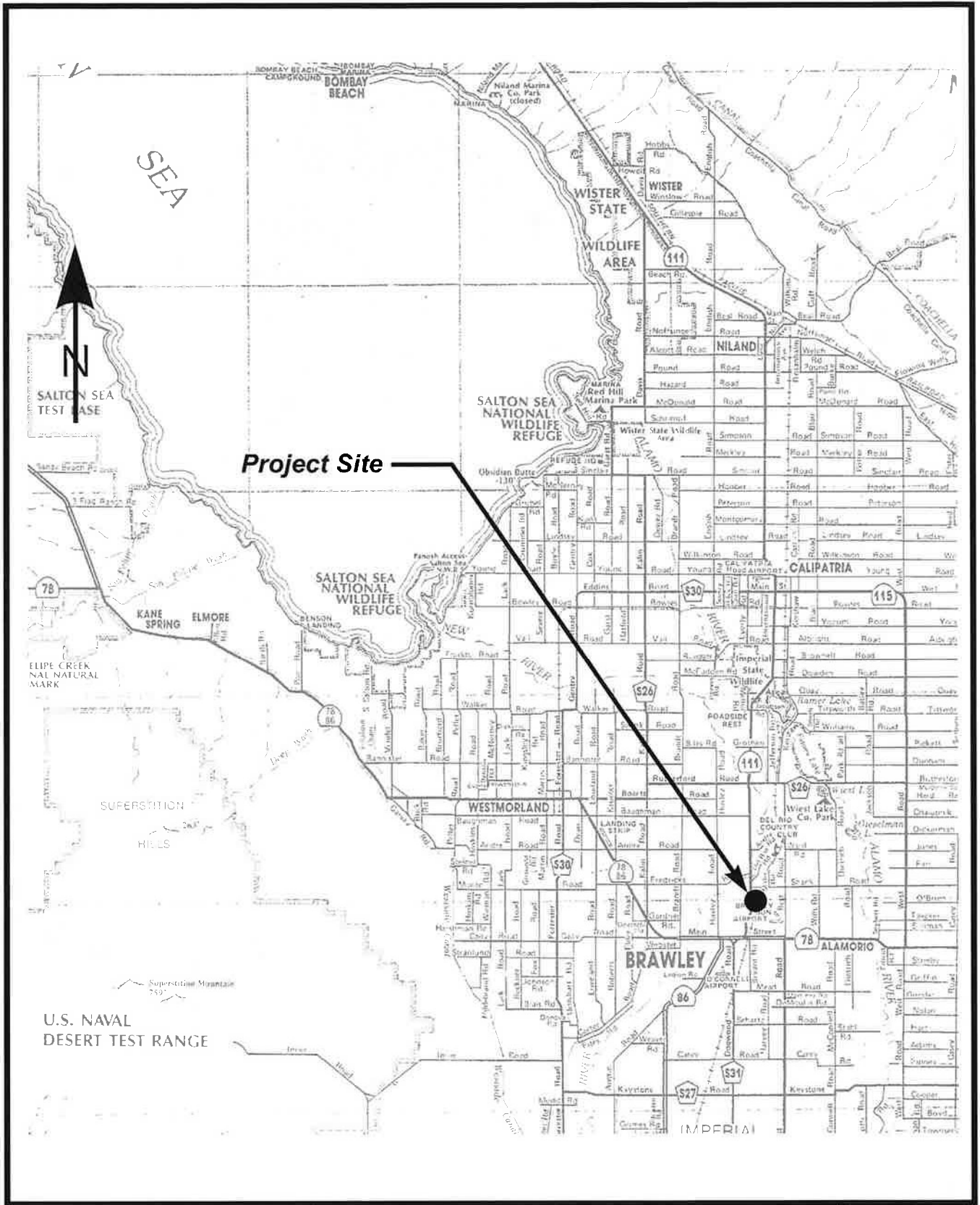

**LANDMARK**  
 Geo-Engineers and Geologists  
 Project No.: LE16213

Vicinity Map

Plate  
 A-1



**LANDMARK**  
Geo-Engineers and Geologists

Project No.: LE16213

Site and Exploration Plan

Plate  
A-2



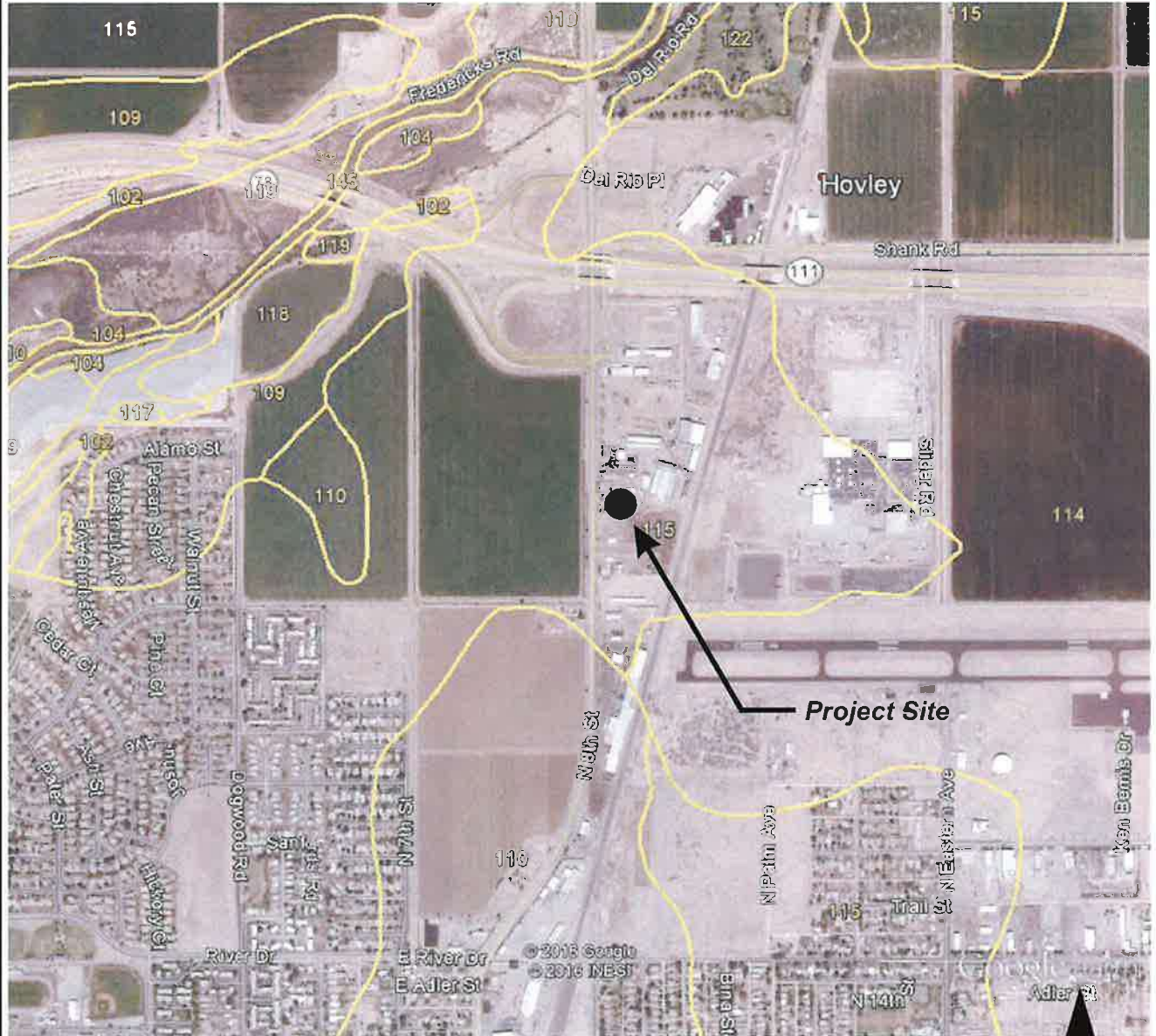

**LANDMARK**

Geo-Engineers and Geologists

Project No.: LE16213

Soil Survey Map

Plate

A-3

Soil Survey of

**IMPERIAL COUNTY  
CALIFORNIA  
IMPERIAL VALLEY AREA**

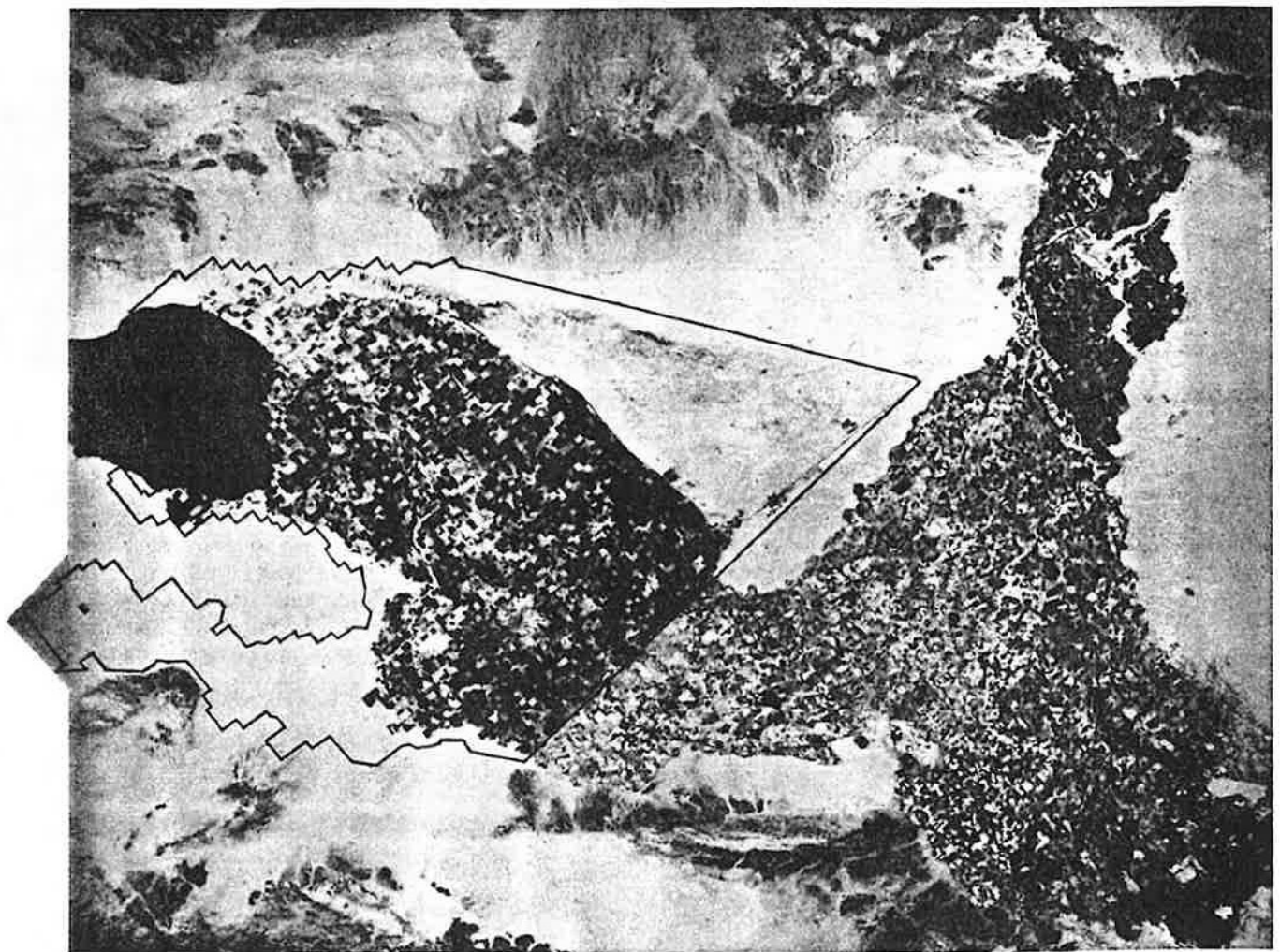

**United States Department of Agriculture Soil Conservation Service**  
in cooperation with  
**University of California Agricultural Experiment Station**  
and  
**Imperial Irrigation District**

TABLE 11.--ENGINEERING INDEX PROPERTIES

[The symbol &gt; means more than. Absence of an entry indicates that data were not estimated]

Soil name and map symbol	Depth	USDA texture	Classification		Frag-ments > 3 inches	Percentage passing sieve number--				Liquid limit	Plas-ticity index
			Unified	AASHTO		4	10	40	200		
	In				Pct					Pct	
100----- Antho	0-13	Loamy fine sand	SM	A-2	0	100	100	75-85	10-30	---	NP
	13-60	Sandy loam, fine sandy loam.	SM	A-2, A-4	0	90-100	75-95	50-60	15-40	---	NP
101*: Antho-----	0-8	Loamy fine sand	SM	A-2	0	100	100	75-85	10-30	---	NP
	8-60	Sandy loam, fine sandy loam.	SM	A-2, A-4	0	90-100	75-95	50-60	15-40	---	NP
Superstition-----	0-6	Fine sand-----	SM	A-2	0	100	95-100	70-85	15-25	---	NP
	6-60	Loamy fine sand, fine sand, sand.	SM	A-2	0	100	95-100	70-85	15-25	---	NP
102*. Badland											
103----- Carsitas	0-10	Gravelly sand---	SP, SP-SM	A-1, A-2	0-5	60-90	50-85	30-55	0-10	---	NP
	10-60	Gravelly sand, gravelly coarse sand, sand.	SP, SP-SM	A-1	0-5	60-90	50-85	25-50	0-10	---	NP
104* Fluvaquents											
105----- Glenbar	0-13	Clay loam-----	CL	A-6	0	100	100	90-100	70-95	35-45	15-30
	13-60	Clay loam, silty clay loam.	CL	A-6	0	100	100	90-100	70-95	35-45	15-30
106----- Glenbar	0-13	Clay loam-----	CL	A-6, A-7	0	100	100	90-100	70-95	35-45	15-25
	13-60	Clay loam, silty clay loam.	CL	A-6, A-7	0	100	100	90-100	70-95	35-45	15-25
107*----- Glenbar	0-13	Loam-----	ML, CL-ML, CL	A-4	0	100	100	100	70-80	20-30	NP-10
	13-60	Clay loam, silty clay loam.	CL	A-6, A-7	0	100	100	95-100	75-95	35-45	15-30
108----- Holtville	0-14	Loam-----	ML	A-4	0	100	100	85-100	55-95	25-35	NP-10
	14-22	Clay, silty clay	CL, CH	A-7	0	100	100	95-100	85-95	40-65	20-35
	22-60	Silt loam, very fine sandy loam.	ML	A-4	0	100	100	95-100	65-85	25-35	NP-10
109----- Holtville	0-17	Silty clay-----	CL, CH	A-7	0	100	100	95-100	85-95	40-65	20-35
	17-24	Clay, silty clay	CL, CH	A-7	0	100	100	95-100	85-95	40-65	20-35
	24-35	Silt loam, very fine sandy loam.	ML	A-4	0	100	100	95-100	65-85	25-35	NP-10
	35-60	Loamy very fine sand, loamy fine sand.	SM, ML	A-2, A-4	0	100	100	75-100	20-55	---	NP
110----- Holtville	0-17	Silty clay-----	CH, CL	A-7	0	100	100	95-100	85-95	40-65	20-35
	17-24	Clay, silty clay	CH, CL	A-7	0	100	100	95-100	85-95	40-65	20-35
	24-35	Silt loam, very fine sandy loam.	ML	A-4	0	100	100	95-100	55-85	25-35	NP-10
	35-60	Loamy very fine sand, loamy fine sand.	SM, ML	A-2, A-4	0	100	100	75-100	20-55	---	NP

See footnote at end of table.

TABLE 11.--ENGINEERING INDEX PROPERTIES--Continued

Soil name and map symbol	Depth In	USDA texture	Classification		Frag- ments > 3 inches Pet	Percentage passing sieve number--				Liquid limit Pet	Plas- ticity index
			Unified	AASHTO		4	10	40	200		
111*: Holtville-----	0-10	Silty clay loam	CL, CH	A-7	0	100	100	95-100	85-95	40-65	20-35
	10-22	Clay, silty clay	CL, CH	A-7	0	100	100	95-100	85-95	40-65	20-35
	22-60	Silt loam, very fine sandy loam.	ML	A-4	0	100	100	95-100	65-85	25-35	NP-10
Imperial-----	0-12	Silty clay loam	CL	A-7	0	100	100	100	85-95	40-50	10-20
	12-60	Silty clay loam, silty clay, clay.	CH	A-7	0	100	100	100	85-95	50-70	25-45
112-----	0-12	Silty clay-----	CH	A-7	0	100	100	100	85-95	50-70	25-45
Imperial	12-60	Silty clay loam, silty clay, clay.	CH	A-7	0	100	100	100	85-95	50-70	25-45
113-----	0-12	Silty clay-----	CH	A-7	0	100	100	100	85-95	50-70	25-45
Imperial	12-60	Silty clay, clay, silty clay loam.	CH	A-7	0	100	100	100	85-95	50-70	25-45
114-----	0-12	Silty clay-----	CH	A-7	0	100	100	100	85-95	50-70	25-45
Imperial	12-60	Silty clay loam, silty clay, clay.	CH	A-7	0	100	100	100	85-95	50-70	25-45
115*: Imperial-----	0-12	Silty clay loam	CL	A-7	0	100	100	100	85-95	40-50	10-20
	12-60	Silty clay loam, silty clay, clay.	CH	A-7	0	100	100	100	85-95	50-70	25-45
Glenbar-----	0-13	Silty clay loam	CL	A-6, A-7	0	100	100	90-100	70-95	35-45	15-25
	13-60	Clay loam, silty clay loam.	CL	A-6, A-7	0	100	100	90-100	70-95	35-45	15-25
116*: Imperial-----	0-13	Silty clay loam	CL	A-7	0	100	100	100	85-95	40-50	10-20
	13-60	Silty clay loam, silty clay, clay.	CH	A-7	0	100	100	100	85-95	50-70	25-45
Glenbar-----	0-13	Silty clay loam	CL	A-6, A-7	0	100	100	90-100	70-95	35-45	15-25
	13-60	Clay loam, silty clay loam.	CL	A-6	0	100	100	90-100	70-95	35-45	15-30
117, 118-----	0-12	Loam-----	ML	A-4	0	95-100	95-100	85-100	75-90	20-30	NP-5
Indio	12-72	Stratified loamy very fine sand to silt loam.	ML	A-4	0	95-100	95-100	85-100	75-90	20-30	NP-5
119*: Indio-----	0-12	Loam-----	ML	A-4	0	95-100	95-100	85-100	75-90	20-30	NP-5
	12-72	Stratified loamy very fine sand to silt loam.	ML	A-4	0	95-100	95-100	85-100	75-90	20-30	NP-5
Vint-----	0-10	Loamy fine sand	SM	A-2	0	95-100	95-100	70-80	25-35	---	NP
	10-60	Loamy sand, loamy fine sand.	SM	A-2	0	95-100	95-100	70-80	20-30	---	NP
120*: Laveen-----	0-12	Loam-----	ML, CL-ML	A-4	0	100	95-100	75-85	55-65	20-30	NP-10
	12-60	Loam, very fine sandy loam.	ML, CL-ML	A-4	0	95-100	85-95	70-80	55-65	15-25	NP-10

See footnote at end of table.



TABLE 11.--ENGINEERING INDEX PROPERTIES--Continued

Soil name and map symbol	Depth	USDA texture	Classification		Frag-ments > 3 inches	Percentage passing - sieve number--				Liquid limit	Plas-ticity index
			Unified	AASHTO		4	10	40	200		
	In				Pct					Pct	
121----- Meloland	0-12	Fine sand-----	SM, SP-SM	A-2, A-3	0	95-100	90-100	75-100	5-30	---	NP
	12-26	Stratified loamy fine sand to silt loam.	ML	A-4	0	100	100	90-100	50-65	25-35	NP-10
	26-71	Clay, silty clay, silty clay loam.	CL, CH	A-7	0	100	100	95-100	85-95	40-65	20-40
122----- Meloland	0-12	Very fine sandy loam.	ML	A-4	0	95-100	95-100	95-100	55-85	25-35	NP-10
	12-26	Stratified loamy fine sand to silt loam.	ML	A-4	0	100	100	90-100	50-70	25-35	NP-10
	26-71	Clay, silty clay, silty clay loam.	CH, CL	A-7	0	100	100	95-100	85-95	40-65	20-40
123*: Meloland-----	0-12	Loam-----	ML	A-4	0	95-100	95-100	95-100	55-85	25-35	NP-10
	12-26	Stratified loamy fine sand to silt loam.	ML	A-4	0	100	100	90-100	50-70	25-35	NP-10
	26-38	Clay, silty clay, silty clay loam.	CH, CL	A-7	0	100	100	95-100	85-95	40-65	20-40
	38-60	Stratified silt loam to loamy fine sand.	SM, ML	A-4	0	100	100	75-100	35-55	25-35	NP-10
Holtville-----	0-12	Loam-----	ML	A-4	0	100	100	65-100	55-95	25-35	NP-10
	12-24	Clay, silty clay	CH, CL	A-7	0	100	100	95-100	85-95	40-65	20-35
	24-36	Silt loam, very fine sandy loam.	ML	A-4	0	100	100	95-100	55-85	25-35	NP-10
	36-60	Loamy very fine sand, loamy fine sand.	SM, ML	A-2, A-4	0	100	100	75-100	20-55	---	NP
124, 125----- Niland	0-23	Gravelly sand---	SM, SP-SM	A-2, A-3	0	90-100	70-95	50-65	5-25	---	NP
	23-60	Silty clay, clay, clay loam.	CL, CH	A-7	0	100	100	85-100	80-95	40-65	20-40
126----- Niland	0-23	Fine sand-----	SM, SP-SM	A-2, A-3	0	90-100	90-100	50-65	5-25	---	NP
	23-60	Silty clay-----	CL, CH	A-7	0	100	100	85-100	80-95	40-65	20-40
127----- Niland	0-23	Loamy fine sand	SM	A-2	0	90-100	90-100	50-65	15-30	---	NP
	23-60	Silty clay-----	CL, CH	A-7	0	100	100	85-100	80-95	40-65	20-40
128*: Niland-----	0-23	Gravelly sand---	SM, SP-SM	A-2, A-3	0	90-100	70-95	50-65	5-25	---	NP
	23-60	Silty clay, clay, clay loam.	CL, CH	A-7	0	100	100	85-100	80-100	40-65	20-40
Imperial-----	0-12	Silty clay-----	CH	A-7	0	100	100	100	85-95	50-70	25-45
	12-60	Silty clay loam, silty clay, clay.	CH	A-7	0	100	100	100	85-95	50-70	25-45
129*: Pits	0-27	Sand-----	SP-SM	A-3, A-1, A-2	0	100	80-100	40-70	5-15	---	NP
130, 131----- Rositas	27-60	Sand, fine sand, loamy sand.	SM, SP-SM	A-3, A-2, A-1	0	100	80-100	40-85	5-30	---	NP

See footnote at end of table.

TABLE 11.--ENGINEERING INDEX PROPERTIES--Continued

Soil name and map symbol	Depth	USDA texture	Classification		Frag-ments > 3 inches	Percentage passing sieve number--				Liquid limit	Plas-ticity index
			Unified	AASHTO		4	10	40	200		
132, 133, 134, 135- Rositas	0-9	Fine sand-----	SM	A-3, A-2	0	100	80-100	50-80	10-25	---	NP
	9-60	Sand, fine sand, loamy sand.	SM, SP-SM	A-3, A-2, A-1	0	100	80-100	40-85	5-30	---	NP
136----- Rositas	0-4	Loamy fine sand	SM	A-1, A-2	0	100	80-100	40-85	10-35	---	NP
	4-60	Sand, fine sand, loamy sand.	SM, SP-SM	A-3, A-2, A-1	0	100	80-100	40-85	5-30	---	NP
137----- Rositas	0-12	Silt loam-----	ML	A-4	0	100	100	90-100	70-90	20-30	NP-5
	12-60	Sand, fine sand, loamy sand.	SM, SP-SM	A-3, A-2, A-1	0	100	80-100	40-85	5-30	---	NP
138*: Rositas-----	0-4	Loamy fine sand	SM	A-1, A-2	0	100	80-100	40-85	10-35	---	NP
	4-60	Sand, fine sand, loamy sand.	SM, SP-SM	A-3, A-2, A-1	0	100	80-100	40-85	5-30	---	NP
Superstition-----	0-6	Loamy fine sand	SM	A-2	0	100	95-100	70-85	15-25	---	NP
	6-60	Loamy fine sand, fine sand, sand.	SM	A-2	0	100	95-100	70-85	15-25	---	NP
139----- Superstition	0-6	Loamy fine sand	SM	A-2	0	100	95-100	70-85	15-25	---	NP
	6-60	Loamy fine sand, fine sand, sand.	SM	A-2	0	100	95-100	70-85	15-25	---	NP
140*: Torriorthents Rock outcrop											
141*: Torriorthents Orthids											
142----- Vint	0-10	Loamy very fine sand.	SM, ML	A-4	0	100	100	85-95	40-65	15-25	NP-5
	10-60	Loamy fine sand	SM	A-2	0	95-100	95-100	70-80	20-30	---	NP
143----- Vint	0-12	Fine sandy loam	ML, CL-ML, SM, SM-SC	A-4	0	100	100	75-85	45-55	15-25	NP-5
	12-60	Loamy sand, loamy fine sand.	SM	A-2	0	95-100	95-100	70-80	20-30	---	NP
144*: Vint-----	0-10	Very fine sandy loam.	SM, ML	A-4	0	100	100	85-95	40-65	15-25	NP-5
	10-40	Loamy fine sand	SM	A-2	0	95-100	95-100	70-80	20-30	---	NP
	40-60	Silty clay-----	CL, CH	A-7	0	100	100	95-100	85-95	40-65	20-35
Indio-----	0-12	Very fine sandy loam.	ML	A-4	0	95-100	95-100	85-100	75-90	20-30	NP-5
	12-40	Stratified loamy very fine sand to silt loam.	ML	A-4	0	95-100	95-100	85-100	75-90	20-30	NP-5
	40-72	Silty clay-----	CL, CH	A-7	0	100	100	95-100	85-95	40-65	20-35

\* See description of the map unit for composition and behavior characteristics of the map unit.

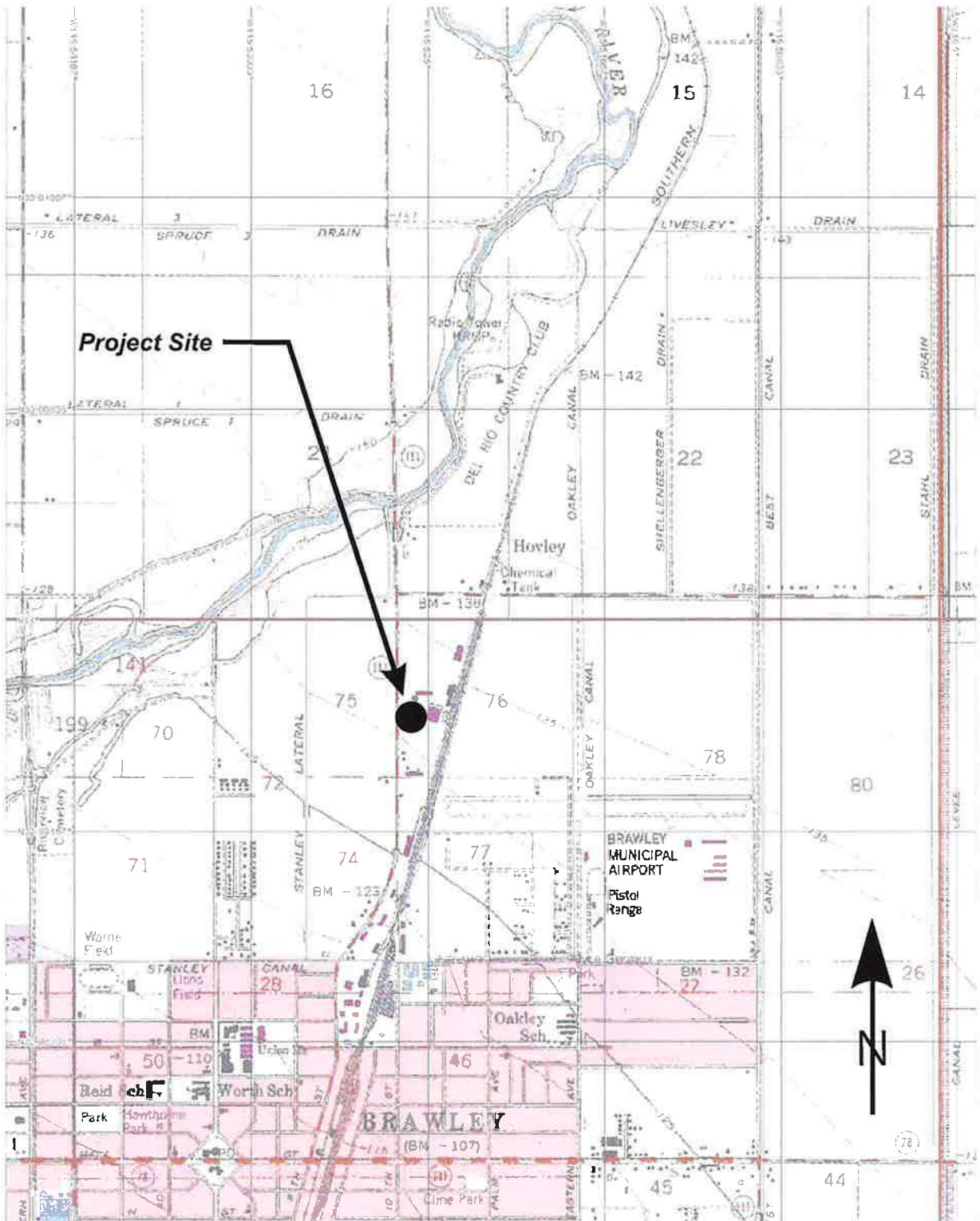

3-D TopoQuad Copyright © 1999 DeLorme Vermont, ME 04066 Source Data: USGS 650 ft Scale: 1 : 22,400 Detail: 13-2 Datum: WGS84

**LANDMARK**  
 Geo-Engineers and Geologists  
 Project No.: LE16213

**Topographic Map**

**Plate  
 A-4**

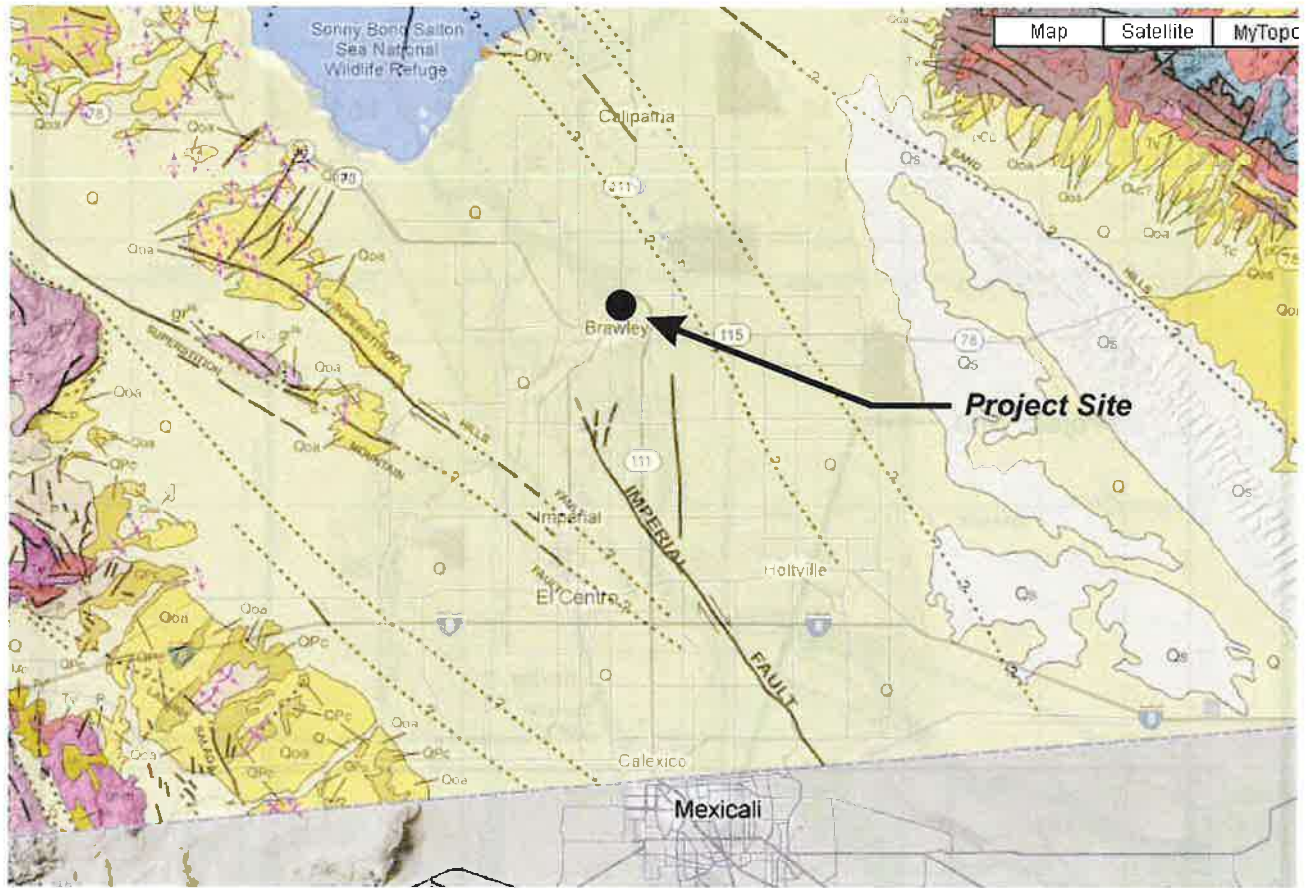

**GEOLOGIC LEGEND**

**Quaternary Deposits**



**Quaternary Volcanic Rocks**

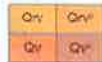

**Tertiary Sedimentary Rocks**



**Tertiary Volcanic Rocks**

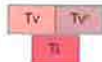

**Tertiary Plutonic Rocks**

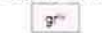

**Mesozoic Sedimentary and Metasedimentary Rocks**

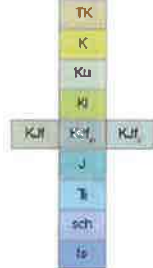

**Mesozoic Mixed Rocks**



**Mesozoic Metavolcanic Rocks**



**Mesozoic Plutonic Rocks**



**Paleozoic Sedimentary and Metasedimentary Rocks**

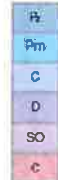

**Paleozoic Mixed Rocks**



**Paleozoic Metavolcanic Rocks**



**Paleozoic Plutonic Rocks**



**Pre-Cambrian Rocks**



**SYMBOLS**

Geologic boundary

Fault traces - solid where well located, dashed where approximately located or inferred, dotted where concealed, and queried where continuation or existence is uncertain. Ball and bar on downthrown side (relative or apparent). Arrows indicate direction of lateral movement (relative or apparent).

Thrust fault (barbs on upper plate)

Regional strike and dip of stratified rocks

Regional strike and dip of stratified rocks (overturned)

Anticlinal fold

Synclinal fold

Monoclinial fold



Site Location  
Lat N32.9958 Long: W-115.5257

**LANDMARK**  
Geo-Engineers and Geologists

Project No.: LE16213

Regional Geologic Map

Plate  
A-5

## **APPENDIX B**



DEPTH	FIELD				LOG OF BORING No. B-1 SHEET 1 OF 1	LABORATORY		
	SAMPLE	USCS CLASS.	BLOW COUNT	POCKET PEN. (tsf)		DESCRIPTION OF MATERIAL	DRY DENSITY (pcf)	MOISTURE CONTENT (% dry wt.)
5			15		2.5 inches of asphaltic  CLAY (CH): Brown and black, moist, stiff, hydrocarbon odors	97.8	24.8	LL=60% PI=40%  c=0.77 tsf
10			27		SILTY CLAY (CL): Brown, moist, stiff, medium plasticity  soft  hard  GW @ 36 ft. at time of drilling			
15		20						
20		13	1.5					
25		8	0.25					
30		20	4.0					
35		14	2.5					
40		12	1.25					
45		8	0.5					
50			13		SILTY SAND (SM): Lt. brown, saturated, medium dense, fine grained			
55					Total Depth = 51.5' Backfilled with excavated soil			
60								

DATE DRILLED: 11/10/16 TOTAL DEPTH: 51.5 Feet DEPTH TO WATER: 36 ft.  
 LOGGED BY: P. LaBrucherie TYPE OF BIT: Hollow Stem Auger DIAMETER: 8 in.  
 SURFACE ELEVATION: Approximately -130' HAMMER WT.: 140 lbs. DROP: 30 in.

PROJECT NO. LE15112



PLATE B-1

## DEFINITION OF TERMS

	PRIMARY DIVISIONS	SYMBOLS	SECONDARY DIVISIONS
Coarse grained soils More than half of material is larger than No. 200 sieve	<b>Gravels</b>	Clean gravels (less than 5% fines)	<b>GW</b> Well graded gravels, gravel-sand mixtures, little or no fines
		More than half of coarse fraction is larger than No. 4 sieve	<b>GP</b> Poorly graded gravels, or gravel-sand mixtures, little or no fines
			Gravel with fines
		<b>GC</b> Clayey gravels, gravel-sand-clay mixtures, plastic fines	
	<b>Sands</b>	Clean sands (less than 5% fines)	<b>SW</b> Well graded sands, gravelly sands, little or no fines
		More than half of coarse fraction is smaller than No. 4 sieve	<b>SP</b> Poorly graded sands or gravelly sands, little or no fines
			Sands with fines
		<b>SC</b> Clayey sands, sand-clay mixtures, plastic fines	
Fine grained soils More than half of material is smaller than No. 200 sieve	<b>Silts and clays</b>		<b>ML</b> Inorganic silts, clayey silts with slight plasticity
	Liquid limit is less than 50%		<b>CL</b> Inorganic clays of low to medium plasticity, gravelly, sandy, or lean clays
			<b>OL</b> Organic silts and organic clays of low plasticity
	<b>Silts and clays</b>		<b>MH</b> Inorganic silts, micaceous or diatomaceous silty soils, elastic silts
	Liquid limit is more than 50%		<b>CH</b> Inorganic clays of high plasticity, fat clays
			<b>OH</b> Organic clays of medium to high plasticity, organic silts
Highly organic soils		<b>PT</b> Peat and other highly organic soils	

### GRAIN SIZES

Silts and Clays	Sand			Gravel		Cobbles	Boulders
	Fine	Medium	Coarse	Fine	Coarse		
	200	40	10	4	3/4"	3"	12"
	US Standard Series Sieve				Clear Square Openings		

Sands, Gravels, etc.	Blows/ft. *
Very Loose	0-4
Loose	4-10
Medium Dense	10-30
Dense	30-50
Very Dense	Over 50

Clays & Plastic Silts	Strength **	Blows/ft. *
Very Soft	0-0.25	0-2
Soft	0.25-0.5	2-4
Firm	0.5-1.0	4-8
Stiff	1.0-2.0	8-16
Very Stiff	2.0-4.0	16-32
Hard	Over 4.0	Over 32

\* Number of blows of 140 lb. hammer falling 30 inches to drive a 2 inch O.D. (1 3/8 in. I.D.) split spoon (ASTM D1586).

\*\* Unconfined compressive strength in tons/s.f. as determined by laboratory testing or approximated by the Standard Penetration Test (ASTM D1586), Pocket Penetrometer, Torvane, or visual observation.

#### Type of Samples:

Ring Sample     
  Standard Penetration Test     
  Shelby Tube     
  Bulk (Bag) Sample

#### Drilling Notes:

1. Sampling and Blow Counts
  - Ring Sampler - Number of blows per foot of a 140 lb. hammer falling 30 inches.
  - Standard Penetration Test - Number of blows per foot.
  - Shelby Tube - Three (3) inch nominal diameter tube hydraulically pushed.
2. P. P. = Pocket Penetrometer (tons/s.f.).
3. NR = No recovery.
4. GWT = Ground Water Table observed @ specified time.

LANDMARK

Geo-Engineers and Geologists

**Project No. LE16213**

Key to Logs

Plate  
B-2

## **APPENDIX C**

---

---



# LANDMARK CONSULTANTS, INC.

**CLIENT:** Sanders, Inc.  
**PROJECT:** ICPW Maintenance Building -- Brawley, CA  
**JOB No.:** LE16213  
**DATE:** 11/17/16

## ATTERBERG LIMITS (ASTM D4318)

Sample Location	Sample Depth (ft)	Liquid Limit (LL)	Plastic Limit (PL)	Plasticity Index (PI)	USCS Classification
B-1	0-5	60	20	40	CH

### PLASTICITY CHART

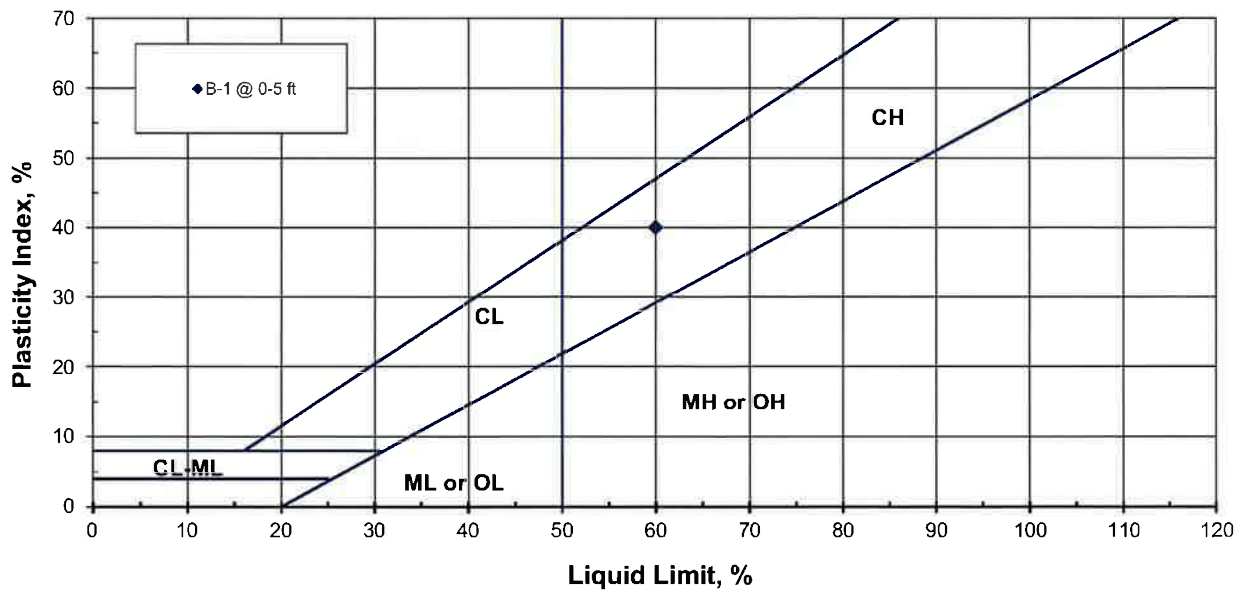

**Project No.:** LE16213

**Atterberg Limits  
Test Results**

**Plate  
C-1**

# LANDMARK CONSULTANTS, INC.

**CLIENT:** Sanders, Inc.

**PROJECT:** ICPW Maintenance Building -- Brawley, CA

**JOB No.:** LE16213

**DATE:** 11/17/16

## CHEMICAL ANALYSIS

<b>Boring:</b>	B-1	
<b>Sample Depth, ft:</b>	0-5	<b>Caltrans Method</b>
<b>pH:</b>	8.0	643
<b>Electrical Conductivity (mmhos):</b>	3.6	424
<b>Resistivity (ohm-cm):</b>	--	643
<b>Chloride (Cl), ppm:</b>	2,500	422
<b>Sulfate (SO<sub>4</sub>), ppm:</b>	5,341	417

### General Guidelines for Soil Corrosivity

Material Affected	Chemical Agent	Range of Values	Degree of Corrosivity
Concrete	Soluble Sulfates (ppm)	0 - 1,000	Low
		1,000 - 2,000	Moderate
		2,000 - 20,000	Severe
		> 20,000	Very Severe
Normal Grade Steel	Soluble Chlorides (ppm)	0 - 200	Low
		200 - 700	Moderate
		700 - 1,500	Severe
		> 1,500	Very Severe
Normal Grade Steel	Resistivity (ohm-cm)	1 - 1,000	Very Severe
		1,000 - 2,000	Severe
		2,000 - 10,000	Moderate
		> 10,000	Low



**Project No.: LE16213**

**Selected Chemical Test Results**

**Plate C-2**

**LANDMARK CONSULTANTS, INC.**

**CLIENT:** Sanders, Inc.  
**PROJECT:** ICPW Maintenance Building -- Brawley, CA  
**JOB NO:** LE16213  
**DATE:** 11/17/2016

**UNCONFINED COMPRESSION TEST (ASTM D2166)**

Boring No.	Sample Depth (ft)	Natural Moisture Content (%)	Unit Dry Weight (pcf)	Maximum Compressive Strength (tsf)	Cohesion (tsf)	Failure Strain (%)
B-1	5	24.8	97.8	1.53	0.77	13.9

**Stress - Strain Plot**

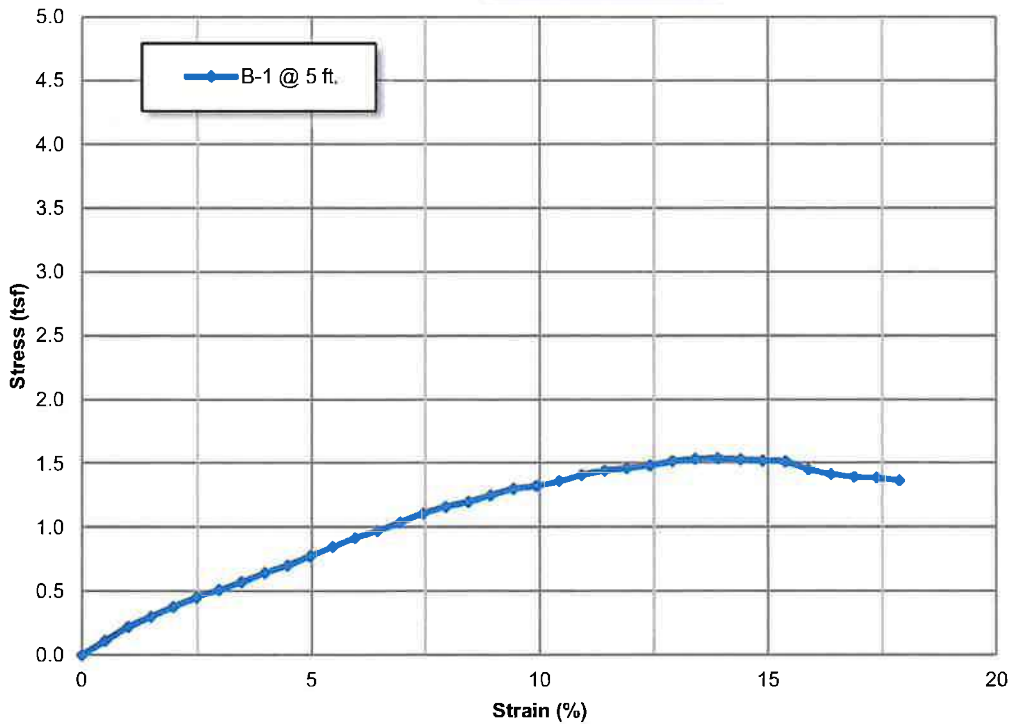

Project No.: LE16213

Unconfined Compression  
Test Results

Plate  
C-3

**APPENDIX D**

---

---

## Liquefaction Evaluation and Settlement Calculation

**Project Name:** ICPW Maintenance Building -- Brawley, CA  
**Project No.:** LE16213  
**Location:** B-1

7  
 Maximum Credible Earthquake  
 Design Ground Motion  
 Total Unit Weight, 0.53 g  
 110 pcf  
 Water Unit Weight, 62.4 pcf  
 Depth to Groundwater, 20 ft  
 Hammer Efficiency, 90  
 Required Factor of Safety, 1.3

Depth (ft)	Blow Counts		Liquefiable Soil (0 / 1)		Overburden Pressure		Sampling Corrections				Corrected SPT (N <sub>1</sub> ) <sub>90</sub>		Fines Content %	SPT Clean Sands (N <sub>1, clean</sub> )	Cyclic Resistance CRR <sub>SPR,5</sub>	Cyclical Stress CSR	Factor of Safety	Volumetric Strain (%)	Induced Subsidence (incht)
	SPT	Mod. Cal.	Soil (0 / 1)	Soil (0 / 1)	Energy C <sub>E</sub>	Borehole C <sub>B</sub>	Rod C <sub>R</sub>	Liner C <sub>L</sub>	Overburden C <sub>u</sub>	SPT (N <sub>1</sub> ) <sub>90</sub>	SPT (N <sub>1</sub> ) <sub>90</sub>								
6	1.83	15	0	0	680	1.0	1.0	0.75	1	1.70	19	95	28	0.345	0.340	Non-Liq.	0.00	0.00	
11	3.35	27	0	0	1210	1.0	1.0	0.80	1	1.32	29	95	39	0.337	0.337	Non-Liq.	0.00	0.00	
16	4.88	20	0	0	1760	1.0	1.0	0.85	1	1.10	28	95	39	0.333	0.333	Non-Liq.	0.00	0.00	
21	6.40	13	0	0	2248	1.0	1.0	0.95	1	0.97	18	95	27	0.311	0.338	1.10	0.00	0.00	
26	7.92	6	0	0	2486	1.0	1.0	0.95	1	0.92	11	95	18	0.190	0.372	0.61	0.00	0.00	
31	9.45	20	0	0	2724	1.0	1.0	0.85	1	0.88	25	95	35	0.395	0.395	Non-Liq.	0.00	0.00	
36	10.97	14	0	0	2962	1.0	1.0	1.00	1	0.85	18	95	26	0.305	0.407	0.90	0.00	0.00	
41	12.50	12	0	0	3200	1.0	1.0	1.00	1	0.81	15	95	23	0.247	0.409	0.72	0.00	0.00	
46	14.02	8	0	0	3438	1.0	1.0	1.00	1	0.78	9	95	16	0.176	0.402	0.52	0.00	0.00	
51	15.54	13	1	1	3676	1.0	1.0	1.00	1	0.76	15	40	23	0.250	0.390	0.76	1.40	0.50	
	0.00																		
	0.00																		
	0.00																		

Based on Proceeding of the NCEER Workshop on Evaluation of Liquefaction Resistance of Soils, Technical Report NCEER-97-0022, December 31, 1997.

Total Settlement 0.50

Corrections to SPT (Modified from Skempton, 1986) as listed by Robertson and Wride.

Factor	Equipment Variable	Term	Correction (p <sub>v</sub> /p <sub>v0</sub> ) <sup>0.5</sup>
Overburden Pressure		C <sub>u</sub>	C <sub>u</sub> ≤ 2
Energy Ratio	Donut Hammer Safety Hammer Automatic-rip Donut type Hammer	C <sub>E</sub>	0.5 to 1.0 0.7 to 1.2 0.8 to 1.3
Borehole Diameter	2.6 inch to 6 inch 6 inch 8 inch	C <sub>B</sub>	1 1.05 1.15
Rod Length	10 feet to 13 feet 13 feet to 19.8 ft. 19.8 ft. to 33 ft. 33 ft. to 98 ft. > 98 ft.	C <sub>R</sub>	0.75 0.85 0.95 1 <1.0
Sampling Method	Standard Sampler Sampler without liners	C <sub>L</sub>	1 1.1 to 1.3

# APPENDIX E

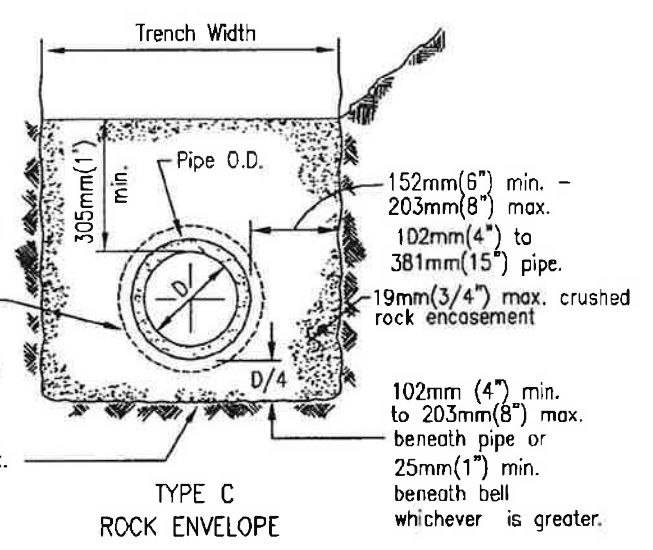
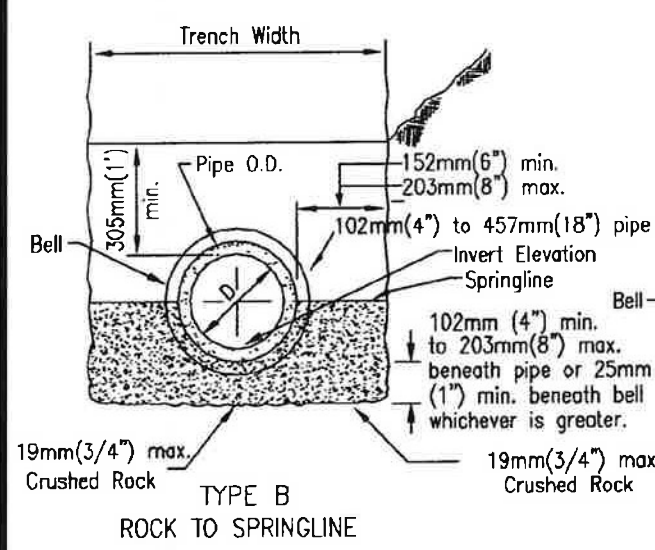
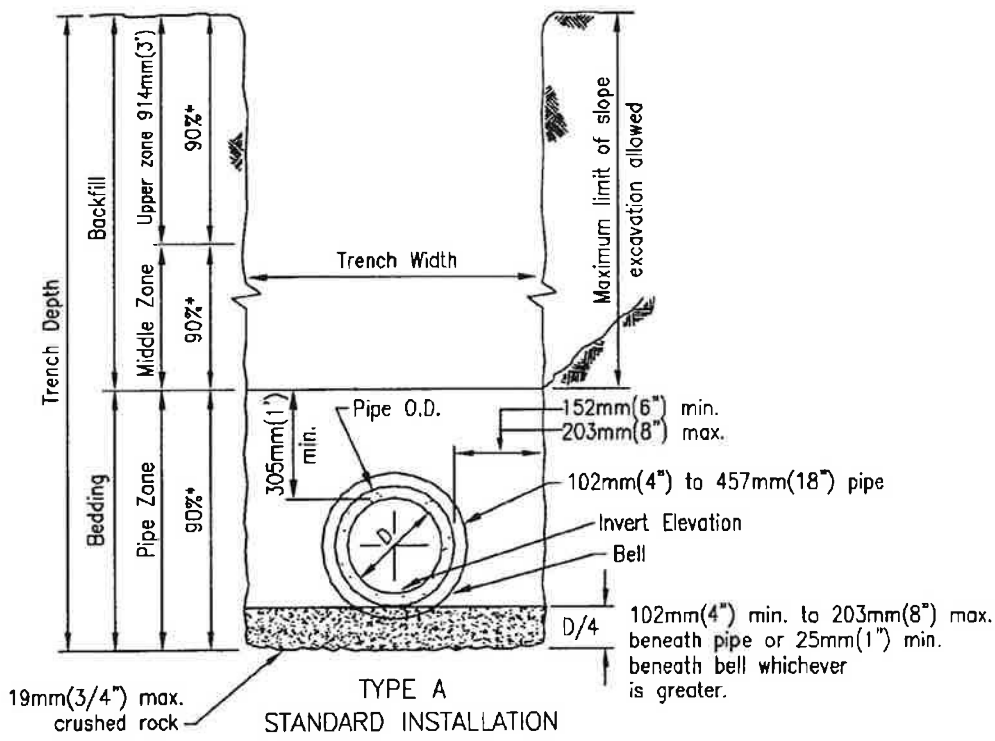

- NOTES**
1. For trenching in improved streets, see Standard Drawings G-24 or G-25 for trench resurfacing.
  2. (\*) indicates minimum relative compaction.
  3. Minimum depth of cover from the top of pipe to finish grade for all sanitary sewer installations shall be 914mm(3')  
For cover less than 914mm(3'), see Standard Drawing S-7 for concrete encasement.
  4. See Type A installation for details not shown for Types B and C.

**APPENDIX F**



## REFERENCES

- American Concrete Institute (ACI), 2013, ACI Manual of Concrete Practice 302.1R-04
- American Society of Civil Engineers (ASCE), 2010, Minimum Design Loads for Buildings and Other Structures: ASCE Standard 7-10.
- California Building Standards Commission, 2013, 2013 California Building Code. California Code of Regulations, Title 24, Part 2, Vol. 2 of 2.
- Caltrans, 2012, Highway Design Manual.
- California Division of Mines and Geology (CDMG), 1996, California Fault Parameters: available at <http://www.consrv.ca.gov/dmg/shezp/fltindex.html>.
- California Geological Survey (CGS), 2016, Fault Activity Map of California <http://www.quake.ca.gov/gmaps/FAM/faultactivitymap.html#>.
- California Geological Survey (CGS), 2016, Alquist-Priolo Earthquake Fault Zone Maps. <http://maps.conservation.ca.gov/cgs/informationwarehouse/index.html?map=regulatorymaps>
- Cetin, K. O., Seed, R. B., Der Kiureghian, A., Tokimatsu, K., Harder, L. F., Jr., Kayen, R. E., and Moss, R. E. S., 2004, Standard penetration test-based probabilistic and deterministic assessment of seismic soil liquefaction potential: ASCE JGGE, Vol., 130, No. 12, p. 1314-1340.
- Geologismiki, 2014, CLiq Computer Program, [www.geologismiki.gr](http://www.geologismiki.gr)
- Ishihara, K. (1985), Stability of natural deposits during earthquakes, Proc. 11<sup>th</sup> Int. Conf. On Soil Mech. And Found. Engrg., Vol. 1, A. A. Balkema, Rotterdam, The Netherlands, 321-376.
- Jones, A. L., 2003, An Analytical Model and Application for Ground Surface Effects from Liquefaction, PhD. Dissertation, University of Washington, 362 p.
- Morton, P. K., 1977, Geology and mineral resources of Imperial County, California: California Division of Mines and Geology, County Report No. 7, 104 p.
- Post-Tensioning Institute (PTI), 2007a, Standard Requirements for Analysis of Shallow Concrete Foundations on Expansive Soils (3<sup>rd</sup> Edition).
- Post-Tensioning Institute (PTI), 2007b, Standard Requirements for Design of Shallow Post-Tensioned Concrete Foundations on Expansive Soils (2<sup>nd</sup> Edition).

- Robertson, P. K., 2014, Seismic liquefaction CPT-based methods: EERI 1<sup>st</sup> Workshop on Geotechnical Earthquake Engineering – Liquefaction Evaluation, Mapping, Simulation and Mitigation. UC San Diego Campus, 10/12/2014.
- Robertson, P. K. and Wride, C. E., 1997, Cyclic Liquefaction and its Evaluation based on the SPT and CPT, Proceeding of the NCEER Workshop on Evaluation of Liquefaction Resistance of Soils, NCEER Technical Report 97-0022, p. 41-88.
- U.S. Geological Survey (USGS), 1990, The San Andreas Fault System, California, Professional Paper 1515.
- U.S. Geological Survey (USGS), 2016, US Seismic Design Maps Web Application, available at <http://geohazards.usgs.gov/designmaps/us/application.php>
- Wire Reinforcement Institute (WRI/CRSI), 2003, Design of Slab-on-Ground Foundations, Tech Facts TF 700-R-03, 23 p.
- Youd, T. L., 2005, Liquefaction-induced flow, lateral spread, and ground oscillation, GSA Abstracts with Programs, Vol. 37, No. 7, p. 252.
- Youd, T. L. and Garris, C. T., 1995, Liquefaction induced ground surface disruption: ASCE Geotechnical Journal, Vol. 121, No. 11.
- Zimmerman, R. P., 1981, Soil survey of Imperial County, California, Imperial Valley Area: U.S. Dept. of Agriculture Soil Conservation Service, 112 p.

**EXHIBIT C**

**APPROVED CONSTRUCTION AND PLAN SPECIFICATIONS**

**IMPERIAL COUNTY BRAWLEY ROAD YARD REPLACEMENT  
4736 STATE HWY-111, BRAWLEY, CA. 92227  
COUNTY PROJECT NO. SR5901ADM**









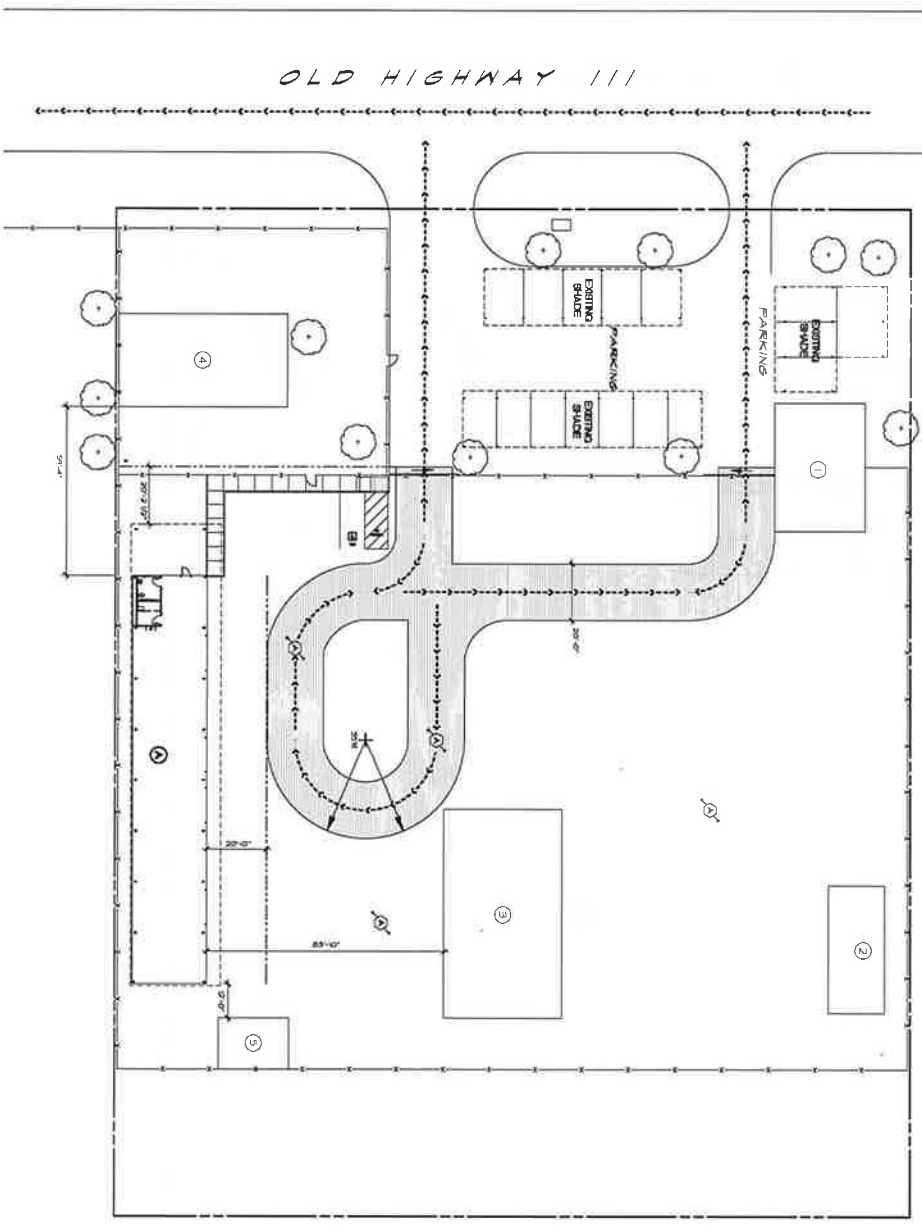

OLD HIGHWAY 111

SCALE: 1" = 30'-0"



**NOTES**  
 1. EXISTING ALL PARKING SPACES TO SUPPORT FIRE TRUCK

**LEGEND**  
 1. EXISTING FIRE RESERVE OR DRIVEWAY  
 2. FIRE TRUCK ACCESS ROUTES (ALL VEHICLES REQUIRED)  
 3. APPROVED PARKING LOT

**BUILDING IDENTIFICATION:**  
 1. EXISTING STRUCTURE TO REMAIN  
 2. EXISTING STRUCTURE TO BE DEMOLISHED  
 3. EXISTING STRUCTURE TO BE REBUILT  
 4. EXISTING STRUCTURE TO BE DEMOLISHED AND REBUILT  
 5. EXISTING STRUCTURE TO BE DEMOLISHED AND REBUILT WITH DIFFERENT USE

**BUILDING DATA:**  
 1. BUILDING  
 2. BUILDING  
 3. BUILDING  
 4. BUILDING  
 5. BUILDING

Project Number  
17-0100

Sheet Number  
**AS2**

Project Title  
**IMPERIAL COUNTY PUBLIC WORKS  
 BRAWLEY MAINTENANCE YARD**

Sheet Title  
**FIRE ACCESS PLAN**

Contract Title  
04-06-1B

Date Last Revised

**Sanders, inc**  
**Architecture/Engineering**  
 1102 INDUSTRY WAY, SUITE A  
 EL CENTRO, CA. 92243  
 760 353 5440 FAX 760 353 5442





OLD HIGHWAY 111

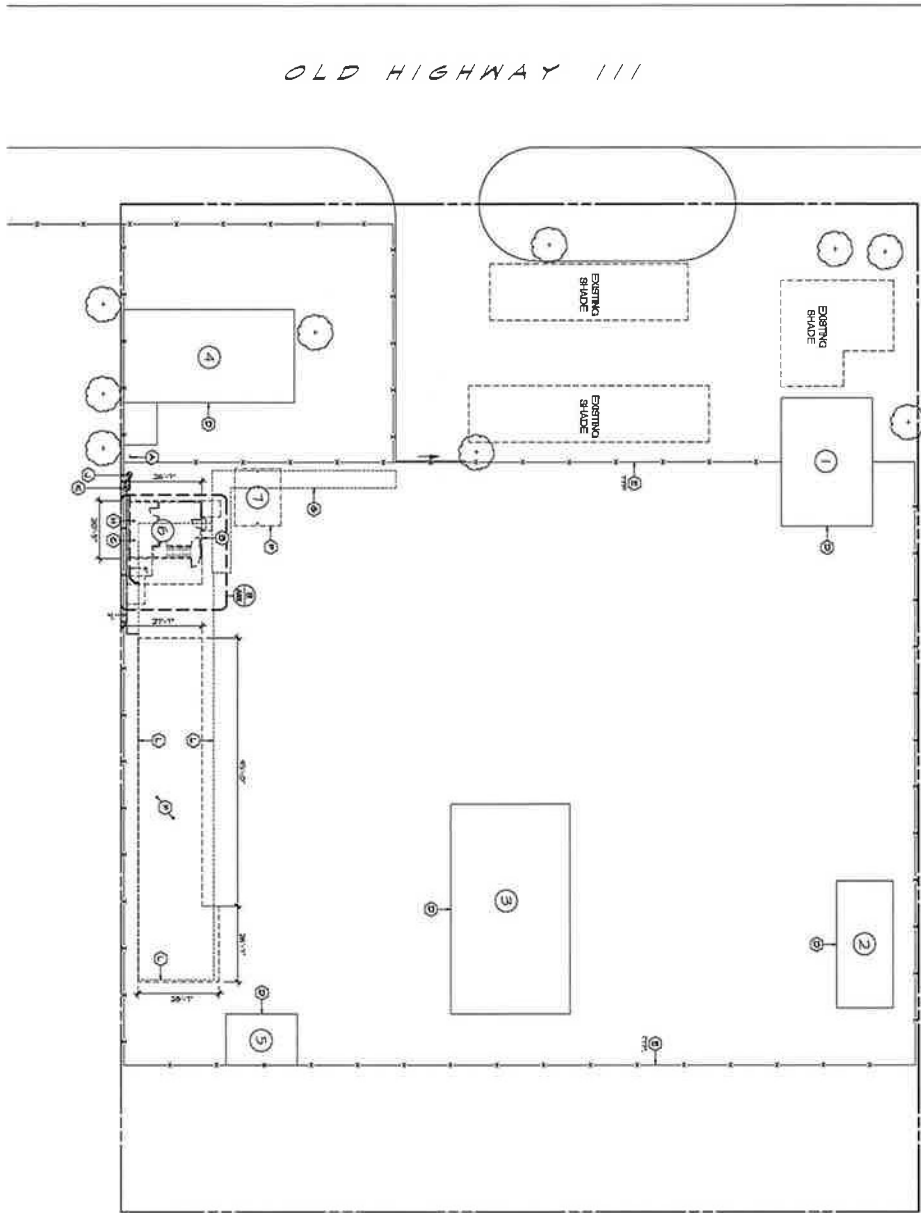

SCALE 1/8" = 1'-0"

ENLARGED FLOOR PLAN DEMO

SCALE 1/8" = 1'-0"

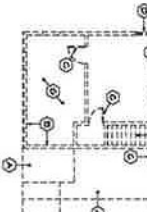

- ENLARGED FLOOR PLAN KENOTES**
- (A) REMOVE EXISTING ROOFING OR CONCRETE SLAB
  - (B) REMOVE EXISTING WOOD SIDING
  - (C) REMOVE EXISTING ROOF AND RAISE
  - (D) REMOVE EXISTING WINDOW
  - (E) REMOVE EXISTING DOOR
  - (F) REMOVE EXISTING WINDOW
  - (G) REMOVE EXISTING WINDOW AND REPAIR WITH WINDUP
  - (H) REMOVE EXISTING WINDOW AND REPAIR WITH WINDUP TO DAMPEN FOR EXISTING FOUNDATION

- BUILDING IDENTIFICATION**
- (1) EXISTING STRUCTURE TO REMAIN
  - (2) EXISTING STRUCTURE TO REMAIN
  - (3) EXISTING STRUCTURE TO REMAIN
  - (4) EXISTING STRUCTURE TO REMAIN
  - (5) EXISTING STRUCTURE TO BE DEMOLISHED
  - (6) EXISTING STRUCTURE TO BE DEMOLISHED
  - (7) EXISTING STRUCTURE TO BE DEMOLISHED
  - (8) EXISTING STRUCTURE TO BE DEMOLISHED
  - (9) EXISTING STRUCTURE TO BE DEMOLISHED

**NOTES**

CONTRACTOR SHALL REMOVE OR REPLACE ANY LINE WORKS OR DAMAGED OR HEAVILY DAMAGED OR SITE SHALL BE RESTORED TO ORIGINAL CONDITION. CONTRACTOR SHALL REMOVE OR REPLACE ANY LINE WORKS OR DAMAGED OR HEAVILY DAMAGED OR SITE SHALL BE RESTORED TO ORIGINAL CONDITION. CONTRACTOR SHALL REMOVE OR REPLACE ANY LINE WORKS OR DAMAGED OR HEAVILY DAMAGED OR SITE SHALL BE RESTORED TO ORIGINAL CONDITION.

- SITE PLAN KENOTES**
- (A) EXISTING POWER POLE TO REMAIN UNCHANGED
  - (B) EXISTING UTILITY TO BE DEMOLISHED
  - (C) EXISTING UTILITY TO BE DEMOLISHED
  - (D) EXISTING UTILITY TO BE DEMOLISHED
  - (E) EXISTING UTILITY TO BE DEMOLISHED
  - (F) EXISTING UTILITY TO BE DEMOLISHED
  - (G) EXISTING UTILITY TO BE DEMOLISHED
  - (H) EXISTING UTILITY TO BE DEMOLISHED
  - (I) EXISTING UTILITY TO BE DEMOLISHED
  - (J) EXISTING UTILITY TO BE DEMOLISHED
  - (K) EXISTING UTILITY TO BE DEMOLISHED
  - (L) EXISTING UTILITY TO BE DEMOLISHED
  - (M) EXISTING UTILITY TO BE DEMOLISHED
  - (N) EXISTING UTILITY TO BE DEMOLISHED
  - (O) EXISTING UTILITY TO BE DEMOLISHED
  - (P) EXISTING UTILITY TO BE DEMOLISHED
  - (Q) EXISTING UTILITY TO BE DEMOLISHED
  - (R) EXISTING UTILITY TO BE DEMOLISHED
  - (S) EXISTING UTILITY TO BE DEMOLISHED
  - (T) EXISTING UTILITY TO BE DEMOLISHED
  - (U) EXISTING UTILITY TO BE DEMOLISHED
  - (V) EXISTING UTILITY TO BE DEMOLISHED
  - (W) EXISTING UTILITY TO BE DEMOLISHED
  - (X) EXISTING UTILITY TO BE DEMOLISHED
  - (Y) EXISTING UTILITY TO BE DEMOLISHED
  - (Z) EXISTING UTILITY TO BE DEMOLISHED

**LEGEND**

--- WITH SHADE LINE SIZE WIDTH  
 --- WITH SHADE LINE SIZE WIDTH

Project Number  
17-0100

Sheet Number  
**AS3**

Project Title  
**IMPERIAL COUNTY PUBLIC WORKS  
BRAWLEY MAINTENANCE YARD**

Sheet Title  
**DEMOLITION SITE PLAN, ENLARGED FLOOR PLAN**

Document Date  
04-06-18

Date Last Revised

**Sanders, Inc.**  
**Architecture/Engineering**  
 102 INDUSTRY WAY, SUITE A  
 EL CENTRO, CA 92243  
 760 353 5440 FAX 760 353 5442



<p><b>STANDARD PARKING SIGN</b></p> <p>SCALE: 1/8" = 1'-0"</p>	<p><b>VAN PARKING SIGN</b></p> <p>SCALE: 1/8" = 1'-0"</p>	<p><b>TOW AWAY SIGN</b></p> <p>SCALE: 1/8" = 1'-0"</p>	<p><b>ACCESSIBLE LOADING ZONE</b></p> <p>SCALE: 1/8" = 1'-0"</p>	<p><b>INTL. SYMBOL OF ACCESSIBILITY</b></p> <p>SCALE: 1/8" = 1'-0"</p>
<p><b>TRUNCATED DOMES</b></p> <p>SCALE: 1/8" = 1'-0"</p> <p><b>6</b></p> <p><b>7</b></p> <p><b>8</b></p>				
<p><b>ACCESSIBLE PARKING DETAIL</b></p> <p>SCALE: 1/8" = 1'-0"</p>				

Project Number  
17-0100

Sheet Number  
**ASX1**

Project Title  
**IMPERIAL COUNTY PUBLIC WORKS  
BRAWLEY YARD BUILDING REPLACEMENT**

Sheet Title  
**ACCESS COMPLIANCE DETAILS**

Drawings Date  
04-06-19

Date Last Revised  
-

**Sanders, inc.**  
Architecture/Engineering

102 INDUSTRY WAY, SUITE A  
EL CENTRO, CA 92243  
760 353 5440 FAX 760 353 5442





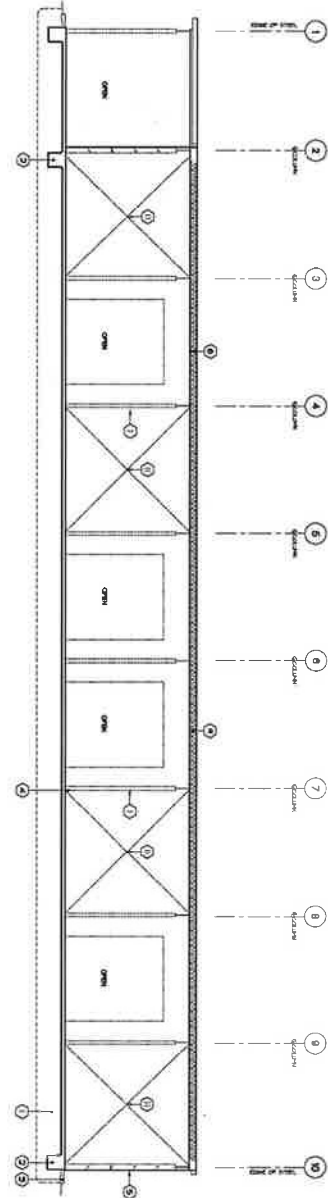

- KEYNOTES**
- 1 BUILDING FOOT - SEE STRUCTURAL AND THE ENGINEERED BUILDING DRAWINGS
  - 2 CONCRETE FOUNDATION - SEE STRUCTURAL DRAWINGS
  - 3 CONCRETE - SEE STRUCTURAL DRAWINGS
  - 4 SITE CONCRETE - SEE ARCHITECTURAL SITE DRAWINGS
  - 5 STEEL ROOF TRUSS - SEE STRUCTURAL DRAWINGS
  - 6 METAL PANEL PRIMER, METAL MANUFACTURER'S DRAWINGS
  - 7 ROOF INSULATION - SEE BUILDING MANUFACTURER'S DRAWINGS
  - 8 ROOF PANELS - SEE BUILDING MANUFACTURER'S DRAWINGS
  - 9 ROOF TRUSS - SEE BUILDING MANUFACTURER'S DRAWINGS
  - 10 ROOF TRUSS - SEE BUILDING MANUFACTURER'S DRAWINGS

SECTION A

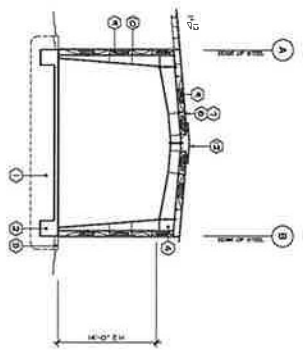

SECTION B



Project Number  
17-0100

Sheet Number  
**A2**

Project Title  
**IMPERIAL COUNTY PUBLIC WORKS  
BRAWLEY YARD BUILDING REPLACEMENT**

Sheet Title  
**ARCHITECTURAL SECTIONS**

Issuance Date  
04-06-15

Date Last Revised

**Sanders, Inc.**  
Architecture/Engineering

102 INDUSTRY WAY, SUITE A  
EL CENTRO, CA 92243  
760 353 5440 FAX 760 353 5442



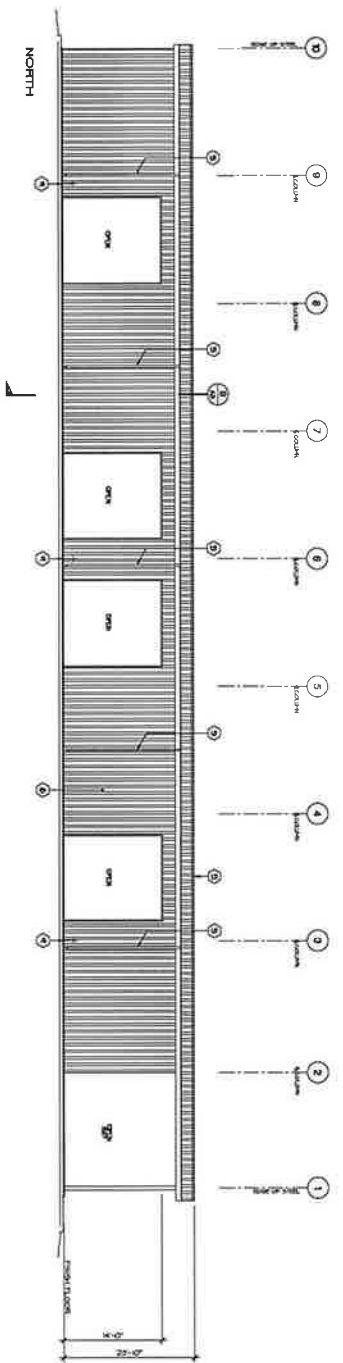
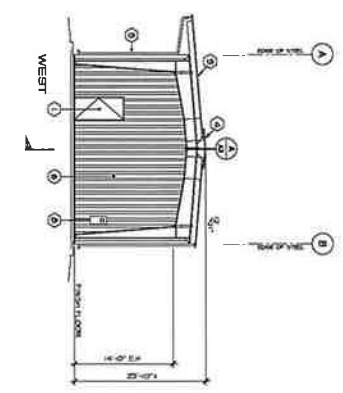
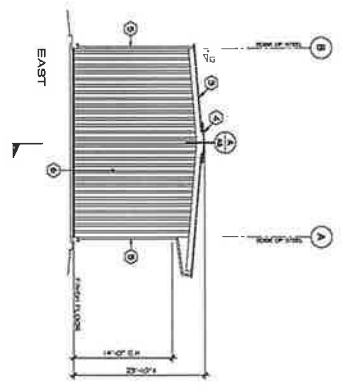
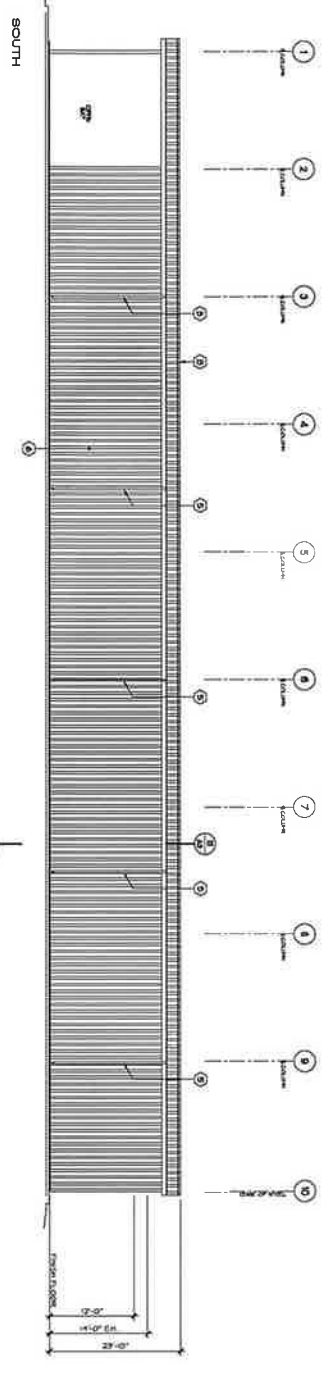

SCALE  
1/8" = 1'-0"  
A

- KEYNOTES**
- 1 COOK / KITCHEN CAB. FLX.
  - 2 SPECIAL ORDER FOR BUILDING MANUFACTURER
  - 3 MODEL UNIT FOR BUILDING MANUFACTURER
  - 4 MODEL UNIT FOR BUILDING MANUFACTURER
  - 5 METAL PANEL OF METAL BUILDING MANUFACTURER
  - 6 METAL PANEL OF METAL BUILDING MANUFACTURER
  - 7 METAL PANEL OF METAL BUILDING MANUFACTURER
  - 8 METAL PANEL OF METAL BUILDING MANUFACTURER
  - 9 METAL PANEL OF METAL BUILDING MANUFACTURER
  - 10 METAL PANEL OF METAL BUILDING MANUFACTURER

Sheet Number  
17-0100  
Sheet Number  
**A3**

Project Title  
**IMPERIAL COUNTY PUBLIC WORKS  
BRAWLEY YARD BUILDING REPLACEMENT**  
Sheet Title  
**EXTERIOR ELEVATIONS**

Drawn Date  
04-06-18  
Date Last Revised

**Sanders, Inc.**  
Architecture/Engineering  
1502 INDUSTRY WAY, SUITE A  
EL CENTRO, CA 92243  
780 353 5440 FAX 780 353 5442



SIGNAGE PLAN

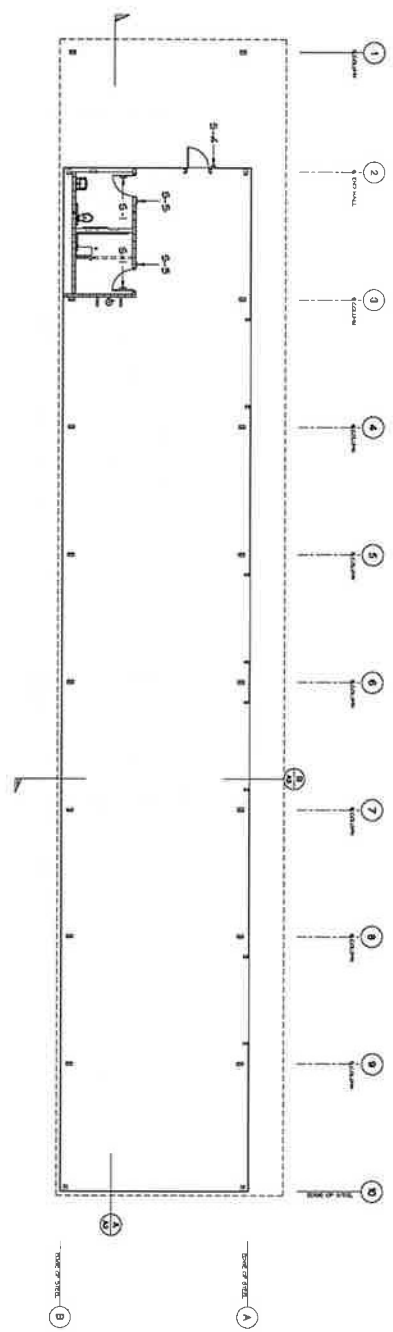

FLOORING PLAN

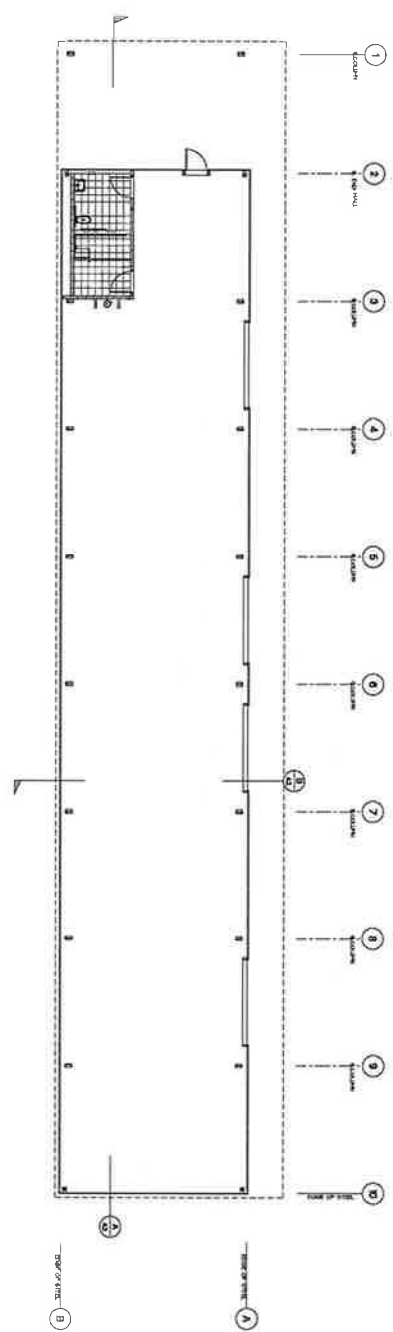

17-0100  
A4



17-0100  
A



NOTES

1. FROM SIGN NOTES SEE (A4)
2. ALL NEW MATERIALS SHALL BE IN ACCORDANCE WITH THE LATEST EDITIONS OF THE BUILDING CODES.
3. EXISTING MATERIALS SHALL BE REPAIRED OR REPLACED AS NECESSARY TO MEET THE LATEST EDITIONS OF THE BUILDING CODES.
4. ALL WORK SHALL BE IN ACCORDANCE WITH THE LATEST EDITIONS OF THE BUILDING CODES.

KEYNOTES

- ① TRANSITION FROM CONCRETE TO VCT OR TILE

LEGEND

- ◻ CERAMIC TILE
- ◻ CONCRETE - FINISH TO MATCH

Project Number  
17-0100

Sheet Number  
**A4**

Project Title  
**IMPERIAL COUNTY PUBLIC WORKS  
BRAWLEY YARD BUILDING REPLACEMENT**

Sheet Title  
**FLOORING PLAN AND SIGNAGE PLAN**

Drawn Date  
04-06-18

Date Last Revised

**Sanders, Inc.**  
Architecture/Engineering

102 INDUSTRY WAY, SUITE A  
EL CENTRO, CA 92243  
760 353 5440 FAX 760 353 5442



ROOF PLAN

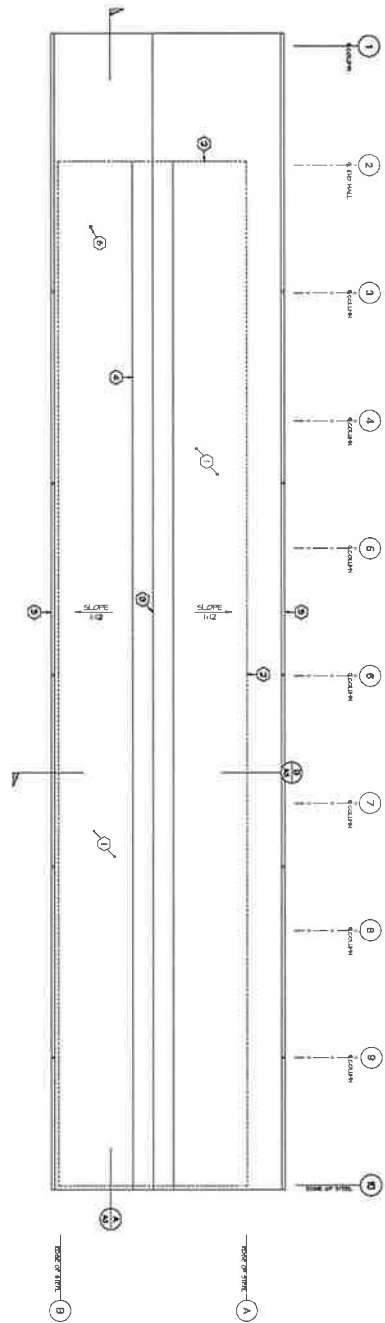

**KEYNOTES**

- 1 FROD 1/2" (ALL SLOPE)
- 2 FIBER GLASS INSULATION (FALL ROOF)
- 3 2" POLYURETHANE INSULATION (FALL ROOF)
- 4 ROOF JOINT
- 5 1" POLYURETHANE INSULATION (FALL ROOF)
- 6 2" POLYURETHANE INSULATION (FALL ROOF)
- 7 2" POLYURETHANE INSULATION (FALL ROOF)
- 8 2" POLYURETHANE INSULATION (FALL ROOF)
- 9 2" POLYURETHANE INSULATION (FALL ROOF)
- 10 2" POLYURETHANE INSULATION (FALL ROOF)

**NOTES**

- 1. ALL ROOF JOINTS SHALL BE PROTECTED BY A 2" POLYURETHANE INSULATION (FALL ROOF)
- 2. ALL ROOF JOINTS SHALL BE PROTECTED BY A 2" POLYURETHANE INSULATION (FALL ROOF)
- 3. ALL ROOF JOINTS SHALL BE PROTECTED BY A 2" POLYURETHANE INSULATION (FALL ROOF)

SCALE: 1/8" = 1'-0"



Project Number  
17-0100

Sheet Number  
**A5**

Project Title  
**IMPERIAL COUNTY PUBLIC WORKS  
BRAWLEY YARD BUILDING REPLACEMENT**

Sheet Title  
**ROOF PLAN**

Drawn Date  
04-06-13

Date Last Revised

**Sanders, INC.**  
Architecture/Engineering

102 INDUSTRY WAY, SUITE A  
EL CENTRO, CA 92243  
760 353 5440 FAX 760 353 5442







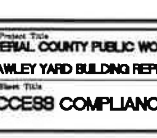
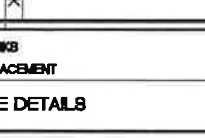
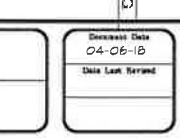
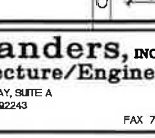
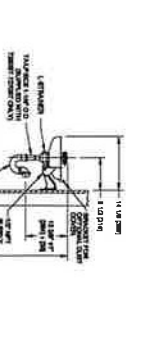
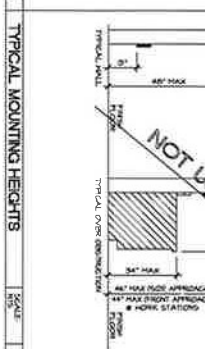
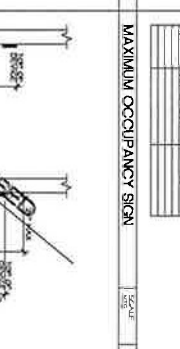
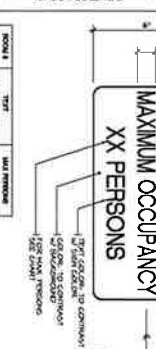
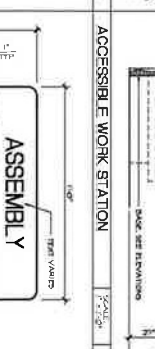
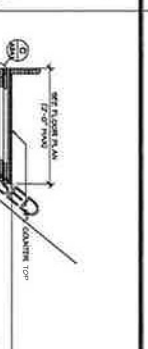
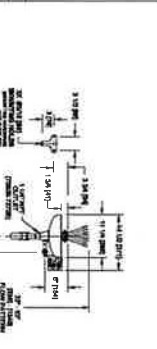
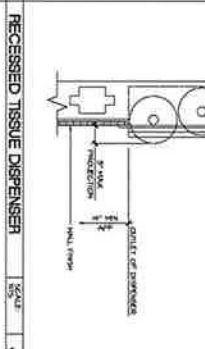
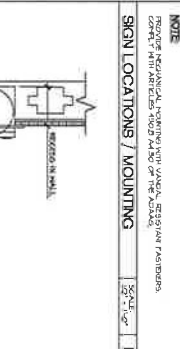
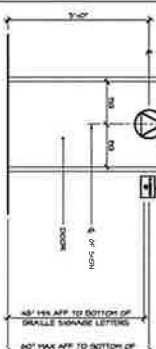
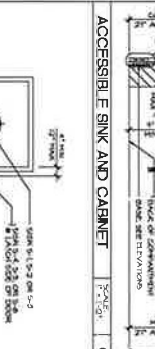
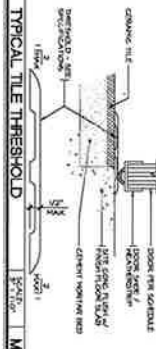
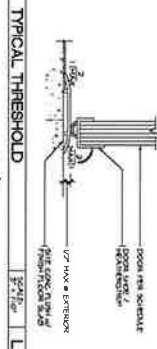
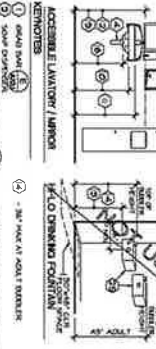
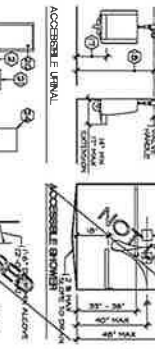
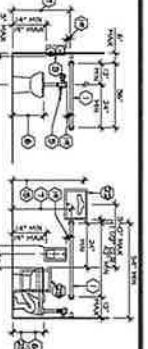
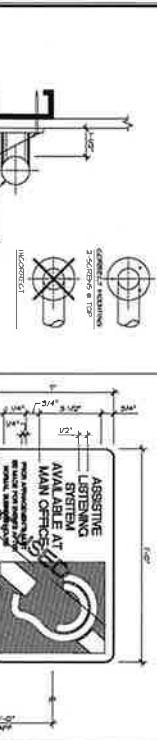
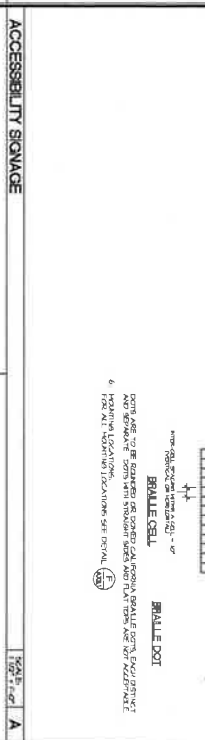
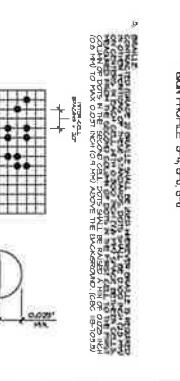
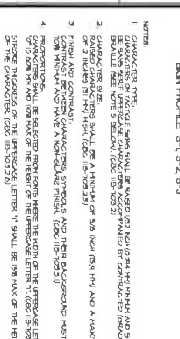
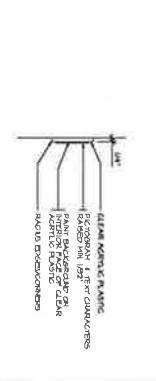
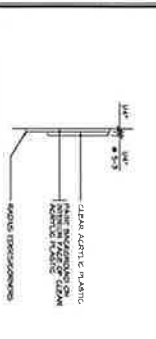
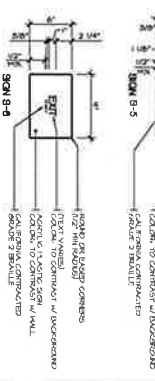
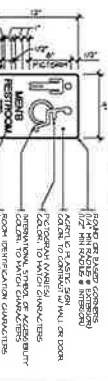
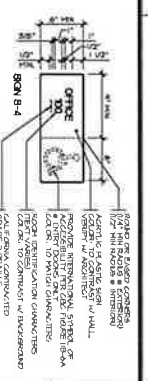
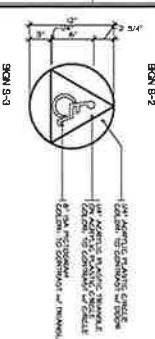
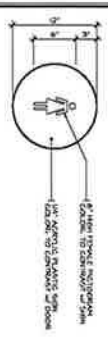
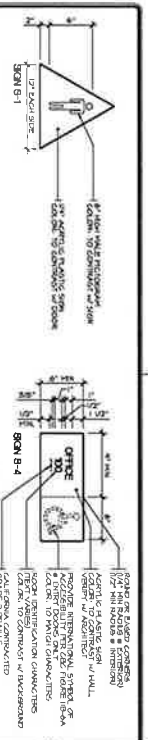

GRAB BAR DETAIL SCALE: 1/2" = 1'-0" ASSISTIVE LISTENING SIGN SCALE: 1/2" = 1'-0" TYPICAL TILE THRESHOLD SCALE: 1/2" = 1'-0" EYEFACE WASH STATION WALL MOUNT SCALE: 1/2" = 1'-0" ACCESSIBLE TOILET SCALE: 1/2" = 1'-0" ACCESSIBLE SINK AND CABINET SCALE: 1/2" = 1'-0" ACCESSIBLE WORK STATION SCALE: 1/2" = 1'-0" RECESSED TISSUE DISPENSER SCALE: 1/2" = 1'-0" TYPICAL MOUNTING HEIGHTS SCALE: 1/2" = 1'-0" SIGN LOCATIONS / MOUNTING SCALE: 1/2" = 1'-0" MAXIMUM OCCUPANCY SIGN SCALE: 1/2" = 1'-0"

Project Number  
17-0100  
Sheet Number  
AX3.1

Project Title  
MIRAL COUNTY PUBLIC WORKS  
BRAWLEY YARD BUILDING REPLACEMENT  
ACCESS COMPLIANCE DETAILS

Drawn Date  
04-06-18  
Date Last Revised

Sanders, INC.  
Architecture/Engineering  
102 INDUSTRY WAY, SUITE A  
EL CENTRO, CA 92243  
760 353 5440  
FAX 760 353 5442

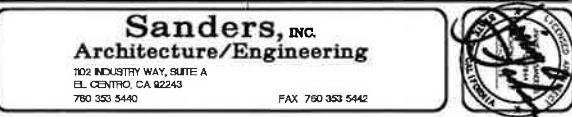

**GENERAL NOTES**

1. THE NOTES SPECIFIC TO THIS SHALL BE PART OF THE CONTRACT DOCUMENTS.
2. THE CONTRACTOR SHALL BE RESPONSIBLE FOR OBTAINING ALL NECESSARY PERMITS AND APPROVALS FROM THE LOCAL JURISDICTION.
3. THE CONTRACTOR SHALL BE RESPONSIBLE FOR OBTAINING ALL NECESSARY PERMITS AND APPROVALS FROM THE LOCAL JURISDICTION.
4. THE CONTRACTOR SHALL BE RESPONSIBLE FOR OBTAINING ALL NECESSARY PERMITS AND APPROVALS FROM THE LOCAL JURISDICTION.
5. THE CONTRACTOR SHALL BE RESPONSIBLE FOR OBTAINING ALL NECESSARY PERMITS AND APPROVALS FROM THE LOCAL JURISDICTION.
6. THE CONTRACTOR SHALL BE RESPONSIBLE FOR OBTAINING ALL NECESSARY PERMITS AND APPROVALS FROM THE LOCAL JURISDICTION.
7. THE CONTRACTOR SHALL BE RESPONSIBLE FOR OBTAINING ALL NECESSARY PERMITS AND APPROVALS FROM THE LOCAL JURISDICTION.
8. THE CONTRACTOR SHALL BE RESPONSIBLE FOR OBTAINING ALL NECESSARY PERMITS AND APPROVALS FROM THE LOCAL JURISDICTION.
9. THE CONTRACTOR SHALL BE RESPONSIBLE FOR OBTAINING ALL NECESSARY PERMITS AND APPROVALS FROM THE LOCAL JURISDICTION.
10. THE CONTRACTOR SHALL BE RESPONSIBLE FOR OBTAINING ALL NECESSARY PERMITS AND APPROVALS FROM THE LOCAL JURISDICTION.

**DESIGN BASIS**

1. DESIGN BASIS SHALL BE AS FOLLOWS:
2. DESIGN BASIS SHALL BE AS FOLLOWS:
3. DESIGN BASIS SHALL BE AS FOLLOWS:
4. DESIGN BASIS SHALL BE AS FOLLOWS:
5. DESIGN BASIS SHALL BE AS FOLLOWS:
6. DESIGN BASIS SHALL BE AS FOLLOWS:
7. DESIGN BASIS SHALL BE AS FOLLOWS:
8. DESIGN BASIS SHALL BE AS FOLLOWS:
9. DESIGN BASIS SHALL BE AS FOLLOWS:
10. DESIGN BASIS SHALL BE AS FOLLOWS:

**REQUIRED SPECIAL INSPECTIONS**

ITEM	REQUIRED	REMARKS
FOUNDATION	YES	
CONCRETE	YES	
STEEL	YES	
MECHANICAL	YES	
ELECTRICAL	YES	
PLUMBING	YES	
MECHANICAL	YES	
ELECTRICAL	YES	
PLUMBING	YES	

**CONCRETE**

1. ALL CONCRETE SHALL BE PLACED AND FINISHED IN ACCORDANCE WITH THE FOLLOWING:
2. ALL CONCRETE SHALL BE PLACED AND FINISHED IN ACCORDANCE WITH THE FOLLOWING:
3. ALL CONCRETE SHALL BE PLACED AND FINISHED IN ACCORDANCE WITH THE FOLLOWING:
4. ALL CONCRETE SHALL BE PLACED AND FINISHED IN ACCORDANCE WITH THE FOLLOWING:
5. ALL CONCRETE SHALL BE PLACED AND FINISHED IN ACCORDANCE WITH THE FOLLOWING:
6. ALL CONCRETE SHALL BE PLACED AND FINISHED IN ACCORDANCE WITH THE FOLLOWING:
7. ALL CONCRETE SHALL BE PLACED AND FINISHED IN ACCORDANCE WITH THE FOLLOWING:
8. ALL CONCRETE SHALL BE PLACED AND FINISHED IN ACCORDANCE WITH THE FOLLOWING:
9. ALL CONCRETE SHALL BE PLACED AND FINISHED IN ACCORDANCE WITH THE FOLLOWING:
10. ALL CONCRETE SHALL BE PLACED AND FINISHED IN ACCORDANCE WITH THE FOLLOWING:

**REINFORCING STEEL**

1. ALL REINFORCING STEEL SHALL BE PLACED AND FINISHED IN ACCORDANCE WITH THE FOLLOWING:
2. ALL REINFORCING STEEL SHALL BE PLACED AND FINISHED IN ACCORDANCE WITH THE FOLLOWING:
3. ALL REINFORCING STEEL SHALL BE PLACED AND FINISHED IN ACCORDANCE WITH THE FOLLOWING:
4. ALL REINFORCING STEEL SHALL BE PLACED AND FINISHED IN ACCORDANCE WITH THE FOLLOWING:
5. ALL REINFORCING STEEL SHALL BE PLACED AND FINISHED IN ACCORDANCE WITH THE FOLLOWING:
6. ALL REINFORCING STEEL SHALL BE PLACED AND FINISHED IN ACCORDANCE WITH THE FOLLOWING:
7. ALL REINFORCING STEEL SHALL BE PLACED AND FINISHED IN ACCORDANCE WITH THE FOLLOWING:
8. ALL REINFORCING STEEL SHALL BE PLACED AND FINISHED IN ACCORDANCE WITH THE FOLLOWING:
9. ALL REINFORCING STEEL SHALL BE PLACED AND FINISHED IN ACCORDANCE WITH THE FOLLOWING:
10. ALL REINFORCING STEEL SHALL BE PLACED AND FINISHED IN ACCORDANCE WITH THE FOLLOWING:

**LUMBER**

1. ALL LUMBER SHALL BE PLACED AND FINISHED IN ACCORDANCE WITH THE FOLLOWING:
2. ALL LUMBER SHALL BE PLACED AND FINISHED IN ACCORDANCE WITH THE FOLLOWING:
3. ALL LUMBER SHALL BE PLACED AND FINISHED IN ACCORDANCE WITH THE FOLLOWING:
4. ALL LUMBER SHALL BE PLACED AND FINISHED IN ACCORDANCE WITH THE FOLLOWING:
5. ALL LUMBER SHALL BE PLACED AND FINISHED IN ACCORDANCE WITH THE FOLLOWING:
6. ALL LUMBER SHALL BE PLACED AND FINISHED IN ACCORDANCE WITH THE FOLLOWING:
7. ALL LUMBER SHALL BE PLACED AND FINISHED IN ACCORDANCE WITH THE FOLLOWING:
8. ALL LUMBER SHALL BE PLACED AND FINISHED IN ACCORDANCE WITH THE FOLLOWING:
9. ALL LUMBER SHALL BE PLACED AND FINISHED IN ACCORDANCE WITH THE FOLLOWING:
10. ALL LUMBER SHALL BE PLACED AND FINISHED IN ACCORDANCE WITH THE FOLLOWING:

**PAINTING SCHEDULE**

ITEM	DESCRIPTION	UNIT	QUANTITY
1	PAINTING SCHEDULE		
2	PAINTING SCHEDULE		
3	PAINTING SCHEDULE		
4	PAINTING SCHEDULE		
5	PAINTING SCHEDULE		
6	PAINTING SCHEDULE		
7	PAINTING SCHEDULE		
8	PAINTING SCHEDULE		
9	PAINTING SCHEDULE		
10	PAINTING SCHEDULE		

**CLUED-LAMINATED BEAM**

1. ALL CLUED-LAMINATED BEAMS SHALL BE PLACED AND FINISHED IN ACCORDANCE WITH THE FOLLOWING:
2. ALL CLUED-LAMINATED BEAMS SHALL BE PLACED AND FINISHED IN ACCORDANCE WITH THE FOLLOWING:
3. ALL CLUED-LAMINATED BEAMS SHALL BE PLACED AND FINISHED IN ACCORDANCE WITH THE FOLLOWING:
4. ALL CLUED-LAMINATED BEAMS SHALL BE PLACED AND FINISHED IN ACCORDANCE WITH THE FOLLOWING:
5. ALL CLUED-LAMINATED BEAMS SHALL BE PLACED AND FINISHED IN ACCORDANCE WITH THE FOLLOWING:
6. ALL CLUED-LAMINATED BEAMS SHALL BE PLACED AND FINISHED IN ACCORDANCE WITH THE FOLLOWING:
7. ALL CLUED-LAMINATED BEAMS SHALL BE PLACED AND FINISHED IN ACCORDANCE WITH THE FOLLOWING:
8. ALL CLUED-LAMINATED BEAMS SHALL BE PLACED AND FINISHED IN ACCORDANCE WITH THE FOLLOWING:
9. ALL CLUED-LAMINATED BEAMS SHALL BE PLACED AND FINISHED IN ACCORDANCE WITH THE FOLLOWING:
10. ALL CLUED-LAMINATED BEAMS SHALL BE PLACED AND FINISHED IN ACCORDANCE WITH THE FOLLOWING:

**COMMON WALLS ONLY**

1. COMMON WALLS SHALL BE PLACED AND FINISHED IN ACCORDANCE WITH THE FOLLOWING:
2. COMMON WALLS SHALL BE PLACED AND FINISHED IN ACCORDANCE WITH THE FOLLOWING:
3. COMMON WALLS SHALL BE PLACED AND FINISHED IN ACCORDANCE WITH THE FOLLOWING:
4. COMMON WALLS SHALL BE PLACED AND FINISHED IN ACCORDANCE WITH THE FOLLOWING:
5. COMMON WALLS SHALL BE PLACED AND FINISHED IN ACCORDANCE WITH THE FOLLOWING:
6. COMMON WALLS SHALL BE PLACED AND FINISHED IN ACCORDANCE WITH THE FOLLOWING:
7. COMMON WALLS SHALL BE PLACED AND FINISHED IN ACCORDANCE WITH THE FOLLOWING:
8. COMMON WALLS SHALL BE PLACED AND FINISHED IN ACCORDANCE WITH THE FOLLOWING:
9. COMMON WALLS SHALL BE PLACED AND FINISHED IN ACCORDANCE WITH THE FOLLOWING:
10. COMMON WALLS SHALL BE PLACED AND FINISHED IN ACCORDANCE WITH THE FOLLOWING:



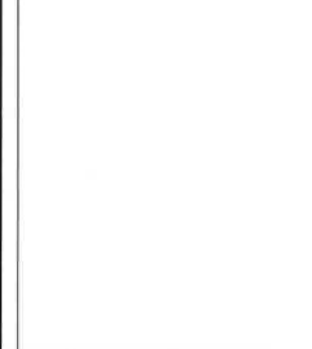
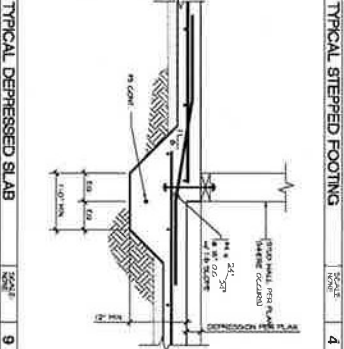
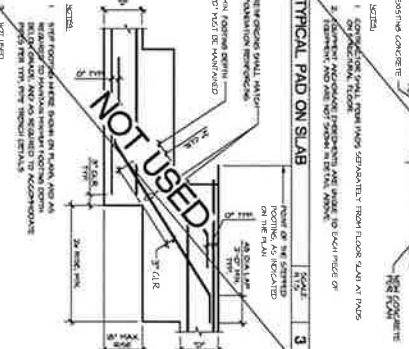
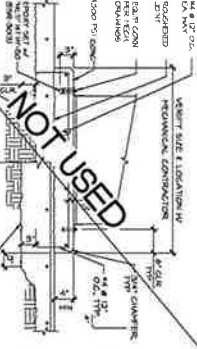
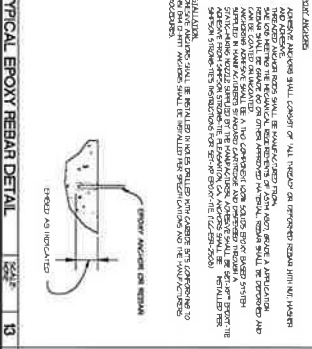
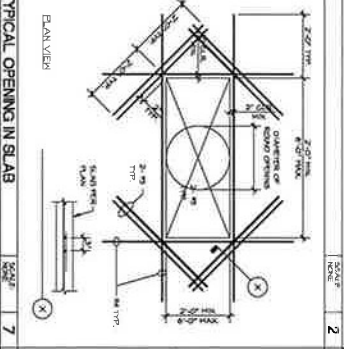
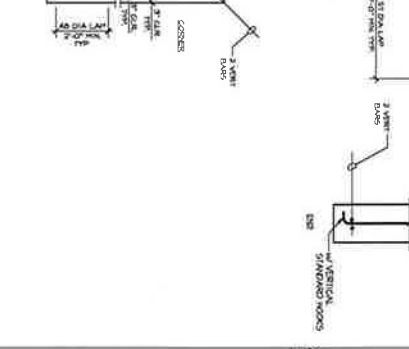
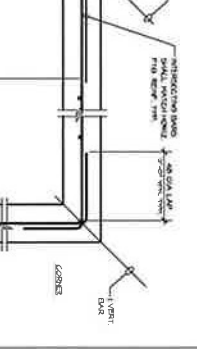
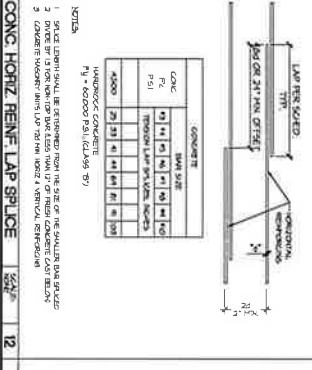
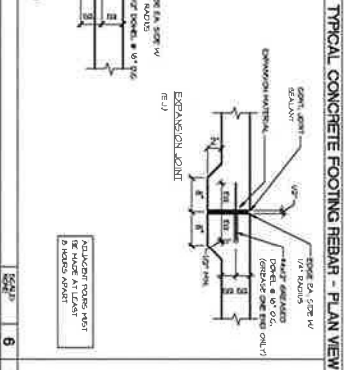
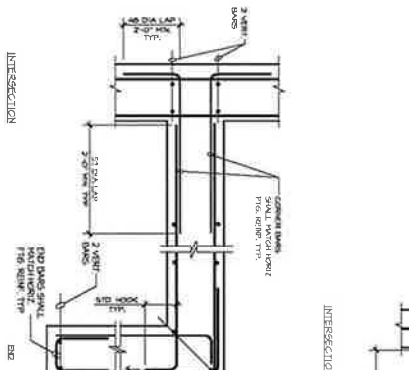
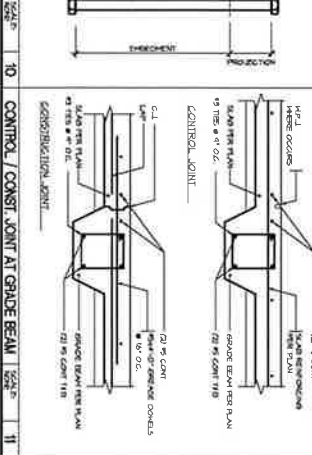
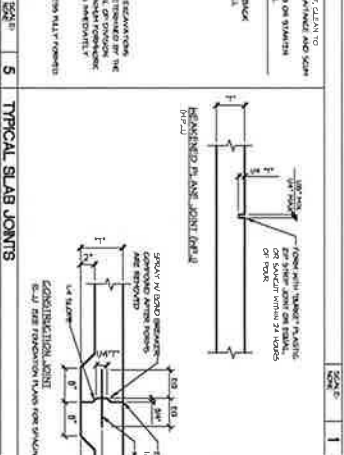
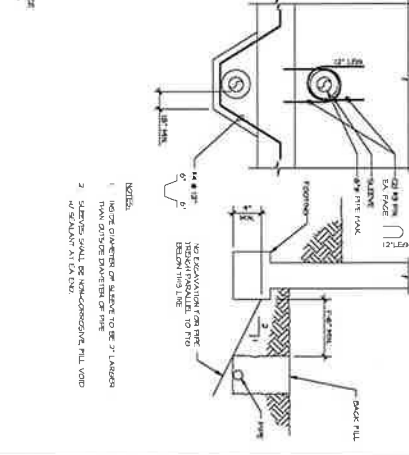
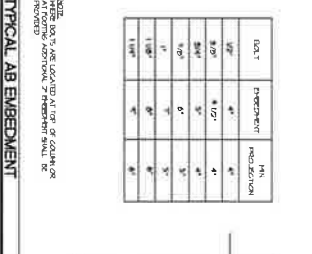
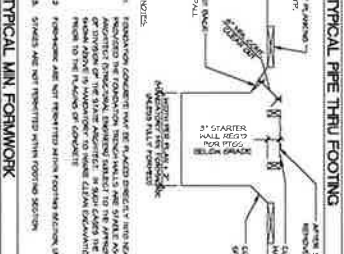
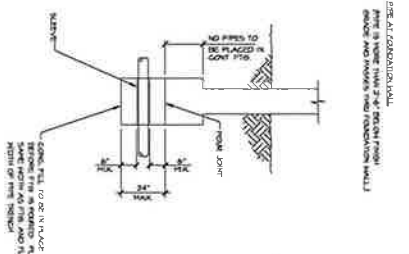
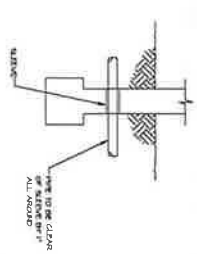

TYPICAL AB EMBEUREMENT SCALE 10  
 CONTROL / CONST. JOINT AT GRADE BEAM SCALE 11  
 CONC. HORIZ. REINF. LAP SPlice SCALE 12  
 TYPICAL EPOXY REBAR DETAIL SCALE 13  
 TYPICAL DEPRESSED SLAB SCALE 9  
 TYPICAL STEPPED FOOTING SCALE 4  
 TYPICAL PAD ON SLAB SCALE 3

NOTE: ALL REINFORCEMENT SHALL BE PLACED IN THE CENTER OF THE SLAB UNLESS OTHERWISE INDICATED.

BAR	SPACING	MIN. COVER
TOP	18"	2"
BOTTOM	18"	2"
WALL	18"	2"
SLAB	18"	2"
BEAM	18"	2"
FOOTING	18"	2"

NOTE: ALL REINFORCEMENT SHALL BE PLACED IN THE CENTER OF THE SLAB UNLESS OTHERWISE INDICATED.

BAR	SPACING	MIN. COVER
TOP	18"	2"
BOTTOM	18"	2"
WALL	18"	2"
SLAB	18"	2"
BEAM	18"	2"
FOOTING	18"	2"

NOTE: ALL REINFORCEMENT SHALL BE PLACED IN THE CENTER OF THE SLAB UNLESS OTHERWISE INDICATED.

BAR	SPACING	MIN. COVER
TOP	18"	2"
BOTTOM	18"	2"
WALL	18"	2"
SLAB	18"	2"
BEAM	18"	2"
FOOTING	18"	2"

NOTE: ALL REINFORCEMENT SHALL BE PLACED IN THE CENTER OF THE SLAB UNLESS OTHERWISE INDICATED.

BAR	SPACING	MIN. COVER
TOP	18"	2"
BOTTOM	18"	2"
WALL	18"	2"
SLAB	18"	2"
BEAM	18"	2"
FOOTING	18"	2"

NOTE: ALL REINFORCEMENT SHALL BE PLACED IN THE CENTER OF THE SLAB UNLESS OTHERWISE INDICATED.

BAR	SPACING	MIN. COVER
TOP	18"	2"
BOTTOM	18"	2"
WALL	18"	2"
SLAB	18"	2"
BEAM	18"	2"
FOOTING	18"	2"

Project Number: 17-010  
 Sheet Number: SO.2

Project Title: IMPERIAL COUNTY PUBLIC WORKS BRAWLEY YARD BUILDING REPLACEMENT  
 Sheet Title: STRUCTURAL DETAILS

Drawing Date: 04-06-10  
 Date Last Revised:

**Sanders, INC.**  
 Architecture/Engineering  
 100 INDUSTRY WAY, SUITE A  
 ESSEX, CALIFORNIA 92243  
 780 353 5440 FAX 760 353 5442







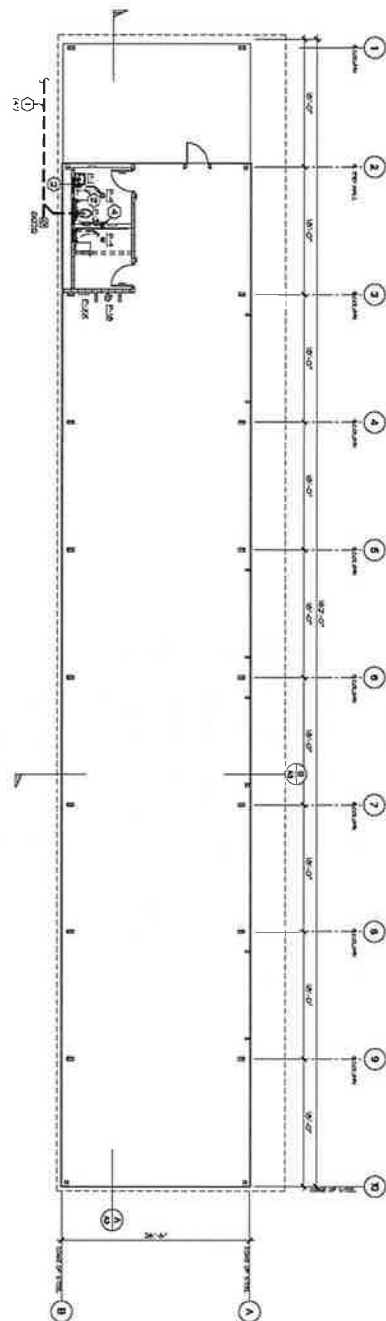

- WASTE AND VENT KEYNOTES**
- 1. FIELD VENT EXHAUST CONTROL CONNECT TO EXISTING SCREEN LINE
  - 2. FIELD VENT EXHAUST CONTROL CONNECT TO EXISTING SCREEN LINE
  - 3. FIELD VENT EXHAUST CONTROL CONNECT TO EXISTING SCREEN LINE
  - 4. FIELD VENT EXHAUST CONTROL CONNECT TO EXISTING SCREEN LINE
  - 5. FIELD VENT EXHAUST CONTROL CONNECT TO EXISTING SCREEN LINE
  - 6. FIELD VENT EXHAUST CONTROL CONNECT TO EXISTING SCREEN LINE
  - 7. FIELD VENT EXHAUST CONTROL CONNECT TO EXISTING SCREEN LINE
  - 8. FIELD VENT EXHAUST CONTROL CONNECT TO EXISTING SCREEN LINE
  - 9. FIELD VENT EXHAUST CONTROL CONNECT TO EXISTING SCREEN LINE
  - 10. FIELD VENT EXHAUST CONTROL CONNECT TO EXISTING SCREEN LINE

- NOTES**
- 1. ALL SPACES AND HALLS SHALL BE VENTED TO THE OUTSIDE.
  - 2. FIELD VENT EXHAUST CONTROL SHALL BE INSTALLED IN ALL SPACES AND HALLS.
  - 3. FIELD VENT EXHAUST CONTROL SHALL BE INSTALLED IN ALL SPACES AND HALLS.
  - 4. FIELD VENT EXHAUST CONTROL SHALL BE INSTALLED IN ALL SPACES AND HALLS.
  - 5. FIELD VENT EXHAUST CONTROL SHALL BE INSTALLED IN ALL SPACES AND HALLS.
  - 6. FIELD VENT EXHAUST CONTROL SHALL BE INSTALLED IN ALL SPACES AND HALLS.
  - 7. FIELD VENT EXHAUST CONTROL SHALL BE INSTALLED IN ALL SPACES AND HALLS.
  - 8. FIELD VENT EXHAUST CONTROL SHALL BE INSTALLED IN ALL SPACES AND HALLS.
  - 9. FIELD VENT EXHAUST CONTROL SHALL BE INSTALLED IN ALL SPACES AND HALLS.
  - 10. FIELD VENT EXHAUST CONTROL SHALL BE INSTALLED IN ALL SPACES AND HALLS.

**WASTE AND VENT**

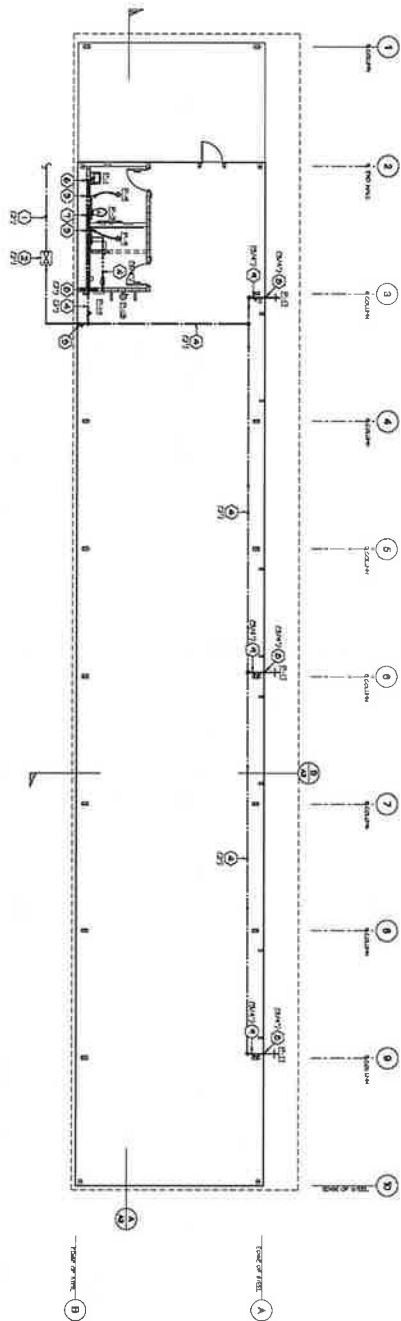

- NOT AND COLD WATER KEYNOTES**
- 1. HOT WATER SHALL BE SUPPLIED TO ALL SPACES AND HALLS.
  - 2. COLD WATER SHALL BE SUPPLIED TO ALL SPACES AND HALLS.
  - 3. HOT AND COLD WATER SHALL BE SUPPLIED TO ALL SPACES AND HALLS.
  - 4. HOT AND COLD WATER SHALL BE SUPPLIED TO ALL SPACES AND HALLS.
  - 5. HOT AND COLD WATER SHALL BE SUPPLIED TO ALL SPACES AND HALLS.
  - 6. HOT AND COLD WATER SHALL BE SUPPLIED TO ALL SPACES AND HALLS.
  - 7. HOT AND COLD WATER SHALL BE SUPPLIED TO ALL SPACES AND HALLS.
  - 8. HOT AND COLD WATER SHALL BE SUPPLIED TO ALL SPACES AND HALLS.
  - 9. HOT AND COLD WATER SHALL BE SUPPLIED TO ALL SPACES AND HALLS.
  - 10. HOT AND COLD WATER SHALL BE SUPPLIED TO ALL SPACES AND HALLS.

**HOT AND COLD WATER**

Project Number  
17-0100

Sheet Number  
**P1.0**

Project Title  
**IMPERIAL COUNTY PUBLIC WORKS  
BRAWLEY YARD BUILDING REPLACEMENT**

Sheet Title  
**WASTE-VENT, HOT/COLD WATER**

Revised Date  
04-06-18

Date Last Revised

**Sanders, INC.**  
Architecture/Engineering

102 INDUSTRY WAY, SUITE A  
EL CENTRO, CA 92243  
760 353 5440

FAX 760 353 5442











**POWER AND LIGHTING FLOOR PLAN**

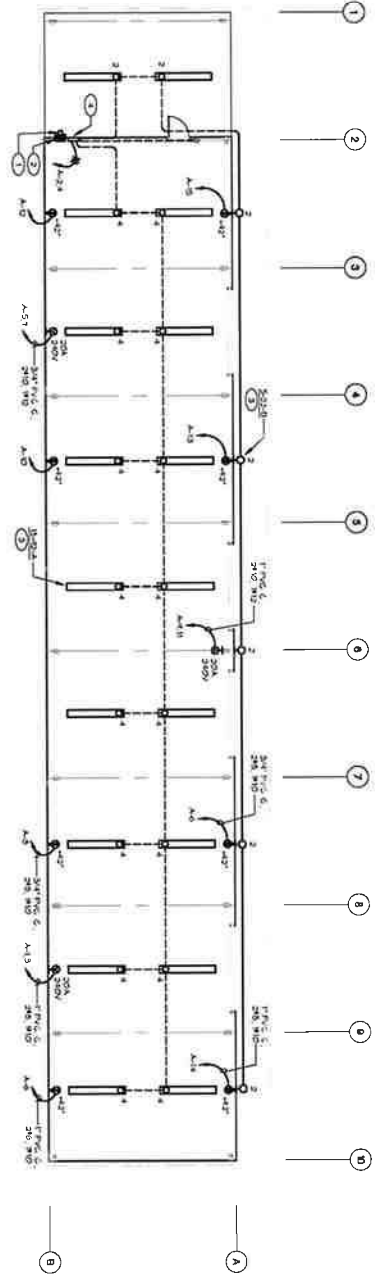

DATE: 11/27/10	REV: 1	DATE: 11/27/10	REV: 2	DATE: 11/27/10	REV: 3
PROJECT: 17-010	PROJECT: 17-010	PROJECT: 17-010	PROJECT: 17-010	PROJECT: 17-010	PROJECT: 17-010
DESCRIPTION: 17-010	DESCRIPTION: 17-010	DESCRIPTION: 17-010	DESCRIPTION: 17-010	DESCRIPTION: 17-010	DESCRIPTION: 17-010

LOCATION	TYPE	MANUFACTURER	MODEL	WATTAGE	HEIGHT	REMARKS
TRUCK LANE	1	GE	1500	1500	10	TRUCK LANE LIGHTING
TRUCK LANE	2	GE	1500	1500	10	TRUCK LANE LIGHTING
TRUCK LANE	3	GE	1500	1500	10	TRUCK LANE LIGHTING
TRUCK LANE	4	GE	1500	1500	10	TRUCK LANE LIGHTING
TRUCK LANE	5	GE	1500	1500	10	TRUCK LANE LIGHTING
TRUCK LANE	6	GE	1500	1500	10	TRUCK LANE LIGHTING
TRUCK LANE	7	GE	1500	1500	10	TRUCK LANE LIGHTING
TRUCK LANE	8	GE	1500	1500	10	TRUCK LANE LIGHTING
TRUCK LANE	9	GE	1500	1500	10	TRUCK LANE LIGHTING
TRUCK LANE	10	GE	1500	1500	10	TRUCK LANE LIGHTING
TRUCK LANE	11	GE	1500	1500	10	TRUCK LANE LIGHTING
TRUCK LANE	12	GE	1500	1500	10	TRUCK LANE LIGHTING
TRUCK LANE	13	GE	1500	1500	10	TRUCK LANE LIGHTING
TRUCK LANE	14	GE	1500	1500	10	TRUCK LANE LIGHTING
TRUCK LANE	15	GE	1500	1500	10	TRUCK LANE LIGHTING
TRUCK LANE	16	GE	1500	1500	10	TRUCK LANE LIGHTING
TRUCK LANE	17	GE	1500	1500	10	TRUCK LANE LIGHTING
TRUCK LANE	18	GE	1500	1500	10	TRUCK LANE LIGHTING
TRUCK LANE	19	GE	1500	1500	10	TRUCK LANE LIGHTING
TRUCK LANE	20	GE	1500	1500	10	TRUCK LANE LIGHTING
TRUCK LANE	21	GE	1500	1500	10	TRUCK LANE LIGHTING
TRUCK LANE	22	GE	1500	1500	10	TRUCK LANE LIGHTING
TRUCK LANE	23	GE	1500	1500	10	TRUCK LANE LIGHTING
TRUCK LANE	24	GE	1500	1500	10	TRUCK LANE LIGHTING
TRUCK LANE	25	GE	1500	1500	10	TRUCK LANE LIGHTING
TRUCK LANE	26	GE	1500	1500	10	TRUCK LANE LIGHTING
TRUCK LANE	27	GE	1500	1500	10	TRUCK LANE LIGHTING
TRUCK LANE	28	GE	1500	1500	10	TRUCK LANE LIGHTING
TRUCK LANE	29	GE	1500	1500	10	TRUCK LANE LIGHTING
TRUCK LANE	30	GE	1500	1500	10	TRUCK LANE LIGHTING
TRUCK LANE	31	GE	1500	1500	10	TRUCK LANE LIGHTING
TRUCK LANE	32	GE	1500	1500	10	TRUCK LANE LIGHTING
TRUCK LANE	33	GE	1500	1500	10	TRUCK LANE LIGHTING
TRUCK LANE	34	GE	1500	1500	10	TRUCK LANE LIGHTING
TRUCK LANE	35	GE	1500	1500	10	TRUCK LANE LIGHTING
TRUCK LANE	36	GE	1500	1500	10	TRUCK LANE LIGHTING
TRUCK LANE	37	GE	1500	1500	10	TRUCK LANE LIGHTING
TRUCK LANE	38	GE	1500	1500	10	TRUCK LANE LIGHTING
TRUCK LANE	39	GE	1500	1500	10	TRUCK LANE LIGHTING
TRUCK LANE	40	GE	1500	1500	10	TRUCK LANE LIGHTING
TRUCK LANE	41	GE	1500	1500	10	TRUCK LANE LIGHTING
TRUCK LANE	42	GE	1500	1500	10	TRUCK LANE LIGHTING
TRUCK LANE	43	GE	1500	1500	10	TRUCK LANE LIGHTING
TRUCK LANE	44	GE	1500	1500	10	TRUCK LANE LIGHTING
TRUCK LANE	45	GE	1500	1500	10	TRUCK LANE LIGHTING
TRUCK LANE	46	GE	1500	1500	10	TRUCK LANE LIGHTING
TRUCK LANE	47	GE	1500	1500	10	TRUCK LANE LIGHTING
TRUCK LANE	48	GE	1500	1500	10	TRUCK LANE LIGHTING
TRUCK LANE	49	GE	1500	1500	10	TRUCK LANE LIGHTING
TRUCK LANE	50	GE	1500	1500	10	TRUCK LANE LIGHTING
TRUCK LANE	51	GE	1500	1500	10	TRUCK LANE LIGHTING
TRUCK LANE	52	GE	1500	1500	10	TRUCK LANE LIGHTING
TRUCK LANE	53	GE	1500	1500	10	TRUCK LANE LIGHTING
TRUCK LANE	54	GE	1500	1500	10	TRUCK LANE LIGHTING
TRUCK LANE	55	GE	1500	1500	10	TRUCK LANE LIGHTING
TRUCK LANE	56	GE	1500	1500	10	TRUCK LANE LIGHTING
TRUCK LANE	57	GE	1500	1500	10	TRUCK LANE LIGHTING
TRUCK LANE	58	GE	1500	1500	10	TRUCK LANE LIGHTING
TRUCK LANE	59	GE	1500	1500	10	TRUCK LANE LIGHTING
TRUCK LANE	60	GE	1500	1500	10	TRUCK LANE LIGHTING
TRUCK LANE	61	GE	1500	1500	10	TRUCK LANE LIGHTING
TRUCK LANE	62	GE	1500	1500	10	TRUCK LANE LIGHTING
TRUCK LANE	63	GE	1500	1500	10	TRUCK LANE LIGHTING
TRUCK LANE	64	GE	1500	1500	10	TRUCK LANE LIGHTING
TRUCK LANE	65	GE	1500	1500	10	TRUCK LANE LIGHTING
TRUCK LANE	66	GE	1500	1500	10	TRUCK LANE LIGHTING
TRUCK LANE	67	GE	1500	1500	10	TRUCK LANE LIGHTING
TRUCK LANE	68	GE	1500	1500	10	TRUCK LANE LIGHTING
TRUCK LANE	69	GE	1500	1500	10	TRUCK LANE LIGHTING
TRUCK LANE	70	GE	1500	1500	10	TRUCK LANE LIGHTING
TRUCK LANE	71	GE	1500	1500	10	TRUCK LANE LIGHTING
TRUCK LANE	72	GE	1500	1500	10	TRUCK LANE LIGHTING
TRUCK LANE	73	GE	1500	1500	10	TRUCK LANE LIGHTING
TRUCK LANE	74	GE	1500	1500	10	TRUCK LANE LIGHTING
TRUCK LANE	75	GE	1500	1500	10	TRUCK LANE LIGHTING
TRUCK LANE	76	GE	1500	1500	10	TRUCK LANE LIGHTING
TRUCK LANE	77	GE	1500	1500	10	TRUCK LANE LIGHTING
TRUCK LANE	78	GE	1500	1500	10	TRUCK LANE LIGHTING
TRUCK LANE	79	GE	1500	1500	10	TRUCK LANE LIGHTING
TRUCK LANE	80	GE	1500	1500	10	TRUCK LANE LIGHTING
TRUCK LANE	81	GE	1500	1500	10	TRUCK LANE LIGHTING
TRUCK LANE	82	GE	1500	1500	10	TRUCK LANE LIGHTING
TRUCK LANE	83	GE	1500	1500	10	TRUCK LANE LIGHTING
TRUCK LANE	84	GE	1500	1500	10	TRUCK LANE LIGHTING
TRUCK LANE	85	GE	1500	1500	10	TRUCK LANE LIGHTING
TRUCK LANE	86	GE	1500	1500	10	TRUCK LANE LIGHTING
TRUCK LANE	87	GE	1500	1500	10	TRUCK LANE LIGHTING
TRUCK LANE	88	GE	1500	1500	10	TRUCK LANE LIGHTING
TRUCK LANE	89	GE	1500	1500	10	TRUCK LANE LIGHTING
TRUCK LANE	90	GE	1500	1500	10	TRUCK LANE LIGHTING
TRUCK LANE	91	GE	1500	1500	10	TRUCK LANE LIGHTING
TRUCK LANE	92	GE	1500	1500	10	TRUCK LANE LIGHTING
TRUCK LANE	93	GE	1500	1500	10	TRUCK LANE LIGHTING
TRUCK LANE	94	GE	1500	1500	10	TRUCK LANE LIGHTING
TRUCK LANE	95	GE	1500	1500	10	TRUCK LANE LIGHTING
TRUCK LANE	96	GE	1500	1500	10	TRUCK LANE LIGHTING
TRUCK LANE	97	GE	1500	1500	10	TRUCK LANE LIGHTING
TRUCK LANE	98	GE	1500	1500	10	TRUCK LANE LIGHTING
TRUCK LANE	99	GE	1500	1500	10	TRUCK LANE LIGHTING
TRUCK LANE	100	GE	1500	1500	10	TRUCK LANE LIGHTING

\* - NOTE CHECK THROUGH TITLE 24 APPROVE OF THE CLOCK WITH AERONAUTIC FIXTURE AND 2 HOUR OF BRIDGE

FIXTURE	MANUFACTURER	CATALOG NUMBER	WATTAGE	HEIGHT	REMARKS
A	GE	1500	1500	10	TRUCK LANE LIGHTING
B	GE	1500	1500	10	TRUCK LANE LIGHTING



**NOTES**

- 1) REFER TO
- 2) PANEL NO.
- 3) REFER TO THE CLOCK

**GENERAL NOTES**

REFER TO THE CLOCK WITH AERONAUTIC FIXTURE AND 2 HOUR OF BRIDGE

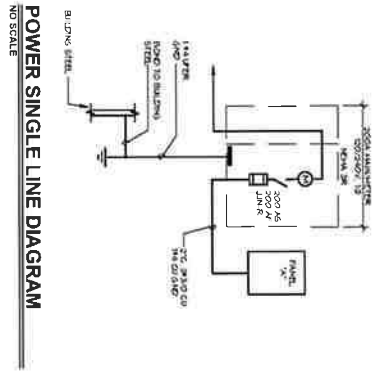

**POWER SINGLE LINE DIAGRAM**  
NO SCALE



Project Number: 17-010  
Sheet Number: E2.1

Project Title: IMPERIAL COUNTY PUBLIC WORKS BRAWLEY YARD BUILDING REPLACEMENT  
Sheet Title: POWER + LIGHTING FLOOR PLAN, SINGLE LINE, PANEL

Drawn Date: 01-06-17  
Date Last Revised:

**Sanders, INC.**  
Architecture/Engineering  
162 INDUSTRY WAY, SUITE A  
EL CENTRO, CA 92243  
760 353 5440 FAX 760 353 5442









**EXHIBIT D**

**SAMPLE AGREEMENT FOR SERVICE**

**IMPERIAL COUNTY BRAWLEY ROAD YARD REPLACEMENT  
4736 STATE HWY-111, BRAWLEY, CA. 92227  
COUNTY PROJECT NO. SR5901ADM**



1 **AGREEMENT FOR CONSTRUCTION SERVICES**

2 **«Contractor\_Business\_Name»**

3 THIS AGREEMENT FOR CONSTRUCTION SERVICES (“Agreement”), made and entered  
4 into effective the \_\_\_\_ day of \_\_\_\_\_, 2021, by and between the COUNTY OF IMPERIAL, a  
5 political subdivision of the State of California, through its Department of Public Works (“COUNTY”)  
6 and **«Contractor\_Business\_Name»**, a «Contractor\_Business\_Type» licensed to do business within the  
7 state of California (“CONTRACTOR”) (individually, “Party;” collectively, “Parties”) shall be as  
8 follows:

9 **RECITALS**

10 **WHEREAS**, COUNTY desires to retain a qualified individual, firm or business entity to provide  
11 professional construction services for Imperial County Project Number «Project\_Number»,  
12 «Project\_Name» (“Project”); and

13 **WHEREAS**, COUNTY wishes to engage CONTRACTOR for performance of such services as  
14 are provided for herein and CONTRACTOR is willing to accept such engagement.

15 **NOW, THEREFORE**, COUNTY and CONTRACTOR have and hereby agree to the following:

16 **1. DEFINITIONS.**

17 **1.1.** “Invitation for Bid” shall mean the document entitled, “«Name\_of\_RFP»,” dated  
18 «Date\_of\_RFP», which includes all special notices, addendums, exhibits and Plans and  
19 Specifications as defined in Paragraph 1.3. The Invitation for Bid is attached hereto as  
20 **Exhibit “A”** and incorporated herein as though fully set forth.

21 **1.2.** “Proposal” shall mean CONTRACTOR’s document entitled “«Name\_of\_Proposal»,”  
22 dated «Date\_of\_Proposal» and submitted to the Clerk of the Board. The Proposal is  
23 attached hereto as **Exhibit “B”** and incorporated herein as though fully set forth.

24 **1.3.** “Plans and Specifications” shall mean the plans and specifications approved by the  
25 Director of Public Works, or his/her designee, for Project Number «Project\_Number».  
26 While COUNTY is responsible for the completeness and accuracy of the Plans and  
27 Specifications for the Project, CONTRACTOR is required to review the Plans and  
28 Specifications and promptly report any errors or omissions to COUNTY.

1 **2. CONTRACT COORDINATION.**

2 **2.1.** The Director of Public Works or his/her designee shall be the representative of COUNTY  
3 for all purposes under this Agreement. The Director of Public Works or his/her designee  
4 is hereby designated as the Contract Manager for COUNTY. He/she shall supervise the  
5 progress and execution of this Agreement.

6 **2.2.** CONTRACTOR shall assign a single Contract Manager to have overall responsibility for  
7 the progress and execution of this Agreement. Should circumstances or conditions  
8 subsequent to the execution of this Agreement require a substitute Contract Manager for  
9 any reason, the Contract Manager designee shall be subject to the prior written acceptance  
10 and approval of COUNTY's Contract Manager.

11 **3. SCOPE OF WORK TO BE PERFORMED BY CONTRACTOR.**

12 **3.1.** CONTRACTOR shall furnish all work, labor, tools, equipment, materials, supervision,  
13 scheduling, coordination and contract administration necessary to construct and complete  
14 the Project in a good, expeditious, workman-like and substantial manner under the terms  
15 of and in full and complete compliance with this Agreement ("Work").

16 **3.2.** CONTRACTOR shall comply with and perform work consistent with all terms,  
17 conditions and requirements of the Plans, Specifications, the Invitation for Bids and this  
18 Agreement.

19 **3.3.** All described work shall be constructed, installed, placed and performed in conformance  
20 with the Plans and Specifications and all Special Provisions contained therein and as  
21 directed by COUNTY's engineer.

22 **3.4.** In the event of a conflict among this Agreement, the Invitation for Bid and the Proposal,  
23 the Invitation for Bid shall take precedence over the Proposal and this Agreement shall  
24 take precedence over both.

25 **3.5.** CONTRACTOR shall perform such other tasks as necessary and proper for the full  
26 performance of the obligations assumed by CONTRACTOR hereunder; including but not  
27 limited to any additional work or change orders agreed upon pursuant to written  
28 authorization as described in Section 5. Proposed additional work or change order

1 requests, when applicable, will be attached and incorporated herein under **Exhibit “B”**  
2 (as “B-1,” “B-2,” etc.).

3 **4. TRENCHING REQUIREMENTS AND UTILITY RELOCATION.**

4 **4.1. Four Feet (4’) Below the Surface.** In the event the Project involves digging trenches or  
5 other excavations that extend deeper than four feet (4’) below the surface,  
6 CONTRACTOR shall:

7 **4.1.1.** Promptly, and before the following conditions are disturbed, notify COUNTY, in  
8 writing, of any:

- 9 (a) Material that CONTRACTOR believes may be material that is hazardous  
10 waste, as defined in Health & Safety Code §25117, that is required to be  
11 removed to a Class I, Class II or Class III disposal site in accordance with  
12 provisions of existing law;
- 13 (b) Subsurface or latent physical conditions at the site differing from those  
14 indicated by information about the site made available to bidders prior to  
15 the deadline for submitting bids; and
- 16 (c) Unknown physical conditions at the site of any unusual nature, different  
17 materially from those ordinarily encountered and generally recognized as  
18 inherent in work of the character provided for in the Agreement.

19 **4.1.2.** In response to any written notice generated pursuant to Subparagraph 4.1.1,  
20 COUNTY shall promptly investigate the conditions, and if it finds that the  
21 conditions do materially so differ, or do involve hazardous waste, and cause a  
22 decrease or increase in CONTRACTOR’s cost of, or the time required for,  
23 performance of any part of the Work, COUNTY shall issue a change order under  
24 the procedures described in this Agreement.

25 **4.1.3.** In the event that a dispute arises between COUNTY and CONTRACTOR whether  
26 the conditions materially differ, or involve hazardous waste, or cause a decrease  
27 or increase in CONTRACTOR’s cost of, or time required for, performance of any  
28 part of the Work, CONTRACTOR shall not be excused from any scheduled



1 completion date provided for by this Agreement, but shall proceed with all Work  
2 to be performed under this Agreement. CONTRACTOR shall retain any and all  
3 rights provided either by contract or by law which pertain to the resolution of  
4 disputes and protests between the Parties.

5 **4.2. Trenching Requirements – Project in Excess of Twenty-Five Thousand Dollars (\$25,000)**  
6 **and Five Feet (5') Below the Surface.** For projects involving both an estimated  
7 expenditure in excess of twenty-five thousand dollars (\$25,000) and the excavation of  
8 any trench five feet (5') or more in depth, CONTRACTOR shall submit a detailed plan  
9 showing the design of shoring, bracing, sloping or other provisions to be made for worker  
10 protection from the hazard of caving ground during the excavation of such trench. The  
11 plan must be accepted by COUNTY (or by a registered civil or structural engineer,  
12 employed by COUNTY, to whom authority to accept has been delegated) in advance of  
13 excavation. If such plan varies from the shoring system standards, the plan shall be  
14 prepared by a registered civil or structural engineer. Nothing in this Paragraph shall allow  
15 CONTRACTOR to use a shoring, sloping, or protective system less effective than that  
16 required by California Construction Safety Orders. Further, nothing in this Paragraph  
17 shall be construed to impose tort liability on COUNTY or any of its employees.

18 **4.3. Utilities Relocation.** In the event that CONTRACTOR, in the scope of work, encounters  
19 utilities not shown on COUNTY'S plans, COUNTY shall compensate CONTRACTOR  
20 for utilities relocation work. COUNTY shall also waive liquidated damages for any delay  
21 that occurs as a result of said encounter and/or relocation of utilities.

22 **5. CHANGE ORDERS.**

23 **5.1. Change Orders.** CONTRACTOR shall make no changes to the Work to be performed  
24 pursuant to this Agreement, including but not limited to additions, deletions,  
25 modifications or substitutions, nor shall CONTRACTOR perform any extra work  
26 (collectively, "Change Order Work") without the prior written consent of COUNTY. If  
27 CONTRACTOR encounters conditions it considers different from those described in  
28 **Exhibit "A"** to this Agreement, CONTRACTOR may request a change order in

1 conformance with COUNTY's standard procedure ("Change Order"). If COUNTY  
2 approves the request, CONTRACTOR will execute a Change Order and  
3 CONTRACTOR's execution of the Change Order shall confirm approval thereof.  
4 COUNTY may order additional work, and CONTRACTOR shall perform such changes  
5 in the Work as directed by COUNTY in any Change Order prepared by CONTRACTOR.  
6 COUNTY's rights to eliminate portions of the Work or to initiate a Change Order shall  
7 not be limited in any way. The Change Order shall be in writing and shall include:

8 **5.1.1.** Any and all supporting documents and drawings depicting the source and location  
9 of the desired change, and explain in detail the field conditions and reasons for  
10 the requested change;

11 **5.1.2.** Any change or adjustment to the compensation set forth in this Agreement as a  
12 result of changes in the Work based on a lump sum or time and material basis, as  
13 may be directed by COUNTY; and

14 **5.1.3.** Any request for adjustments to time for completion of the Project.

15 **5.2.** Payment for Change Order Work. CONTRACTOR shall not be entitled to receive any  
16 compensation for work, labor, materials or changes of any kind, regardless of whether  
17 ordered by COUNTY or any of its representatives, unless a Change Order has been  
18 submitted in writing and approved prior to the commencement of any Change Order  
19 Work as described above. If the changes are required by any inspecting governmental  
20 agencies or utility companies, or are otherwise required to comply with any codes, laws,  
21 rules or regulations, including those set forth in this Agreement, then CONTRACTOR  
22 shall not be entitled to any increases in the compensation set forth in this Agreement or  
23 other compensation as a result of the changes.

24 **5.3.** Disputed Change Order Work. Any dispute concerning the performance of such Change  
25 Order Work or the amount of compensation to be paid to CONTRACTOR by COUNTY  
26 shall not affect CONTRACTOR's obligation to perform such Change Order Work.  
27 CONTRACTOR agrees that it shall timely complete all Change Order Work even if there  
28 shall be a dispute between CONTRACTOR and COUNTY over the amount or scope of

1 the Change Order Work. CONTRACTOR shall have the right to be compensated for any  
2 undisputed Change Order Work amounts as determined to be undisputed in COUNTY's  
3 sole discretion.

4 **5.4. Authorized Representative.** No Change Order shall be valid or binding against COUNTY  
5 unless such Change Order has been executed by COUNTY's designated representative,  
6 who is the Director of Public Works. COUNTY shall notify CONTRACTOR in writing  
7 if the designated representative is changed.

8 **5.5. Limits.** When applicable, the authority to execute a Change Order on this Project shall  
9 not exceed the amount allowed by law pursuant to Public Contract Code sections 20137-  
10 20142 et seq. Where Change Orders are in an amount between ten percent (10%) and  
11 twenty-five percent (25%) of the amount set forth in this Agreement and based on a need  
12 for additional quantities due to an increase in the unit quantities required to complete the  
13 project in excess of the COUNTY's Engineer's estimate of unit quantities as set forth in  
14 the Invitation to Bid, CONTRACTOR shall be paid pursuant to Public Contract Code  
15 sections 20143 and 20139 and section 4 of the Standard Specifications, State of  
16 California, Business, Transportation and Housing Agency, May 2006 Issued by the  
17 Department of Transportation ("Caltrans Standard Specifications") referred to in **Exhibit**  
18 **"A"** and incorporated herein by reference.

19 **6. REPRESENTATIONS BY CONTRACTOR.**

20 **6.1.** CONTRACTOR understands and agrees that COUNTY has limited knowledge in the  
21 construction specified in the description of work. CONTRACTOR has represented itself  
22 to be expert in these fields and understands that COUNTY is relying upon such  
23 representation.

24 **6.2.** CONTRACTOR represents and warrants that it is a lawful entity possessing all required  
25 licenses and authorities to do business in the State of California and perform all aspects  
26 of this Agreement.

27 **6.3.** CONTRACTOR shall not commence any work under this Agreement or provide any  
28 other services, or materials, in connection therewith until CONTRACTOR has received

1 written authorization from the Director of Public Works, or his/her designee (“Notice to  
2 Proceed”) to do so.

3 **6.4.** CONTRACTOR represents and warrants that the people executing this Agreement on  
4 behalf of CONTRACTOR have the authority of CONTRACTOR to sign this Agreement  
5 and bind CONTRACTOR to the performance of all duties and obligations assumed by  
6 CONTRACTOR herein.

7 **6.5.** CONTRACTOR represents and warrants that any employee, contractor, subcontractor  
8 and agent who will be performing any of the duties and obligations of CONTRACTOR  
9 herein possess all required licenses and authorities, as well as the experience and training,  
10 to perform such tasks.

11 **6.6.** CONTRACTOR represents and warrants that the allegations contained in its Proposal are  
12 true and correct.

13 **6.7.** CONTRACTOR understands that COUNTY considers the representations made herein  
14 to be material and would not enter into this Agreement with CONTRACTOR if such  
15 representations were not made.

16 **6.8.** Retention and Access of Books and Records. CONTRACTOR represents and warrants  
17 that it shall maintain books, records, documents, reports and other materials developed  
18 under this Agreement as follows:

19 **6.8.1.** CONTRACTOR shall hold and possess as the property of COUNTY all papers,  
20 books, files, correspondence and other records of all kinds which at any time shall  
21 come into its possession or under its control relating only to services performed  
22 by CONTRACTOR under this Agreement for a minimum period of five (5) years,  
23 or for any longer period required by law, from the date said papers came into the  
24 possession of CONTRACTOR pursuant to this Agreement.

25 **6.8.2.** Any records or documents required to be maintained by CONTRACTOR  
26 pursuant to this Agreement shall be made available to COUNTY for inspection or  
27 audit, at any time during CONTRACTOR’s regular business hours provided  
28 COUNTY provides CONTRACTOR with seven (7) days advanced written or oral

1 notice. Copies of such documents shall, at no cost to COUNTY, be provided to  
2 COUNTY for inspection at CONTRACTOR's address indicated for receipt of  
3 notices under this Agreement.

4 **6.8.3.** CONTRACTOR shall surrender all papers maintained by CONTRACTOR  
5 pursuant to Subparagraph 6.8.1 of this Agreement within thirty (30) days of  
6 termination of this Agreement.

7 **6.8.4.** CONTRACTOR represents and warrants that it has not been engaged by, nor will  
8 it be engaged by and owes no duty of performance to any other person or entity  
9 that would constitute a conflict. For breach or violation of this warranty,  
10 COUNTY shall amongst other remedies at law, have the right to terminate this  
11 Agreement without liability, or at its sole discretion, to deduct from the  
12 Agreement price or consideration, or otherwise recover the full amount of such  
13 fee, commission, percentage brokerage fee, gift or contingent fee paid or received  
14 from another entity or person.

15 **6.9.** CONTRACTOR shall perform pursuant to this Agreement in accordance with and in full  
16 compliance with all applicable Federal, State and local statues, rules, regulations and  
17 policies and procedures, regardless of whether they are expressly set forth in this  
18 Agreement. It is understood that in the event COUNTY is investigated or audited by any  
19 State or Federal governmental agency, or any other recognized investigative/auditing  
20 entity, CONTRACTOR shall fully cooperate with such agencies' reasonable and lawful  
21 request for information.

22 **7. TERM OF AGREEMENT.**

23 This Agreement shall commence on the date first written above and shall remain in effect until  
24 the services provided as outlined in Section 3, ("SCOPE OF WORK TO BE PERFORMED BY  
25 CONTRACTOR"), have been completed, unless otherwise terminated as provided for in this Agreement.

26 **8. COMPENSATION.**

27 The total compensation payable under this Agreement shall be in accordance with the item prices  
28 incorporated within the Proposal submitted by CONTRACTOR for labor, materials and all other services

1 related to the performance of this Agreement, attached hereto as **Exhibit “B”** and incorporated herein  
2 as though fully set forth. The total compensation payable under this Agreement shall not exceed  
3 «**Cost\_of\_Original\_Contract**».

4 **9. PAYMENT AND RETENTION OF FUNDS.**

5 COUNTY shall pay CONTRACTOR for completed and approved services upon presentation  
6 and approval of its itemized billing, subject to the following.

7 **9.1. Retention.**

8 **9.1.1.** In accordance with Cal. Pub. Contract Code §§ 7201 and 9203, COUNTY shall  
9 generally retain five percent (5%) of the total compensation payable under this  
10 Agreement until the Work to be performed has been completed in accordance with  
11 this Agreement, as determined by COUNTY, and payment in full of all of  
12 CONTRACTOR’s subcontractors has been certified.

13 **9.1.2.** The 5% retention amount may be exceeded if the COUNTY’s Board of  
14 Supervisors has approved a finding, during a properly noticed and normally  
15 scheduled public hearing conducted either prior to or concurrent with authorizing  
16 this Project to go out to bid, that the Project is substantially complex and therefore  
17 requires a higher retention amount than 5%. Should the retention amount exceed  
18 5% for this Project, then the actual retention amount will be listed in the Plans and  
19 Specifications, along with the findings justifying the increased retention amount.

20 **9.2. Substitution of Retention.**

21 **9.2.1.** CONTRACTOR may elect to substitute securities for any retention of funds by  
22 COUNTY to ensure performance under this Agreement. At the request and  
23 expense of CONTRACTOR, securities equivalent to the amount retained shall be  
24 deposited with the COUNTY, or with a state or federally chartered bank in this  
25 state as the escrow agent, who shall then return the securities to CONTRACTOR  
26 once the Work to be performed has been completed in accordance with this  
27 Agreement, as determined by COUNTY, and payment in full of all of  
28 CONTRACTOR’s subcontractors has been certified.

1           **9.2.2.** Alternatively, CONTRACTOR may request and COUNTY shall make payment  
2 of retentions earned directly to the escrow agent at the expense of  
3 CONTRACTOR. CONTRACTOR, at its sole cost and expense, may direct the  
4 investment of the payments into securities, and CONTRACTOR shall receive the  
5 interest earned on the investments upon the same terms provided for in this  
6 Section for securities deposited by CONTRACTOR. Once the Work to be  
7 performed has been completed in accordance with this Agreement, as determined  
8 by COUNTY, and payment in full of all of CONTRACTOR's subcontractors has  
9 been certified, CONTRACTOR shall receive from the escrow agent all securities,  
10 interest, and payments received by the escrow agent from COUNTY, pursuant to  
11 the terms of this Section.

12           **9.2.3.** Securities eligible for investment under this Section shall include those listed in  
13 Cal. Gov. Code § 16430, bank or savings and loan certificates of deposit, interest-  
14 bearing demand deposit accounts, standby letters of credit, or any other security  
15 mutually agreed to by COUNTY and CONTRACTOR. CONTRACTOR shall be  
16 the beneficial owner of any securities substituted for retained funds and shall  
17 receive any interest thereon.

18           **9.2.4.** Substitution of securities shall be conducted through an Escrow Agreement  
19 substantially similar to that found in Cal. Pub. Contract Code § 22300(f).

20           **9.2.5.** Notwithstanding any other provision in this Section, substitution of securities is  
21 prohibited where funding for the Project, in whole or in part, will be provided by  
22 the Farmers Home Administration of the United States Department of Agriculture  
23 pursuant to the Consolidated Farm and Rural Development Act (7 U.S.C. Sec.  
24 1921 et seq.), or where otherwise disallowed by federal law.

25 **10. METHOD OF PAYMENT.**

26           **10.1.** CONTRACTOR shall at any time prior to the fifteenth (15<sup>th</sup>) day of any month, submit  
27 to COUNTY's Director of Public Works or his/her designee, a complete and accurate  
28 written claim for compensation for services performed. The claim shall be in a format

1 approved by COUNTY. COUNTY shall make no payment prior to the claims being  
2 approved in writing by the Director of Public Works or his/her designee.

3 **10.2.** After determining that the claim is a proper payment request, the Director of Public  
4 Works, or his/her designee, shall submit to COUNTY's Auditor/Controller undisputed  
5 and properly submitted claims approved for payment within ten (10) days following the  
6 date the claim was submitted to his/her Department.

7 **10.3.** CONTRACTOR may expect to receive payment within a reasonable time thereafter and  
8 in any event in the normal course of business within thirty (30) days after the undisputed  
9 and properly submitted claim is submitted.

10 **10.4.** Any claim determined to be an improper payment request shall be returned to  
11 CONTRACTOR as soon as practicable, but not later than seven (7) days, after receipt  
12 with a written explanation as to why the claim is an improper request for payment.

13 **10.5.** In order for prompt payment to be made by COUNTY pursuant to Public Contract Code  
14 §20104.50, CONTRACTOR must properly fill out all written claims for compensation  
15 for services performed.

16 **10.6.** COUNTY shall pay interest at the legal rate set forth in Code of Civil Procedure §685.010  
17 in the event payment is not made within thirty (30) days of an undisputed properly  
18 submitted request.

19 **11. INDEMNIFICATION.**

20 **11.1.** CONTRACTOR agrees to the fullest extent permitted by law to indemnify, defend,  
21 protect and hold COUNTY and its representatives, officers, directors, designees,  
22 employees, agents, successors and assigns harmless from any and all claims, expenses,  
23 liabilities, causes of action, demands, losses, penalties, attorneys' fees and costs, in law  
24 or equity, of every kind and nature whatsoever arising out of or in connection with  
25 CONTRACTOR's negligent acts and omissions or willful misconduct under this  
26 Agreement ("Claims"), whether or not arising from the passive negligence of COUNTY,  
27 but does not include Claims that are finally determined to be the result of the sole  
28 negligence or willful misconduct of COUNTY.



1           **11.2.** CONTRACTOR agrees to defend with counsel acceptable to COUNTY, indemnify and  
2 hold COUNTY harmless from all Claims, including but not limited to:

3           **11.2.1.** Personal injury, including but not limited to bodily injury, emotional injury,  
4 sickness or disease or death to persons including but not limited to COUNTY's  
5 representatives, officers, directors, designees, employees, agents, successors and  
6 assigns, subcontractors and other third parties and/or damage to property of  
7 anyone (including loss of use thereof) arising out of CONTRACTOR's negligent  
8 performance of, or willful misconduct surrounding, any of the terms contained in  
9 this Agreement, or anyone directly or indirectly employed by CONTRACTOR or  
10 anyone for whose acts CONTRACTOR may be liable;

11           **11.2.2.** Liability arising from injuries to CONTRACTOR and/or any of  
12 CONTRACTOR's employees or agents arising out of CONTRACTOR's  
13 negligent performance of, or willful misconduct surrounding, any of the terms  
14 contained in this Agreement, or anyone directly or indirectly employed by  
15 CONTRACTOR or anyone for whose acts CONTRACTOR may be liable;

16           **11.2.3.** Penalties imposed upon account of the violation of any law, order, citation, rule,  
17 regulation, standard, ordinance or statute caused by the negligent action or  
18 inaction, or willful misconduct of CONTRACTOR or anyone directly or  
19 indirectly employed by CONTRACTOR or anyone for whose acts  
20 CONTRACTOR may be liable, including but not limited to:

21           **(a)** Any loss of funding, penalties, fees, or other costs resulting from  
22 CONTRACTOR's failure to adhere to Disadvantaged Business Enterprise  
23 requirements and/or goals, as determined by COUNTY or such other  
24 lawful entity in charge of monitoring Disadvantaged Business Enterprise  
25 compliance;

26           **(b)** Any loss of funding, penalties, fees, or other costs resulting from  
27 CONTRACTOR's failure to adhere to prevailing wage requirements, as  
28 determined by COUNTY, the California Department of Industrial

1 Relations, or such other lawful entity in charge of monitoring prevailing  
2 wage compliance;

3 **11.2.4.** Infringement of any patent rights which may be brought against COUNTY arising  
4 out of CONTRACTOR's work;

5 **11.2.5.** Any violation or infraction by CONTRACTOR of any law, order, citation, rule,  
6 regulation, standard, ordinance or statute in any way relating to the occupational  
7 health or safety of employees; and

8 **11.2.6.** Any breach by CONTRACTOR of the terms, requirements or covenants of this  
9 Agreement.

10 **11.3.** The indemnification provisions of this Agreement shall extend to Claims occurring after  
11 this Agreement is terminated, as well as while it is in force.

12 **12. INDEPENDENT CONTRACTOR.**

13 **12.1.** In all situations and circumstances arising out of the terms and conditions of this  
14 Agreement, CONTRACTOR is an independent contractor, and as an independent  
15 contractor, the following shall apply:

16 **12.2.** CONTRACTOR is not an employee or agent of COUNTY and is only responsible for the  
17 requirements and results specified by this Agreement.

18 **12.3.** CONTRACTOR shall be responsible to COUNTY only for the requirements and results  
19 specified by this Agreement and except as specifically provided in this Agreement, shall  
20 not be subject to COUNTY's control with respect to the physical actions or activities of  
21 CONTRACTOR in fulfillment of the requirements of this Agreement.

22 **12.4.** CONTRACTOR is not, and shall not be, entitled to receive from, or through, COUNTY,  
23 and COUNTY shall not provide, or be obligated to provide, CONTRACTOR with  
24 Worker's Compensation coverage or any other type of employment or worker insurance  
25 or benefit coverage required or provided by any Federal, State or local law or regulation  
26 for, or normally afforded to, an employee of COUNTY.

27 **12.5.** CONTRACTOR shall not be entitled to have COUNTY withhold or pay, and COUNTY  
28 shall not withhold or pay, on behalf of CONTRACTOR, any tax or money relating to the

1 Social Security Old Age Pension Program, Social Security Disability Program, or any  
2 other type of pension, annuity, or disability program required or provided by any Federal,  
3 State or local law or regulation.

4 **12.6.** CONTRACTOR shall not be entitled to participate in, or receive any benefit from, or  
5 make any claim against any COUNTY fringe benefit program, including, but not limited  
6 to, COUNTY's pension plan, medical and health care plan, dental plan, life insurance  
7 plan, or any other type of benefit program, plan, or coverage designated for, provided to,  
8 or offered to COUNTY's employee.

9 **12.7.** COUNTY shall not withhold or pay, on behalf of CONTRACTOR, any Federal, State,  
10 or local tax, including, but not limited to, any personal income tax, owed by  
11 CONTRACTOR.

12 **12.8.** CONTRACTOR is, and at all times during the term of this Agreement shall represent and  
13 conduct itself as, an independent contractor, not an employee of COUNTY.

14 **12.9.** CONTRACTOR shall not have the authority, express or implied, to act on behalf of, bind  
15 or obligate COUNTY in any way without the written consent of COUNTY.

16 **13. INSURANCE.**

17 **13.1.** CONTRACTOR hereby agrees at its own cost and expense to procure and maintain,  
18 during the entire term of this Agreement and any extended term therefore, insurance in a  
19 sum acceptable to COUNTY and adequate to cover potential liabilities arising in  
20 connection with the performance of this Agreement and in any event not less than the  
21 minimum limit set forth in the "Minimum Insurance Amounts" attachment to the Plans  
22 and Specifications which are incorporated as if set forth fully herein.

23 **13.2. Special Insurance Requirements.** All insurance required shall:

24 **13.2.1.** Be procured from California admitted insurers (licensed to do business in  
25 California) with a current rating by Best's Key Rating Guide, acceptable to  
26 COUNTY. A rating of at least A-VII shall be acceptable to COUNTY; lesser  
27 ratings must be approved in writing by COUNTY.

28 **13.2.2.** Be primary coverage as respects COUNTY and any insurance or self-insurance

1 maintained by COUNTY shall be in excess of CONTRACTOR's insurance  
2 coverage and shall not contribute to it.

3 **13.2.3.** Name COUNTY as an additional insured on all policies, except Workers'  
4 Compensation, and provide that COUNTY may recover for any loss suffered by  
5 COUNTY by reason of CONTRACTOR's negligence.

6 **13.2.4.** State that it is primary insurance and regards COUNTY as an additional insured  
7 and contains a cross-liability or severability of interest clause.

8 **13.2.5.** Not be canceled, non-renewed or reduced in scope of coverage until after thirty  
9 (30) days written notice has been given to COUNTY. However, CONTRACTOR  
10 may not terminate such coverage until it provides COUNTY with proof that equal  
11 or better insurance has been secured and is in place. Cancellation or change  
12 without the prior written consent of COUNTY shall, at the option of COUNTY,  
13 be grounds for termination of this Agreement.

14 **13.2.6.** If this Agreement remains in effect more than one (1) year from the date of its  
15 original execution, COUNTY may, at its sole discretion, require an increase in the  
16 amount of liability insurance to the level then customary in similar COUNTY  
17 Agreements by giving sixty (60) days notice to CONTRACTOR.

18 **13.3. Additional Insurance Requirements.**

19 **13.3.1.** COUNTY is to be notified immediately of all insurance claims. COUNTY is also  
20 to be notified if any aggregate insurance limit is exceeded.

21 **13.3.2.** The comprehensive or commercial general liability shall contain a provision of  
22 endorsements stating that such insurance:

- 23 (a) Includes contractual liability;
- 24 (b) Does not contain any exclusions as to loss or damage to property caused  
25 by explosion or resulting from collapse of buildings or structures or  
26 damage to property underground, commonly referred to by insurers as the  
27 "XCU Hazards";
- 28 (c) Does not contain a "pro rata" provision which looks to limit the insurer's

1 liability to the total proportion that its policy limits bear to the total  
2 coverage available to the insured;

3 (d) Does not contain an “excess only” clause which requires the exhaustion  
4 of other insurance prior to providing coverage;

5 (e) Does not contain an “escape clause” which extinguishes the insurer’s  
6 liability if the loss is covered by other insurance;

7 (f) Includes COUNTY as an additional insured; and

8 (g) States that it is primary insurance and regards COUNTY as an additional  
9 insured and contains a cross-liability or severability of interest clause.

10 **13.4. Deposit of Insurance Policy.** Promptly on issuance, reissuance, or renewal of any  
11 insurance policy required by this Agreement, CONTRACTOR shall, if requested by  
12 COUNTY, cause to be given to COUNTY satisfactory evidence that insurance policy  
13 premiums have been paid together with a duplicate copy of the policy or a certificate  
14 evidencing the policy and executed by the insurance company issuing the policy or its  
15 authorized agent.

16 **13.5. Certificates of Insurance.** Complete copies of certificates of insurance for all required  
17 coverages including additional insured endorsements shall be attached hereto as **Exhibit**  
18 **“C”** and incorporated herein as though fully set forth.

19 **13.6. Additional Insurance.** Nothing in this, or any other provision of this Agreement, shall be  
20 construed to preclude CONTRACTOR from obtaining and maintaining any additional  
21 insurance policies in addition to those required pursuant to this Agreement.

22 **14. WORKERS’ COMPENSATION CERTIFICATION.**

23 **14.1.** Prior to the commencement of work, CONTRACTOR shall sign and file with COUNTY  
24 the following certification: “I am aware of the provisions of California Labor Code  
25 §§3700 et seq. which require every employer to be insured against liability for workers’  
26 compensation or to undertake self-insurance in accordance with the provisions of that  
27 code, and I will comply with such provisions before commencing the performance of the  
28 work of this contract.”

1 14.2. This certification is included in this Agreement and signature of the Agreement shall  
2 constitute signing and filing of the certificate.

3 14.3. CONTRACTOR understands and agrees that any and all employees, regardless of hire  
4 date, shall be covered by Workers' Compensation pursuant to statutory requirements  
5 prior to beginning work on the Project.

6 14.4. If CONTRACTOR has no employees, initial here: \_\_\_\_\_.

7 **15. WARRANTY.**

8 15.1. One Year Warranty. CONTRACTOR agrees to provide a one-year warranty for all of its  
9 work and component parts and guarantees that all work shall be performed in a  
10 professional and workman-like manner and be free from defects. CONTRACTOR  
11 guarantees to timely correct all work performed by it under this Agreement which  
12 COUNTY determines to be defective in design, material and/or workmanship within a  
13 period of one (1) year from the date of the completion of the Work. The warranties set  
14 forth in this Agreement shall be in addition to, and not in lieu of, all other statutory and  
15 case law warranties and obligations of CONTRACTOR. CONTRACTOR expressly  
16 agrees that all warranties made by CONTRACTOR, all obligations under this Agreement  
17 and all remedies for breach of such warranties shall survive this Agreement in the event  
18 it is terminated or expires for any reason prior to the running of the full warranty periods  
19 listed above.

20 15.2. Materials. All materials furnished by CONTRACTOR shall be new, manufactured  
21 during the current year, of first quality and carrying full manufacturer's warranty.  
22 CONTRACTOR shall be responsible for any expiration of manufacturer or other  
23 warranties of material or equipment being supplied for this Agreement. CONTRACTOR  
24 guarantees that all warranties of material and equipment shall become effective when the  
25 project is accepted by COUNTY's Board of Supervisors, not at time of installation by  
26 CONTRACTOR.

27 15.3. Manufacturers' Warranty Information. CONTRACTOR agrees to promptly provide such  
28 information and maintenance recommendations to COUNTY at the inception of

1 CONTRACTOR's work to the extent such information is reasonably available.

2 **16. DEFAULT AND REMEDIES.**

3 **16.1. Default.** In the event that (i) CONTRACTOR files a petition requesting relief under any  
4 bankruptcy act, or is adjudged as bankrupt, or makes a general assignment for the benefit  
5 of creditors or has a receiver appointed on account of its insolvency, or (ii)  
6 CONTRACTOR refuses or is unable, for whatever reason, to supply enough properly  
7 skilled workers or proper materials to complete the Project, or (iii) CONTRACTOR fails  
8 to follow the directions of COUNTY, or (iv) CONTRACTOR fails to make prompt  
9 payment to its subcontractors and suppliers for materials or labor supplied or permits any  
10 lien to be imposed upon all or any portion of the Project, or (v) CONTRACTOR  
11 disregards any laws or orders of any public or private authority having jurisdiction over  
12 the Work or the Project, or (vi) CONTRACTOR fails to perform in accordance with any  
13 of the terms of this Agreement or breaches any provision of this Agreement, COUNTY  
14 may give notice of such failure or breach to CONTRACTOR, identifying the failure or  
15 breach of this Agreement. Should any such failure or breach continue for twenty-four  
16 (24) hours after delivery of notice without a good faith effort on the part of  
17 CONTRACTOR to commence all necessary corrective action, or should such a breach  
18 continue despite CONTRACTOR's efforts for forty-eight (48) hours, then at that time  
19 such failure shall be deemed a default by CONTRACTOR under this Agreement and  
20 COUNTY shall have all rights and remedies available at law or in equity, including the  
21 right to terminate this Agreement. Without limiting its rights and remedies, COUNTY  
22 may then proceed as follows:

23 **16.1.1.** Without terminating this Agreement or the obligations of CONTRACTOR  
24 hereunder as to all of the Work required to be performed or furnished by  
25 CONTRACTOR pursuant to this Agreement, COUNTY may require  
26 CONTRACTOR, at CONTRACTOR's expense, to cure such default(s) as may  
27 exist in the performance of CONTRACTOR's obligations hereunder within forty-  
28 eight (48) hours after such default(s) has/have occurred including but not limited

1 to repairing, replacing and correcting material or Work determined by COUNTY  
2 to be defective or not complying with the requirements of this Agreement. Should  
3 CONTRACTOR fail to timely repair, replace and/or correct non-complying or  
4 defective materials and workmanship or otherwise cure its default(s) hereunder,  
5 and in the case of emergencies in which case COUNTY may act immediately if  
6 CONTRACTOR is not available or is not responding, and without further notice,  
7 COUNTY may make required repairs, replacements and other corrections or  
8 otherwise remedy the default by CONTRACTOR pursuant to the subparagraph  
9 below.

10 **16.1.2.** Without terminating this Agreement or the obligations of CONTRACTOR  
11 hereunder as to all of the Work required to be performed or furnished by  
12 CONTRACTOR pursuant to this Agreement, COUNTY may engage another  
13 contractor to perform such portion of CONTRACTOR's Work required pursuant  
14 to this Agreement or furnish any materials or other items required hereunder as  
15 COUNTY in its sole discretion may deem necessary to avoid delay in the progress  
16 of the Work, and in connection therewith, COUNTY may perform such Work or  
17 any portion thereof itself or have the same performed by others and COUNTY  
18 may procure all necessary materials, equipment or other items required for the  
19 continued progress of such Work. The costs incurred by COUNTY as a result of  
20 engaging another contractor shall be deducted from the compensation payable  
21 pursuant to this Agreement and if COUNTY's costs exceed or may reasonably be  
22 anticipated to exceed the balance of the compensation due to CONTRACTOR for  
23 such work, such excess, or anticipated excess, shall be immediately due and owing  
24 from CONTRACTOR to COUNTY and may be withheld from any funds due to  
25 CONTRACTOR pursuant to this Agreement or any other agreement.

26 **16.1.3.** COUNTY may terminate CONTRACTOR's right to perform upon written notice  
27 and COUNTY shall then have the option of completing the Work or any portion  
28 thereof by exercise of its interest under the performance bond issued in favor by



1 CONTRACTOR, or having such Work in whole or in part be completed by others  
2 for CONTRACTOR's account. A calculation shall take place at the conclusion  
3 of the Project wherein to the degree the sum of COUNTY's costs and any amounts  
4 paid to complete the Project exceed the compensation payable pursuant to this  
5 Agreement, then any such excess shall be immediately due and owing from  
6 CONTRACTOR to COUNTY.

7 **16.2. Damages.** CONTRACTOR shall be liable for all damages suffered by COUNTY by  
8 reason of CONTRACTOR's default in any provision of this Agreement and the exercise  
9 of COUNTY of its option to terminate this Agreement shall not release CONTRACTOR  
10 of such liability. CONTRACTOR shall have no right to receive any further payment after  
11 a default has occurred until such time as the Work to be performed by CONTRACTOR  
12 pursuant hereto has been completed and accepted by COUNTY and damages suffered by  
13 COUNTY, if any, ascertained. Damages shall include by way of illustration, but not of  
14 exclusion, COUNTY's costs of completing the Work which exceeds the compensation  
15 payable pursuant to this Agreement, other general, liquidated, special or consequential  
16 damages, attorney fees and costs.

17 **16.3. Actions After Default.** Should COUNTY exercise any of its options, remedies or rights  
18 granted pursuant to the terms of this Agreement in the event of a default by  
19 CONTRACTOR, COUNTY at its sole election may, but shall not be obligated to, use  
20 any materials, supplies, tools or equipment on the work site which belong to  
21 CONTRACTOR to complete the Work required to be completed by CONTRACTOR,  
22 whether such work is completed by COUNTY or by others, and CONTRACTOR agrees  
23 that it shall not remove such materials, supplies, tools and equipment from the work site  
24 unless directed in writing by COUNTY to do so.

25 **16.4. Limit on Force Majeure Damages.** CONTRACTOR shall not be responsible for repairing  
26 or restoring damage to work caused by an act of God in excess of five (5) percent of the  
27 contract amount, provided that the work damaged is built in accordance with accepted  
28 and applicable building standards and the plans and specifications of COUNTY. In the

1 event of such damage, COUNTY may, at its option, elect to terminate this Agreement.  
2 For purposes of this Agreement, an “act of God” shall be defined as an earthquake in  
3 excess of 3.5 on the Richter Scale and a tidal wave.

4 **16.5. Resolution of Claims.** COUNTY and CONTRACTOR agree to follow and comply with  
5 the mediation, arbitration, claim, civil action procedure and trial de novo provisions set  
6 forth in California Public Contracts Code §§ 9204 and 20104 – 20104.6.

7 **16.6. No Limitation of Rights.** The options and rights granted to COUNTY herein shall not be  
8 deemed as limitations upon the other rights and remedies of COUNTY in the event of a  
9 failure of performance or breach by CONTRACTOR, and COUNTY shall be entitled to  
10 exercise the rights and remedies hereinabove specified and all other rights and remedies  
11 which may be provided in this Agreement or by law or in equity, either cumulatively or  
12 consecutively, and in such order as COUNTY in its sole discretion shall determine.

13 **17. NON-DISCRIMINATION.**

14 **17.1.** During the performance of this Agreement, CONTRACTOR and its subcontractors shall  
15 not unlawfully discriminate, harass or allow harassment against any employee or  
16 applicant for employment because of sex, race, color, ancestry, religious creed, national  
17 origin, physical disability (including HIV and AIDS), mental disability, medical  
18 condition (cancer), age (over forty (40)), marital status and denial of family care leave.

19 **17.2.** CONTRACTOR and its subcontractors shall insure that the evaluation and treatment of  
20 their employees and applicants for employment are free from such discrimination and  
21 harassment.

22 **17.3.** CONTRACTOR and its subcontractors shall comply with the provisions of the Fair  
23 Employment and Housing Act (Gov. Code §12990 (a-f) et seq.) and the applicable  
24 regulations promulgated thereunder (California Code of Regulations, Title 2, Section  
25 7285 et seq.).

26 **17.4.** The applicable regulations of the Fair Employment and Housing Commission  
27 implementing Government Code §12990 (a-f), set forth in Chapter 5 of Division 4 of  
28 Title 2 of the California Code of Regulations, are incorporated into this Agreement by

1 reference and made a part hereof as if set forth in full.

2 **17.5.** The applicable regulations of Section 504 of the Rehabilitation Act of 1973 (29 U.S.C.  
3 §794 (a)) are incorporated into this Agreement by reference and made a part hereof as if  
4 set forth in full.

5 **17.6.** CONTRACTOR and its subcontractors shall give written notice of their obligations under  
6 this clause to labor organizations with which they have a collective bargaining or other  
7 agreement.

8 **17.7.** CONTRACTOR shall include the nondiscrimination and compliance provisions of this  
9 clause in all subcontracts to perform Work under this Agreement.

10 **18. DISADVANTAGED BUSINESS ENTITY COMPLIANCE.**

11 **18.1.** When applicable, CONTRACTOR and its subcontractors shall reference and abide by  
12 the guidance and Disadvantaged Business Enterprise (“DBE”) specifications contained  
13 in the California Department of Transportation’s Standard Specifications.

14 **18.2.** CONTRACTOR represents and warrants that is has fully read the applicable DBE  
15 requirements pertaining to this Project and has fully and accurately completed any and  
16 all required DBE forms.

17 **18.3.** CONTRACTOR represents and warrants that it will comply with all applicable DBE  
18 requirements for this Project.

19 **18.4.** CONTRACTOR shall comply with the applicable DBE provisions attached hereto as  
20 **Exhibit “D”** and incorporated by this reference as though fully set forth herein.

21 **18.5.** If any state or federal funds are withheld from COUNTY or not reimbursed to COUNTY  
22 due to CONTRACTOR’s failure to either comply with the DBE requirements set forth in  
23 the RFP and this Agreement, or to meet the mandatory DBE goals as determined by  
24 COUNTY, Caltrans, the Federal Highway Administration, and/or any other state or  
25 federal agency contributing funds to the Project, then CONTRACTOR shall fully  
26 reimburse COUNTY the amount of funding lost. COUNTY reserves the right to deduct  
27 any such loss in funding from the amount of compensation due to CONTRACTOR under  
28 this Agreement.

1           **18.6.** In addition to the above, CONTRACTOR's failure to comply with DBE  
2 requirements/goals shall subject it to such sanctions as are permitted by law, which may  
3 include, but shall not be limited to the following:

4           **18.6.1.** Termination of this Agreement;

5           **18.6.2.** Withholding monthly progress payments;

6           **18.6.3.** Denial of payment for any portion of the Project that was committed at the time  
7 of the execution of this Agreement to be performed by a DBE subcontractor, but  
8 was completed by CONTRACTOR or a substitute non-DBE subcontractor;

9           **18.6.4.** Compensatory, special, incidental, liquidated and other damages; and/or

10           **18.6.5.** Designation of CONTRACTOR as "nonresponsible," and disqualification from  
11 bidding on future public works projects advertised by COUNTY.

12 **19.    PREVAILING WAGE.**

13           **19.1.** CONTRACTOR and its subcontractors shall pay all workers employed on the Project the  
14 higher of either the rates determined by the Director of the California Department of  
15 Industrial Relations ("DIR") or, when applicable, the Davis-Bacon Federal wage rates as  
16 supplemented by the Department of Labor regulations. The Davis-Bacon Federal wage  
17 rates are attached to the RFP. Copies of the State prevailing rate of per diem wages are  
18 on file with the Department of Industrial Relations, Division of Apprenticeship Standards,  
19 445 Golden Gate Avenue, San Francisco, California, and at COUNTY's Department of  
20 Public Works, and are available to CONTRACTOR and any other interested party upon  
21 request. CONTRACTOR shall post the prevailing rate of per diem wages to be posted at  
22 the Project site.

23           **19.2.** CONTRACTOR is responsible for compliance with the provisions herein.

24           **19.3.   Mandatory Registration with the Department of Industrial Relations – NEW**  
25           **REQUIREMENTS PURSUANT TO SB 854.**

26           **19.3.1.** CONTRACTOR and its subcontractors shall register with the DIR and pay all  
27 applicable fees as set forth in Labor Code section 1725.5.

28           **19.3.2.** CONTRACTOR and its subcontractors acknowledge that they shall not be listed

1 on any bid proposal for a public works project (submitted on or after March 1,  
2 2015) unless registered with the DIR pursuant to Labor Code section 1725.5. The  
3 requirements of this section shall apply unless one of the limited exceptions  
4 provided under Labor Code Section 1771.1(a) applies.

5 **19.3.3.** CONTRACTOR and its subcontractors acknowledge that they shall not be  
6 awarded any contract for public work on a public works project (awarded on or  
7 after April 1, 2015) unless registered with the DIR pursuant to Labor Code section  
8 1725.5.

9 **19.3.4.** The Project described herein is subject to compliance monitoring and enforcement  
10 with the DIR.

11 **19.3.5.** For further information concerning compliance with SB 854, please visit:  
12 <http://www.dir.ca.gov/Public-Works/SB854.html>.

13 **19.4. Cognizance of Violations by County.**

14 **19.4.1.** CONTRACTOR understands and agrees that COUNTY shall take cognizance of  
15 violations of Chapter 1 of Part 7 of Division 2 of the California Labor Code  
16 committed in the course of the execution of this Agreement, and shall promptly  
17 report any suspected violations to the Labor Commissioner.

18 **19.4.2.** If CONTRACTOR determines as a result of its own investigation that there has  
19 been a violation of Chapter 1 of Part 7 of Division 2 of the California Labor Code  
20 and withholds payment to CONTRACTOR, the procedures in California Labor  
21 Code §1771.6 shall be followed.

22 **19.4.3.** CONTRACTOR may bring an action in a court of competent jurisdiction to  
23 recover from COUNTY the difference between the wages actually paid to an  
24 employee and the wages that were required to be paid to an employee pursuant to  
25 Chapter 1 of Part 7 of Division 2 of the California Labor Code, any penalties  
26 required to be paid pursuant to Chapter 1 of Part 7 of Division 2 of the California  
27 Labor Code, and costs and attorney's fees related to the action, if either of the  
28 following is true:

- 1 (a) COUNTY previously affirmatively represented to CONTRACTOR in  
2 writing, in the call for bids, or otherwise, that the Work was not a “public  
3 work,” as defined in Chapter 1 of Part 7 of Division 2 of the California  
4 Labor Code; or
- 5 (b) COUNTY received actual written notice from the Department of  
6 Industrial Relations that the Work is a “public work,” as defined in  
7 Chapter 1 of Part 7 of Division 2 of the California Labor Code, and failed  
8 to disclose that information to CONTRACTOR before the bid opening or  
9 award.

10 **19.5. Labor Compliance Rates and Payroll Records.**

11 **19.5.1.** CONTRACTOR agrees to comply with §§1775 and 1776 of the California Labor  
12 Code relating to the payment of prevailing wage and the maintenance of certified  
13 payroll records and to make the certified payroll records available for inspection  
14 at all reasonable hours at CONTRACTOR’s principal office. The responsibility  
15 for compliance with these provisions is fixed with CONTRACTOR.  
16 CONTRACTOR understands and agrees that it shall, as a penalty to COUNTY,  
17 forfeit specific monetary fines for each worker paid less than the prevailing wage  
18 rates as determined by the Labor Commissioner for the work or craft in which the  
19 worker is employed for any Work done pursuant to this Agreement.

20 **19.5.2.** *Prevailing Wage Compliance For those Projects subject to DIR Monitoring and*  
21 *Enforcement.* CONTRACTOR has reviewed and agrees to comply with any  
22 applicable provisions for those Projects subject to Department of Industrial  
23 Relations (DIR) Monitoring and Enforcement of prevailing wages. COUNTY  
24 hereby notifies CONTRACTOR that CONTRACTOR is responsible for  
25 complying with the requirements of Senate Bill 854 (SB854) regarding certified  
26 payroll record reporting. Further information concerning the requirements of  
27 SB854 is available on the DIR website located at: [http://www.dir.ca.gov/Public-](http://www.dir.ca.gov/Public-Works/PublicWorksEnforcement.html)  
28 [Works/PublicWorksEnforcement.html](http://www.dir.ca.gov/Public-Works/PublicWorksEnforcement.html).

1           **19.5.3.** CONTRACTOR shall be liable for penalties pursuant to this section when a  
2 subcontractor on the Project fails to pay its workers the general prevailing rate of  
3 per diem wages and any of the following conditions are met:

4           **(a)** CONTRACTOR had knowledge of that failure of the subcontractor to pay  
5 the specified prevailing rate of wages to those workers; or

6           **(b)** CONTRACTOR fails to comply with the following requirement: The  
7 contract executed between CONTRACTOR and the subcontractor for the  
8 performance of Work on the Project shall include a copy of the provisions  
9 of California Labor Code §§1771, 1775, 1776, 1777.5, 1813 and 1815;  
10 and

11           **(c)** CONTRACTOR fails to comply with the following requirement:  
12 CONTRACTOR shall monitor the payment of the specified general  
13 prevailing rate of per diem wages by the subcontractor to the employees,  
14 by periodic review of the certified payroll records of the subcontractor;  
15 and

16           **(d)** Upon becoming aware of the failure of the subcontractor to pay his or her  
17 workers the specified prevailing rate of wages, CONTRACTOR shall  
18 diligently take corrective action to halt or rectify the failure, including, but  
19 not limited to, retaining sufficient funds due the subcontractor for work  
20 performed on the public works project; and

21           **(e)** Prior to making final payment to the subcontractor for Work performed  
22 on the Project, CONTRACTOR shall obtain an affidavit signed under  
23 penalty of perjury from the subcontractor that the subcontractor has paid  
24 the specified general prevailing rate of per diem wages to his or her  
25 employees on the Project and any amounts due pursuant to California  
26 Labor Code §1813.

27           **19.6.** Work Day and Work Week Requirements. CONTRACTOR agrees to comply with  
28 §§1810 through 1815 of the California Labor Code and, when applicable, sections 103

1 and 107 of the Contract Work Hours and Safety Standards Act, 40 U.S.C. §§3700 et seq.,  
2 as supplemented by the Department of Labor regulations, which provide that  
3 CONTRACTOR's workers and its subcontractor's workers may not be required or  
4 permitted to work more than eight (8) hours in any one (1) calendar day and forty (40)  
5 hours in any one (1) calendar week. Further, work performed by employees of  
6 CONTRACTOR or its subcontractor in excess of eight (8) hours per day, and forty (40)  
7 hours during any one (1) week, shall be compensated for all hours worked in excess of  
8 eight (8) hours per day at not less than one and one-half (1½) times the basic rate of pay.  
9 The responsibility for compliance with these provisions is fixed with CONTRACTOR.  
10 CONTRACTOR understands and agrees that it shall, as a penalty to COUNTY, forfeit  
11 specific monetary fines to COUNTY should CONTRACTOR or its subcontractors fail to  
12 comply with the provisions contained within this Paragraph.

13 **19.7. Apprenticeship Requirements.**

14 **19.7.1.** CONTRACTOR agrees to comply with §§1777.5, 1777.6 and 1777.7 of the  
15 California Labor Code relating to the employment of apprentices and to provide  
16 COUNTY with copies of any contract award information and verified statements  
17 of the journeyman and apprentice hours performed pursuant to this Agreement as  
18 required by §1777.5(e). The responsibility for compliance with these provisions  
19 is fixed with CONTRACTOR for all apprenticeable occupations, where  
20 journeymen in the craft are employed on the public work, in a ratio of not less  
21 than one (1) apprentice for each five (5) journeymen (unless an exemption is  
22 granted in accordance with §1777.5) and CONTRACTOR and its subcontractors  
23 shall not discriminate among otherwise qualified employees as indentured  
24 apprentices on any public work solely on the ground of race, religious creed, color,  
25 national origin, ancestry, sex, or age, except as provided in California Labor Code  
26 §3077. Only apprentices, as defined in California Labor Code §3077, who are in  
27 training under apprenticeship standards and who have signed written apprentice  
28 agreements will be employed on public works in apprenticeable occupations.



1 This section shall not be enforced if the not-to-exceed amount of this Agreement  
2 set forth and/or incorporated in the "COMPENSATION" Section is less than  
3 thirty thousand dollars (\$30,000).

4 **19.7.2.** If the Project falls within the jurisdiction of California Labor Code §1777.5,  
5 COUNTY shall, within five (5) days of the award, send a copy of the award to the  
6 Division of Apprenticeship Standards. In addition, COUNTY shall notify the  
7 Division of Apprenticeship Standards of a finding of any discrepancy regarding  
8 the ratio of apprentices to journeymen within five (5) days of the finding.

9 **19.8. Labor Standards Compliance Requirements.**

10 **19.8.1.** It is CONTRACTOR's responsibility to provide all labor compliance  
11 documentation from its subcontractors completely and accurately in a timely  
12 manner. CONTRACTOR is responsible to review promptly and then forward on  
13 all required documentation to COUNTY per the time schedules in the 1775  
14 Handout. Included with the Labor Compliance Handout, COUNTY will provide  
15 training, documentation requirements, forms, etc., at the preconstruction  
16 conference or at a time designated by COUNTY.

17 **19.8.2.** In the event, during the review process of labor compliance documentation from  
18 COUNTY's labor compliance monitor, inaccurate, missing or incomplete  
19 information was provided, the labor compliance monitor will request from  
20 CONTRACTOR the items, revisions and documentation needed. The cost of this  
21 additional labor compliance enforcement shall be borne by CONTRACTOR.

22 **20. INELIGIBILITY.**

23 **20.1.** CONTRACTOR represents and warrants that it and its subcontractors are not ineligible  
24 to work for COUNTY due to violations of Labor Code §§1777.1 and 1777.7.

25 **20.2.** If CONTRACTOR is deemed ineligible to perform work on public works projects  
26 pursuant to Labor Code Sections 1777.1 or 1777.7, then CONTRACTOR shall be  
27 prohibited from bidding on, being awarded an agreement for, or performing work as a  
28 subcontractor on this Project, or any other public works project within the state of

1 California.

2 **21. SIGNAGE REQUIREMENTS.**

3 **21.1. Project Identity Signage.** CONTRACTOR is required to provide and install the required  
4 project identity signage as detailed in the Plans and Specifications, in the size and at the  
5 location indicated by the Director of Public Works or his/her designee, and to maintain  
6 the signage in good condition for the duration of the Project. The signage may not be  
7 removed until the Notice of Completion is recorded or by written direction of the Director  
8 of Public Works or his/her designee.

9 **21.2. Required Employee Signage and Posters.** CONTRACTOR is required to provide and  
10 install the Federal and State required employee posters and the required material  
11 pertaining to the required labor standards provisions are posted (including, but not limited  
12 to, WH-1321, OSHA 3165 and OFCCP-English, EFCCP-Spanish) at the worksite in a  
13 prominent and accessible place.

14 **21.3. Section 3 Compliant Signage.** If required by COUNTY, CONTRACTOR is directed to  
15 provide and install the "Offer for Employment" signage as detailed in the Plans and  
16 Specifications in the size and at the location indicated by the Director of Public Works or  
17 his/her designee and to maintain the signage in good condition for the duration of the  
18 Project. The signage may not be removed until the Notice of Completion is recorded or  
19 by written direction of the Director of Public Works or his/her designee.

20 **22. CONFLICT OF INTEREST AND GRATUITIES.**

21 **22.1.** CONTRACTOR agrees that it presently has no interest and shall not acquire any interest,  
22 direct or indirect, which could conflict in any manner or degree with the performance of  
23 services required to be performed under this Agreement. CONTRACTOR further agrees  
24 that in the performance of this Agreement, no person having any such interest shall be  
25 employed.

26 **22.2.** CONTRACTOR agrees to designate such person or persons who have responsibility for  
27 carrying out the services under this Agreement and that such person or persons as may be  
28 designated shall take any and all actions necessary to comply with COUNTY's Conflict

1 of Interest Code adopted pursuant to California Government Code §81000 to the extent  
2 required thereunder.

3 **22.3.** If it is found, after notice and hearing by COUNTY, that gratuities (in the form of  
4 entertainment., gifts, or otherwise) were offered or given by CONTRACTOR, or any  
5 agent or representative of CONTRACTOR, to any officer, employee or agent of  
6 COUNTY with a view toward securing a contract or securing favorable treatment with  
7 respect to the awarding or amending or the making of any determinations with respect to  
8 the performance of this Agreement, COUNTY may, by written notice to  
9 CONTRACTOR, terminate the right of CONTRACTOR to proceed under this  
10 Agreement and/or may pursue such other rights and remedies provided by law or under  
11 this Agreement.

12 **22.4.** In the event this Agreement is terminated as provided herein, COUNTY shall be entitled  
13 to:

14 **22.4.1.** Pursue the same remedies against CONTRACTOR as it could pursue in the event  
15 of a breach of the Agreement by CONTRACTOR; and

16 **22.4.2.** As a penalty in addition to any other damages to which it may be entitled by law,  
17 to exemplary damages in an amount (as determined by COUNTY) which shall be  
18 not less than three (3) nor more than ten (10) times the costs incurred by  
19 CONTRACTOR in providing any such gratuities to any such officer, employee  
20 or agent.

21 **23. HOUSING AND URBAN DEVELOPMENT ACT COMPLIANCE.**

22 When applicable, CONTRACTOR agrees to comply with Section 3 of the Housing and Urban  
23 Development Act of 1968 (42 U.S.C. 3601 et seq.) which provides that to the greatest extent feasible,  
24 CONTRACTOR shall provide job training, employment and contracting opportunities for low- or very-  
25 low income residents in connection with the Project. The responsibility for compliance with these  
26 provisions is fixed with CONTRACTOR.

27 **24. COPELAND "ANTI-KICKBACK" ACT COMPLIANCE.**

28 When applicable, CONTRACTOR agrees to comply with the Copeland Act

1 (18 USC §874 and 40 USC §276c; 29 C.F.R. Part 3) which precludes CONTRACTOR and its  
2 subcontractors from in any way inducing an employee to give up any part of the compensation to which  
3 he or she is entitled under his or her contract of employment. CONTRACTOR and its subcontractors  
4 shall submit a weekly statement of the wages paid to each employee performing on covered work during  
5 the preceding payroll period. CONTRACTOR understands and agrees that should CONTRACTOR its  
6 subcontractors induce an employee working on a covered contract to give up any part of the  
7 compensation to which he or she is entitled, the inducing party may be subject to a five thousand dollar  
8 (\$5,000) fine, or imprisonment for up to five (5) years, or both. CONTRACTOR also understands and  
9 agrees that willful falsification of the statement of compliance may subject the employer to civil or  
10 criminal prosecution and may be cause for contract termination or debarment. The responsibility for  
11 compliance with these provisions is fixed with CONTRACTOR.

12 **25. FAIR LABOR STANDARDS ACT COMPLIANCE.**

13 When applicable, CONTRACTOR agrees to comply with the Fair Labor Standards Act of 1938  
14 as amended (29 U.S.C. 201 et seq.) which establishes minimum wage, overtime pay, recordkeeping, and  
15 youth employment standards affecting full-time and part-time workers on the Project. The responsibility  
16 for compliance with these provisions is fixed with CONTRACTOR.

17 **26. CERTIFICATION REGARDING DEBARMENT, SUSPENSION AND OTHER**  
18 **RESPONSIBILITY MATTERS.**

19 When applicable, CONTRACTOR agrees to execute a certification regarding debarment,  
20 suspension and other responsibility matters. The responsibility for compliance with this provision is  
21 fixed with CONTRACTOR.

22 **27. FEDERAL EQUAL EMPLOYMENT OPPORTUNITY CONSTRUCTION CONTRACT**  
23 **SPECIFICATIONS.**

24 When applicable, CONTRACTOR agrees to incorporate the notice set forth in paragraph (d) of  
25 41 C.F.R. 60-4.2 relating to the “Equal Opportunity Clause” and the “Standard Federal Equal  
26 Employment Specifications.” The responsibility for compliance with this provision is fixed with  
27 CONTRACTOR.

28 **28. CLEAN AIR ACT AND THE FEDERAL WATER POLLUTION CONTROL ACT.**

1 When applicable, CONTRACTOR agrees to comply with all applicable standards, orders or  
2 regulations issued pursuant to the Clean Air Act (42 U.S.C. 7401 et seq.), the Federal Water Pollution  
3 Control Act as amended (33 U.S.C. 1251 et seq.), Presidential Executive Order 11738 and  
4 Environmental Protection Agency regulations set forth at 40 C.F.R. Part 15. CONTRACTOR  
5 understands and agrees that violations shall be reported to the Federal awarding agency and the Regional  
6 Office of the Environmental Protection Agency. The responsibility for compliance with these provisions  
7 is fixed with CONTRACTOR.

8 **29. PROHIBITION ON THE USE OF FEDERAL FUNDS FOR LOBBYING.**

9 When applicable, CONTRACTOR shall file the required certification. Each tier certifies to the  
10 tier above that it will not and has not used Federal appropriated funds to pay any person or organization  
11 for influencing or attempting to influence an officer or employee of any agency, a member of Congress,  
12 officer or employee of Congress, or an employee of a member of Congress in connection with obtaining  
13 any Federal contract, grant or any other award covered by 31 U.S.C. 1352. Each tier shall also disclose  
14 any lobbying with non-Federal funds that takes place in connection with obtaining any Federal award.  
15 Such disclosures are forwarded from tier to tier up to the recipient. The responsibility for compliance  
16 with this provision is fixed with CONTRACTOR.

17 **30. FEDERAL EMPLOYMENT ELIGIBILITY VERIFICATION.**

18 CONTRACTOR shall verify name, date of birth and social security number, along with  
19 immigration information for non-citizens in order to verify the identity and employment eligibility of  
20 both citizen and non-citizen new hires. The responsibility for compliance with this provision is fixed  
21 with CONTRACTOR.

22 **31. THE CIVIL RIGHTS, HCD AND AGE DISCRIMINATION ACT ASSURANCES.**

23 **31.1.** During the performance of this Agreement, CONTRACTOR assures that no otherwise  
24 qualified person shall be excluded from participation or employment, denied program  
25 benefits or be subjected to discrimination based on race, color, national origin, gender,  
26 age or handicap, under any program or activity funded by this Agreement, as required by  
27 Title VI of the Civil Rights Act of 1964, Title I of the Housing and Community  
28 Development Act of 1974, as amended, and the Age Discrimination Act of 1975, and all

1 implementing regulations. The responsibility for compliance with these provisions is  
2 fixed with CONTRACTOR.

3 **31.2.** CONTRACTOR and its subcontractors shall not discriminate on the basis of race, color,  
4 national origin, or sex in the performance of this Agreement. CONTRACTOR shall carry  
5 out the applicable requirements of 49 C.F.R. Chapter 26 in the award and administration  
6 of Department of Transportation assisted contracts. Failure by CONTRACTOR to carry  
7 out these requirements is a material breach of this Agreement, which may result in the  
8 termination of this Agreement, or such other remedy as COUNTY deems appropriate.  
9 CONTRACTOR shall include the nondiscrimination and compliance provisions of this  
10 Paragraph in all subcontracts to perform Work under this Agreement.

11 **32. FEDERAL EQUAL EMPLOYMENT OPPORTUNITY REQUIREMENTS.**

12 **32.1.** CONTRACTOR hereby agrees that it will incorporate or cause to be incorporated into  
13 any contract for construction work, or modification thereof, as defined in the regulations  
14 of the Secretary of Labor at 41 C.F.R. Chapter 60, which is paid for in whole or in part  
15 with funds obtained from the Federal Government or borrowed on the credit of the  
16 Federal Government pursuant to a grant, contract, loan insurance, or guarantee, or  
17 undertaken pursuant to any Federal program involving such grant, contract, loan,  
18 insurance, or guarantee, the following equal opportunity clause. For the purposes of this  
19 Subsection, the term “contractor” shall refer to CONTRACTOR, and the term “contract”  
20 shall refer to this Agreement:

21 *“During the performance of this contract, the Contractor agrees as follows:*

22 *(1) The contractor will not discriminate against any employee or applicant for*  
23 *employment because of race, color, religion, sex, or national origin. The contractor*  
24 *will take affirmative action to ensure that applicants are employed, and that*  
25 *employees are treated during employment, without regard to their race, color,*  
26 *religion, sex, or national origin. Such action shall include, but not be limited to the*  
27 *following: Employment, upgrading, demotion, or transfer, recruitment or recruitment*  
28 *advertising; layoff or termination; rates of pay or other forms of compensation; and*

1                    *selection for training, including apprenticeship. The contractor agrees to post in*  
2                    *conspicuous places, available to employees and applicants for employment, notices*  
3                    *to be provided by the contracting officer setting forth the provisions of this*  
4                    *nondiscrimination clause.*

5                    *(2) The contractor will, in all solicitations or advertisements for employees placed by or*  
6                    *on behalf of the contractor, state that all qualified applicants will receive*  
7                    *consideration for employment without regard to race, color, religion, sex, or national*  
8                    *origin.*

9                    *(3) The contractor will send to each labor union or representative of workers with which*  
10                    *he has a collective bargaining agreement or other contract or understanding, a notice*  
11                    *to be provided by the agency contracting officer, advising the labor union or workers'*  
12                    *representative of the contractor's commitments under section 202 of Executive Order*  
13                    *11246 of September 24, 1965, and shall post copies of the notice in conspicuous*  
14                    *places available to employees and applicants for employment.*

15                    *(4) The contractor will comply with all provisions of Executive Order 11246 of*  
16                    *September 24, 1965, and of the rules, regulations, and relevant orders of the*  
17                    *Secretary of Labor.*

18                    *(5) The contractor will furnish all information and reports required by Executive Order*  
19                    *11246 of September 24, 1965, and by the rules, regulations, and orders of the*  
20                    *Secretary of Labor, or pursuant thereto, and will permit access to his books, records,*  
21                    *and accounts by the contracting agency and the Secretary of Labor for purposes of*  
22                    *investigation to ascertain compliance with such rules, regulations, and orders.*

23                    *(6) In the event of the contractor's non-compliance with the nondiscrimination clauses of*  
24                    *this contract or with any of such rules, regulations, or orders, this contract may be*  
25                    *canceled, terminated or suspended in whole or in part and the contractor may be*  
26                    *declared ineligible for further Government contracts in accordance with procedures*  
27                    *authorized in Executive Order 11246 of September 24, 1965, and such other sanctions*  
28                    *may be imposed and remedies invoked as provided in Executive Order 11246 of*

1                   September 24, 1965, or by rule, regulation, or order of the Secretary of Labor, or as  
2                   otherwise provided by law.

3                   (7) the contractor will include the provisions of paragraphs (1) through (7) in every  
4                   subcontract or purchase order unless exempted by rules, regulations, or orders of the  
5                   Secretary of Labor issued pursuant to section 204 of Executive Order 11246 of  
6                   September 24, 1965, so that such provisions will be binding upon each subcontractor  
7                   or vendor. The contractor will take such action with respect to any subcontract or  
8                   purchase order as may be directed by the Secretary of Labor as a means of enforcing  
9                   such provisions including sanctions for noncompliance: Provided, however, that in  
10                  the event the contractor becomes involved in, or is threatened with, litigation with a  
11                  subcontractor or vendor as a result of such direction, the contractor may request the  
12                  United States to enter into such litigation to protect the interests of the United States.”

13                  **32.2.** CONTRACTOR further agrees that it will be bound by the above equal opportunity  
14                  clause with respect to its own employment practices when it participates in federally-  
15                  assisted construction work; provided that if CONTRACTOR so participating is a State or  
16                  local government, the above equal opportunity clause is not applicable to any agency,  
17                  instrumentality, or subdivision of such government which does not participate in work on  
18                  or under the Agreement.

19                  **32.3.** CONTRACTOR agrees that it will assist and cooperate actively with the administering  
20                  agency and the Secretary of Labor in obtaining the compliance of Contractors and  
21                  subcontractors with the equal opportunity clause and the rules, regulations, and relevant  
22                  orders of the Secretary of Labor, that it will furnish the Department and HUD and the  
23                  Secretary of Labor such information as they may require for the supervision of such  
24                  compliance, and that it will otherwise assist the administering agency in the discharge of  
25                  the agency’s primary responsibility for securing compliance.

26                  **32.4.** CONTRACTOR further agrees that it will refrain from entering into any contract or  
27                  contract modification subject to Executive Order 11246 of September 24, 1965, with a  
28                  contractor debarred from, or who has not demonstrated eligibility for, government



1 contracts and federally-assisted construction contracts, pursuant to the Executive Order  
2 and will carry out such sanctions and penalties for violation of the equal opportunity  
3 clause as may be imposed upon contractors and subcontractors by the administering  
4 agency or the Secretary of Labor pursuant to Part II, Subpart D of the Executive Order.  
5 In addition, CONTRACTOR agrees that if it fails or refuses to comply with these  
6 undertakings, COUNTY may take any or all of the following actions: Cancel, terminate,  
7 or suspend in whole or in part this funding commitment (contract, loan, grant, insurance,  
8 guarantee); refrain from extending any further assistance to the applicant under the  
9 program with respect to which the failure or refund occurred until satisfactory assurance  
10 of future compliance has been received from such Contractor; and refer the case to the  
11 Department of Justice for appropriate legal proceedings.

12 **33. ASSIGNMENT OF CLAIMS – CLAYTON OR CARTWRIGHT ACTS.**

13 CONTRACTOR shall comply with the following provisions regarding the assignment of claims arising  
14 from either the Clayton Act or the Cartwright. For the purposes of this Section, the term “contractor”  
15 shall refer to CONTRACTOR, the term “awarding body” shall refer to COUNTY, and the term “public  
16 works contract” shall refer to this Agreement:

17 *“In entering into a public works contract or a subcontract to supply goods, services, or materials*  
18 *pursuant to a public works contract, the contractor or subcontractor offers and agrees to assign to the*  
19 *awarding body all rights, title, and interest in and to all causes of action it may have under Section 4 of*  
20 *the Clayton Act (15 U.S.C. Sec. 15) or under the Cartwright Act (Chapter 2 (commencing with Section*  
21 *16700) of Part 2 of Division 7 of the Business and Professions Code), arising from purchases of goods,*  
22 *services, or materials pursuant to the public works contract or the subcontract. This assignment shall*  
23 *be made and become effective at the time the awarding body tenders final payment to the contractor,*  
24 *without further acknowledgment by the parties.”*

25 **34. NON-COLLUSION.**

26 CONTRACTOR agrees he/she has executed and submitted with the Bid a Non-Collusion Affidavit that  
27 complies with Cal. Public Code §7106, included in **Exhibit “B”** and incorporated herein.

28 **35. NOTICES AND REPORTS.**



1 CONTRACTOR without the prior written consent of COUNTY.

2 **38. MODIFICATION.**

3 No modification, waiver, amendment, discharge, or change of this Agreement shall be valid  
4 unless the same is in writing and signed by the Party against whom the enforcement of such modification,  
5 waiver, amendment, discharge, or change is or may be sought.

6 **39. CAPTIONS.**

7 Captions in this Agreement are inserted for convenience of reference only and do not define,  
8 describe or limit the scope or the intent of this Agreement or any of the terms thereof.

9 **40. PARTIAL INVALIDITY.**

10 If any provision in this Agreement is held by a court of competent jurisdiction to be invalid, void,  
11 or unenforceable, the remaining provisions will nevertheless continue in full force without being  
12 impaired or invalidated in any way.

13 **41. GENDER AND INTERPRETATION OF TERMS AND PROVISIONS.**

14 Words and expressions in the masculine gender include the feminine and neuter genders. Words  
15 and expressions in the singular include the plural and words and expressions in the plural include the  
16 singular. CONTRACTOR as used in this Agreement or in any other document referred to in or made a  
17 part of this Agreement shall likewise include both singular and the plural, a corporation, a partnership,  
18 individual, firm or person acting in any fiduciary capacity as executor, administrator, trustee or in any  
19 other representative capacity or any other entity. All covenants herein contained on the part of  
20 CONTRACTOR shall be joint and several if more than one person, firm or entity executes the  
21 Agreement.

22 **42. WAIVER.**

23 No waiver of any breach or of any of the covenants or conditions of this Agreement shall be  
24 construed to be a waiver of any other breach or to be consent to any further or succeeding breach of the  
25 same or any other covenant or condition.

26 **43. CHOICE OF LAW.**

27 The laws of the State of California shall govern this Agreement. This Agreement is made and  
28 entered into in Imperial County, California. Any action brought by either Party with respect to this

1 Agreement shall be brought in a court of competent jurisdiction within said County.

2 **44. AUTHORITY.**

3 **44.1.** Each individual executing this Agreement on behalf of CONTRACTOR represents and  
4 warrants that:

5 **44.1.1.** He/She is duly authorized to execute and deliver this Agreement on behalf of  
6 CONTRACTOR;

7 **44.1.2.** Such execution and delivery is in accordance with the terms of the Articles of  
8 Incorporation or Partnership, any by-laws or Resolutions of CONTRACTOR and;

9 **44.1.3.** This Agreement is binding upon CONTRACTOR in accordance with its terms.

10 **44.2.** CONTRACTOR shall deliver to COUNTY evidence acceptable to COUNTY of the  
11 foregoing within thirty days of execution of this Agreement.

12 **45. COUNTERPARTS.**

13 This Agreement and any subsequent modifications may be executed in any number of  
14 counterparts, each of which when executed shall be an original, and all of which together shall constitute  
15 one and the same Agreement. No counterparts shall be effective until all Parties have executed a  
16 counterpart hereof.

17 **46. TIMING.**

18 The Parties agree that time is of the essence in this Agreement.

19 **47. REVIEW OF AGREEMENT TERMS.**

20 **47.1.** Each Party has had the opportunity to receive independent legal advice from its attorneys  
21 with respect to the advisability of making the representations, warranties, covenants and  
22 agreements provided for herein, and with respect to the advisability of executing this  
23 Agreement.

24 **47.2.** Each Party represents and warrants to and covenants with the other Party that:

25 **47.2.1.** This Agreement in its reduction to final written form is a result of extensive good  
26 faith negotiations between the Parties and/or their respective legal counsel; and

27 **47.2.2.** The Parties and/or their legal counsel have carefully reviewed and examined this  
28 Agreement for execution by said Parties.



1 systems, places of public accommodation, and certain testing entities (42 U.S.C. §§  
2 12131-12189) as implemented by Department of Transportation regulations at 49 C.F.R.  
3 parts 37 and 38;

4 (i) The Federal Aviation Administration's Nondiscrimination statute (49 U.S.C. § 47123)  
5 (prohibits discrimination on the basis of race, color, national origin, and sex);

6 (j) Executive Order 12898, Federal Actions to Address Environmental Justice in Minority  
7 Populations and Low-Income Populations, which ensures discrimination against minority  
8 populations by discouraging programs, policies, and activities with disproportionately  
9 high and adverse human health or environmental effects on minority and low-income  
10 populations;

11 (k) Executive Order 13166, Improving Access to Services for persons with Limited English  
12 Proficiency, and resulting agency guidance, national origin discrimination includes  
13 discrimination because of limited English proficiency (LEP). To ensure compliance with  
14 Title VI, you must take reasonable steps to ensure that LEP persons have meaningful  
15 access to your programs (70 Fed. Reg. at 74087 to 74100);

16 (l) Title IX of the Education Amendment of 1972, as amended, which prohibits you from  
17 discriminating because of sex in education programs or activities (20 U.S.C. 1681 et seq).

18 **IN WITNESS WHEREOF**, the Parties have executed this Agreement on the day and year first  
19 above written.

20  
21 **County of Imperial**

21 **«Contractor\_Business\_Name»**

22  
23  
24 By: \_\_\_\_\_  
25 Jesus Eduardo Escobar, Chairman  
26 Imperial County Board of Supervisors

24 By: \_\_\_\_\_  
25 «Contractor\_Name\_for\_Signature»

26  
27 **ATTEST:**

28 By: \_\_\_\_\_

1 Blanca Acosta,  
2 Clerk of the Board of Supervisors

3 **APPROVED AS TO FORM:**

4 Eric Havens,  
5 County Counsel

6  
7 By: \_\_\_\_\_  
8 «CC\_Attorney»,  
9 «CC\_Attorney\_Title»

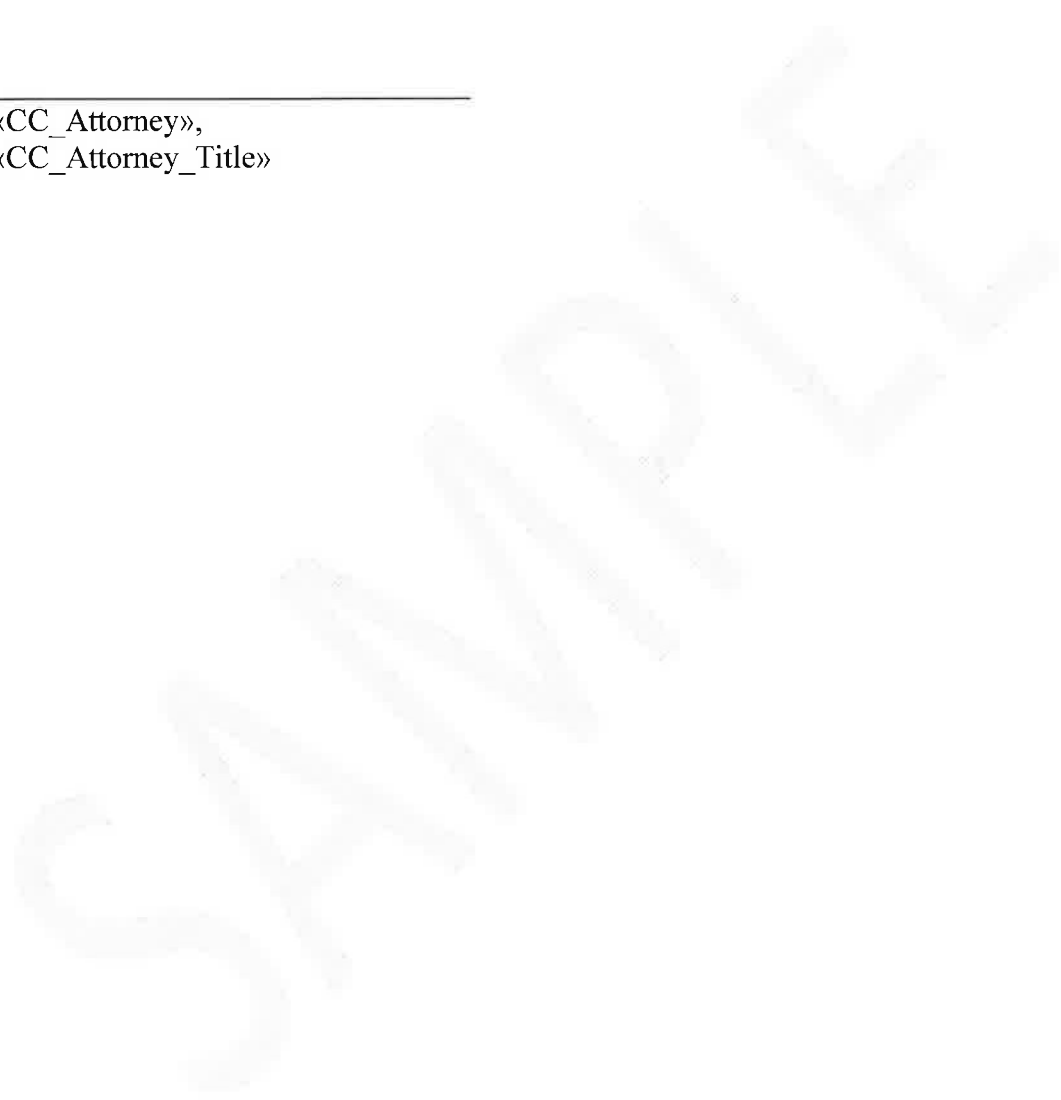

10  
11  
12  
13  
14  
15  
16  
17  
18  
19  
20  
21  
22  
23  
24  
25  
26  
27  
28

