

County of Imperial
Department of Public Works

PROJECT MANUAL

SUNBEAM LAKE WADING AREA IMPROVEMENTS
LOCATED AT 1750 DREW ROAD, EL CENTRO, CA 92243

COUNTY PROJECT NO. 6579PKS



Requested by:
John A. Gay, P.E.
Director of Public Works

Department of Public Works
155 South 11th Street
El Centro, CA 92243
Phone: (442) 265-1818
Fax: (442) 265-1858



Contact Person(s): Jenell Guerrero, MPA – Administrative Analyst III
jenellguerrero@co.imperial.ca.us

Bid Opening: Friday, December 18, 2020 @ 2:00 P.M.

SPECIAL NOTICE

Pursuant to the requirements of Senate Bill 854 and California Labor Code section 1725.5, all contractors and subcontractors that wish to engage in public work through a public works contract must first register with the Department of Industrial Relation and pay all applicable fees.

Beginning March 1, 2015, no contractor or subcontractor may be listed on a bid proposal for a public works project unless registered with the Department of Industrial Relations, pursuant to Labor Code section 1725.5 (with limited exceptions from this requirement for bid purposes only under Labor Code section 1771.1(a)).

Beginning April 1, 2015, no contractor or subcontractor may be awarded a contract for public work on a public works project unless registered with the Department of Industrial Relations, pursuant to Labor Code section 1725.5.

This Project is subject to compliance monitoring and enforcement by the Department of Industrial Relations.

For more information concerning Senate Bill 854 compliance, please visit: <http://www.dir.ca.gov/Public-Works/SB854.html>.

PUBLIC WORKS REFORMS (SB 854) FACT SHEET

Public works reforms (SB 854) were signed into law on June 20, 2014. The reforms made several significant changes to the administration and enforcement of prevailing wage requirements by the Department of Industrial Relations (DIR). Among other things, SB 854 established a public works contractor registration program to replace prior Compliance Monitoring Unit (CMU) and Labor Compliance Program (LCP) requirements for bond-funded and other specified public works projects. The fees collected through the program established by SB 854 are used to fund DIR's public works activities.

Essentials of public works contractor registration program:

- Contractors are subject to a registration and annual renewal fee set at \$400. This fee is non-refundable and applies to all contractors and subcontractors who intend to bid or perform work on public works projects (as defined under the Labor Code).
- Contractors apply and pay the fee online and must meet minimum qualifications to be registered as eligible to bid and work on public works projects:
 - Must have workers' compensation coverage for any employees and only use subcontractors who are registered public works contractors.
 - Must have Contractors State License Board license if applicable to trade.
 - Must not have any delinquent unpaid wage or penalty assessments owed to any employee or enforcement agency.
 - Must not be under federal or state debarment.
 - Must not be in prior violation of this registration requirement once it becomes effective. However, for the first violation in a 12-month period, a contractor may still qualify for registration by paying an additional penalty.
- The registration fee is not related to any project. It is more like a license that enables the registrant to bid on and perform public works.
- DIR provides a searchable database of registered contractors and subcontractors on its website, so that awarding bodies and contractors can comply with the requirement to only use registered contractors and subcontractors.
- Various protections are built in so that
 - A contractor won't be in violation for working on a private job that is later determined to be public work;
 - The inadvertent listing of an unregistered subcontractor on a bid doesn't necessarily invalidate that bid;
 - A contract with an unregistered contractor or subcontractor is subject to cancellation but is not void as to past work;
 - An unregistered contractor or subcontractor can be replaced with one who is registered;
 - A contractor whose registration lapses will have a 90-day grace period within which to pay a late fee and renew.
- Contractors and subcontractors register online. The preferred method of payment is by credit card.
- The requirement to list only registered contractors and subcontractors on bids became effective on March 1, 2015. The requirement to only use registered contractors and subcontractors on public works projects applies to all projects awarded on or after April 1, 2015.

Essentials of Public Works Enforcement Fund:

All contractor registration fees go into the State Public Works Enforcement Fund and are used to fund the following items:

- Administration of contractor registration requirement;
- All DIR costs for administering and enforcing public works laws;

- Labor Commissioner's enforcement of other Labor Code violations on monitored public works projects.

DIR no longer charges awarding bodies for prevailing wage compliance monitoring and enforcement on legacy CMU projects.

Related changes in DIR's administration and enforcement of public works requirements:

- Requirements to use CMU or specified alternative (labor compliance program or project labor agreement) for state bond-funded and other specified projects were eliminated and replaced by requirements that apply to *all* public works projects (as defined under the Labor Code).
- Awarding bodies are required to submit PWC-100 (contract award notice) for all public works projects.
- Contractors and subcontractors on *all* public works projects are required to submit certified payroll records (CPRs) to the Labor Commissioner unless excused from this requirement.
 - CPRs are furnished to the Labor Commissioner online
 - This requirement phases in as follows:
 - Applied to public works projects that had been under CMU monitoring;
 - Applies to any new projects awarded on or after April 1, 2015;
 - May apply to other projects as determined by Labor Commissioner;
 - Applies to *all* public works projects, (except those listed under Exemptions just below), on and after January 1, 2016.
 - **Exemptions:** As of April 1, 2015, and even after January 1, 2016, the following projects are exempt from the requirement to have contractors and subcontractors furnish certified payroll records (CPRs) to the Labor Commissioner:

Small Project Exemption

Contractors who work exclusively on small public works projects are not required to register as a public works contractor or file electronic certified payroll reports for those projects. Contractors are still required to maintain certified payroll records on a continuous basis, and provide them to the Labor Commissioner's Office upon request. Additionally, awarding agencies are not required to submit the notice of contract award through DIR's PWC-100 system on projects that fall within the small project exemption. The small project exemption applies for all public works projects that do not exceed:

- \$25,000 for new construction, alteration, installation, demolition or repair
- \$15,000 for maintenance

Any projects monitored and enforced by the following legacy LCPs:

- California Department of Transportation (Caltrans)
- City of Los Angeles
- Los Angeles Unified School District
- County of Sacramento

Projects covered by qualifying project labor agreements, at the Labor Commissioner's discretion.

- Requirements for awarding bodies to adopt and enforce a DIR-approved LCP are now limited to: (1) ongoing public works projects awarded prior to January 1, 2012, that were under a pre-existing LCP requirement (see the four legacy LCPs listed above) and (2) projects funded in whole or in part by Proposition 84.

June 2017

**SUNBEAM LAKE WADING AREA IMPROVEMENTS
LOCATED AT 1750 DREW ROAD, EL CENTRO, CA 92243**

COUNTY PROJECT NO. 6579PKS

TABLE OF CONTENTS

| | |
|---|----|
| Notice to Contractor Calling for Bids | 7 |
| Information for Bidders | 12 |
| Bid Form | 16 |
| Non-collusion Affidavit to be Executed by Bidder and Submitted with Bid | 19 |
| Designation of Subcontractors | 20 |
| Public Contract Code Section 10162 Questionnaire | 22 |
| Contractor's Certificate Regarding Workers Compensation | 23 |
| Bid Bond | 24 |
| Performance Bond | 26 |
| Payment Bond for Public Works | 27 |
| Contents of General Conditions | 28 |
| General Conditions | 30 |
| Exhibit A – Plans and Specifications | |
| Exhibit B – Sample Agreement | |

NOTICE TO CONTRACTOR CALLING FOR BIDS

NOTICE IS HEREBY GIVEN that the COUNTY OF IMPERIAL, California, acting by and through its Board of Supervisors (hereinafter referred to as "COUNTY"), will receive up to, but not later than **2:00p.m. on December 18, 2020**, sealed bids for the award of a contract for the proposed project:

SUNBEAM LAKE WADING AREA IMPROVEMENTS LOCATED AT 1750 DREW ROAD, EL CENTRO, CA 92243

COUNTY PROJECT NO. 6579PKS

The Contractor shall possess a California Contractors B License, at the time this contract is awarded. Bids shall be received in the office of the Clerk of the Board of Supervisors, 940 Main Street, Suite 209, El Centro, California 92243, and shall be opened publicly and read aloud at the above stated time and place.

Each bid package must conform and be responsive to the contract documents, bid sets are available starting on **Wednesday, November 18, 2020** at the following <https://publicworks.imperialcounty.org/> "Projects out to bid" at no charge and at Public Works, 155 South 11TH Street, El Centro, CA, 92243, Phone (442) 265-1818, Monday through Thursday 8:00 AM - 5:00 PM (PDT) for a hard copy set for a fee. Those desiring to pick up bid sets shall call to reserve a copy of bid documents to ensure the availability.

A one hundred dollar (\$100) non-refundable fee for each hardcopy bid package set of the contract documents is required.

Only those firms who have purchased the bid documents will be mailed any addendums that may be issued for this project prior to the bid opening date. *Otherwise, it is the responsibility of the potential bidder to check the Imperial County Public Works website for project updates and applicable documentation.*

Each bid shall be accompanied by the bid security referred to in the contract documents and the list of proposed subcontractors in the form of a certified or cashier check or a bid bond for ten percent (10%) of the maximum bid amount being proposed.

In contracts involving expenditure in excess of ten thousand dollars (\$10,000), the successful bidder shall file a payment bond in a penal sum at least equal to the full contract value as awarded. The bond shall be approved by COUNTY and shall be in the form set forth in the contract documents. The successful bidder shall also file a performance bond in a penal sum at least equal to the full contract value as awarded.

A performance and payment bond must be filed for contracts involving expenditure in excess of twenty-five thousand dollars (\$25,000), and may be required for contracts involving smaller expenditures at the option of COUNTY.

A Contractor's and Subcontractor's Pre-Bid Conference will be held on the following date: **Tuesday, December 8, 2020 at 10:00 a.m.** at:

**SUNBEAM LAKE WADING AREA IMPROVEMENTS
LOCATED AT 1750 DREW ROAD, EL CENTRO, CA 92243
Contact Person(s): Jenell Guerrero, MPA – Administrative Analyst III
Telephone: (442) 265-1818 or jenellguerrero@co.imperial.ca.us**

Attendance at the Pre-Bid facility walkthrough is **MANDATORY**. *Any firm that does not attend the mandatory site visit/briefing shall not be eligible to submit a bid proposal.*

Before submitting a bid, ALL BIDDERS are required to examine the project site and fully inform themselves as to all existing site conditions and limitations. The bid proposal shall include the cost of all items necessary for the construction of the Project. Bidder shall not receive any additional compensation for costs resulting from conditions that Bidder could have discovered with due diligence prior to submitting a bid.

Any potential bidder whom has been deemed ineligible to perform work on public works projects pursuant to Labor Code Sections 1777.1 or 1777.7 shall be prohibited from bidding on, being awarded a contract for, or performing work as a subcontractor on this project, or any other public works project within the state of California.

COUNTY reserves the right to reject any or all bids or to waive any irregularities or informalities in any bids or in the bidding.

All information required by the bid forms must be completely and accurately provided. Numbers shall be stated in both words and figures where so indicated in the bid forms; conflicts between a number stated in words and in figures are governed by the words. Partially completed Bid Proposals, including bid forms with items left blank, or Bid Proposals submitted on other than the bid forms included herein are non-responsive and will be rejected. Bid Proposals not conforming to these instructions for bidders and the Notice to Contractors Calling for Bids may be deemed nonresponsive and rejected.

Pursuant to Section 20103.8 of the Public Contract Code: A local agency may require a bid for a public works contract to include prices for items that may be added to, or deducted from, the scope of work in the contract for which the bid is being submitted. Whenever additive or deductive items are included in a bid, the bid solicitation shall specify which one of the following methods will be used to determine the lowest bid. In the absence of a specification, only the method provided by subdivision (a) will be used:

A responsible bidder who submitted the lowest bid as determined by this section shall be awarded the contract, if it is awarded. This section does not preclude the local agency from adding to or deducting from the contract any of the additive or deductive items after the lowest responsible bidder has been determined.

**ENGINEER’S OPINION OF PROBABLE QUANTITY
BASE BID**

| ITEM # | ITEM DESCRIPTION | UNIT | ESTIMATED QUANTITY | UNIT PRICE | TOTAL |
|--------|--|------|--------------------|------------|-------|
| 1 | Mobilization/ Demobilization, Temporary Facilities, Construction Sign, Insurance, Bonds, Taxes, Permits, Fees and Similar Expenses | LS | 1 | | |
| 2 | Cut New Spillway-Existing Curb | LS | 1 | | |
| 3 | Sprinkler Lines | LF | 200 | | |
| 4 | Remove & Replant Trees | EA | 1 | | |
| 5 | Clear & Grub Cove for earth fill | LS | 1 | | |
| 6 | Excavation | CY | 1,125 | | |

| | | | | | |
|----|--------------------------------------|----|--------|--|--|
| 7 | Fine grade | SF | 10,125 | | |
| 8 | Trench for Liner Anchor | LF | 606 | | |
| 9 | RPE Liner | SF | 10,125 | | |
| 10 | HDPE Batten Anchor | LF | 17 | | |
| 11 | Sand Cover | CY | 375 | | |
| 12 | Fine Grade | SF | 10,125 | | |
| 13 | Perimeter Walk Path | SF | 2,000 | | |
| 14 | 4" SDR35PVC | LF | 160 | | |
| 15 | Spillway to Lake | LS | 1 | | |
| 16 | Grated inlet and drain | EA | 2 | | |
| 17 | 4" dia. Gate valve and riser w/cover | EA | 1 | | |
| 18 | New Chlorinator | LS | 1 | | |

Nothing in this section shall preclude the prequalification of subcontractors.

COUNTY hereby affirms and notifies all bidders that it will affirmatively ensure that in any contract entered into pursuant to this advertisement, disadvantaged business enterprises will be afforded full opportunity to submit bids in response to this invitation and will not be discriminated on the grounds of race, sex, color, or national origin in consideration for an award.

Pursuant to section 1773 of the Labor Code, the general prevailing rate of wages in the County in which the work is to be done has been determined by the Director of the California Department of Industrial Relations and are on file and available from the Clerk of the Board of Supervisors located at the County Administration Center, 940 Main Street, El Centro, CA 92243.

The Director of Industrial Relations has determined the general prevailing rate of per diem wages in the locality in which this work is to be performed for each craft or type of worker needed to execute the contract which will be awarded to the successful bidder.

Use the following internet access URL:

<http://www.dir.ca.gov/dlsr/PWD/>

It shall be mandatory upon the Contractor to whom the contract is awarded, and upon any subcontractor under it, to pay not less than the said specified rates to all workers employed by them in the execution of the contract. No bidder may withdraw their bid for a period of ninety (90) days after the date set for the opening of bids.

Bidders are advised that they may elect to substitute securities for any retention of funds by the County to ensure performance under the Contract. At the request and expense of Bidder, securities equivalent to the amount retained shall be deposited with the County, or with a state or federally chartered bank in this state as the escrow agent, who shall then return the securities to Bidder once the Project has been completed.

Alternatively, the Bidder may request, and the County shall make payment of retentions earned directly to the escrow agent at the expense of the Bidder. The Bidder, at its sole cost and expense, may direct the investment of the payments into securities, and the Bidder shall receive the interest earned on the investments. Once the Project has been completed, the Bidder shall receive from the escrow agent all securities, interest and payments received by the escrow agent from the County.

Securities eligible for investment include those listed in Cal Gov Code § 16430, bank or savings and loan certificates of deposit, interest-bearing demand deposit accounts, standby letters of credit, or any other security mutually agreed to by the County and the Bidder. The Bidder shall be the beneficial owner of any securities substituted for retained funds and shall receive any interest thereon.

Substitution of securities shall be conducted through an Escrow Agreement substantially similar to that found in Cal Pub Contract Code § 22300(f).

PLEASE NOTE: Substitution of securities is prohibited where funding for the Project, in whole or in part, will be provided by the Farmers Home Administration of the United States Department of Agriculture pursuant to the Consolidated Farm and Rural Development Act (7 U.S.C. Sec 1921 et seq.) or where otherwise disallowed by federal law.

 11-18-20
Blanca Acosta Date
Clerk of the Board of Supervisors

Approved for Construction

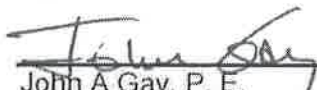
 11/18/20
John A. Gay, P. E. Date
Director of Public Works

PROJECT LOCATION
1750 Drew Road, El Centro, CA 92243

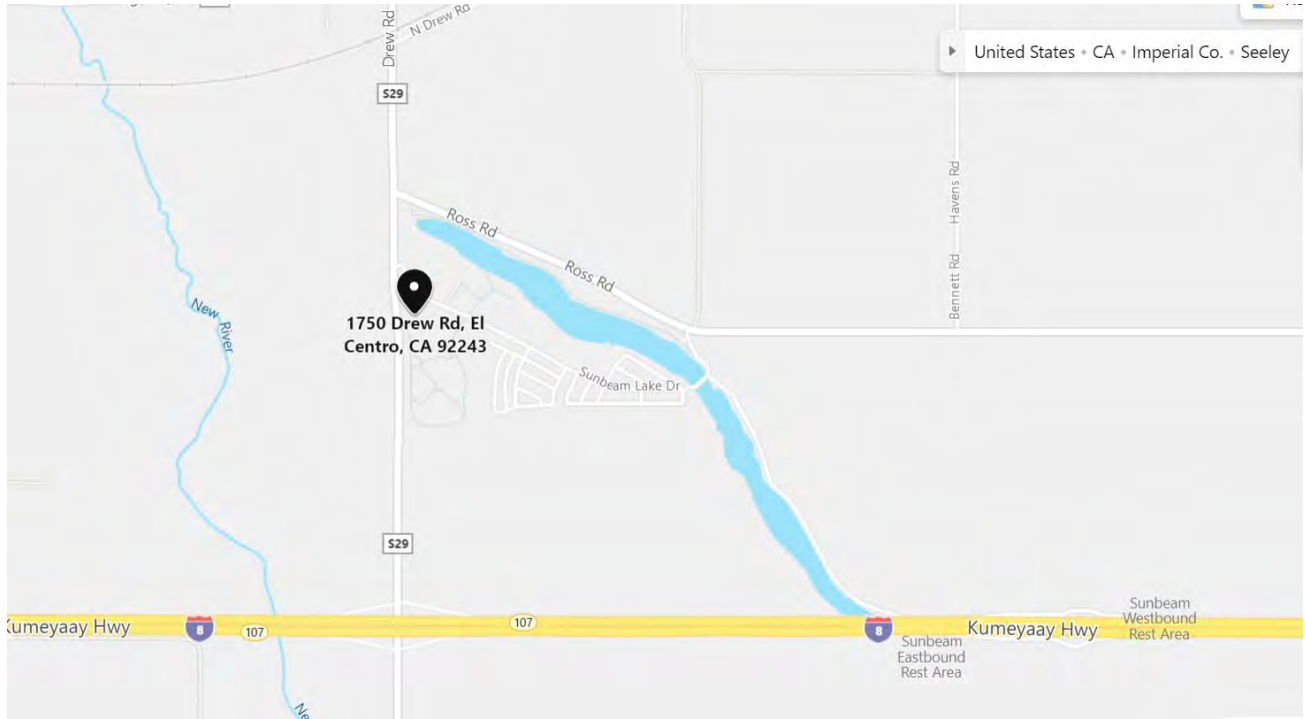

SUNBEAM LAKE WADING AREA



INFORMATION FOR BIDDERS

1. Preparation of Bid Form. COUNTY invites bids on the form attached to be submitted at such time and place as is stated in the form *Notice to Contractors Calling for Bids*. All blanks in the bid form must be appropriately completed, and all prices must be stated in both words and figures. All bids must be submitted in sealed envelopes bearing on the outside the name of the bidder, the bidder's address, and the name of the project for which the bid is submitted. It is the sole responsibility of the bidder to see that the bid is received by COUNTY prior to the date and time specified for opening bids. Any bid received after the scheduled closing time for receipt of bids will be returned to the bidder unopened.
2. Bid Security. Each bid shall be accompanied by a certified or cashier's check payable to COUNTY or a satisfactory bid bond in favor of COUNTY executed by the bidder as principal and a satisfactory surety company as surety, in an amount not less than ten percent (10%) of the maximum amount of the bid. The check or bid bond shall be given as guarantee that the bidder shall execute the contract if it be awarded to it in conformity with the contract documents and shall provide the surety bond or bonds as specified therein within ten (10) days after notification of the award of the contract to the bidder.
3. Signature. The bid must be signed in the name of the bidder and must bear the signature in longhand of the person or persons duly authorized to sign the bid.
4. Modifications. Changes in or additions to the bid form, recapitulations of the work bid upon, alternative proposals, or any other modification of the bid form which is not specifically called for in the contract documents may result in COUNTY's rejection of the bid as not being responsive to the invitation to bid. No oral or telephonic modification may be considered.

Any proposed modifications of a bidder's bid must be in writing and received by COUNTY prior to the date and time specified for opening bids.
5. Erasures. The bid submitted must not contain any erasures, interlineations, or other corrections unless each such correction is suitably authenticated by affixing in the margin immediately opposite the correction and the surname, or surnames of the person or persons signing the bid.
6. Examination of Site and Contract Documents. Each bidder shall visit the site of the proposed work and fully acquaint itself with the conditions relating to the construction and labor so that it may fully understand the facilities, difficulties and restrictions attending the execution of the work under the contract. Bidders shall thoroughly examine and be familiar with the drawings and specifications. The failure or omission of any bidder to receive or examine any contract documents, form, instrument, addendum or other document, or to visit the site and acquaint itself with conditions there existing, shall in no way relieve any bidder from obligations with respect to its bid or to the contract. The submission of a bid shall be taken as *prima facie* evidence of compliance with this section.
7. Withdrawal of Bids. Any bidder may withdraw its bid either personally, by written request, or by telegraphic request confirmed in the manner specified above at any time prior to the scheduled closing time for receipt of bids.
8. Relief from Mistake in Bid. The attention of bidders is called to Public Contracts Code sections 5100 to 5104, particularly the requirements of section 5103 which requires that grounds for relief from a mistaken bid require written notice to the public entity within five (5)

working days after the opening of the bids of mistake and such notice shall detail how the mistake occurred. Please note that a bidder shall not be relieved of its bid unless the elements of Public Contract Code section 5103 are met and the written consent of COUNTY is obtained and/or by order of a court of competent jurisdiction.

9. Agreements and Bonds. The agreement form which the successful bidder, as Contractor, will be required to execute, and the forms and amounts of the surety bonds which it will be required to furnish at the time of execution of the agreements, are included in the contract documents and should be carefully examined by the bidder. The required number of executed copies of the *Agreement*, the *Performance Bond*, and the *Payment Bond* for County Projects is as specified in the *Special Conditions*.
10. Interpretation of Plans and Documents. If any person contemplating submitting a bid for the proposed contract is in doubt as to the true meaning of any part of the drawings, specifications or other contract documents, or finds discrepancies in or omissions from the drawings and specifications, he or she shall submit to COUNTY a written request for an interpretation or correction thereof no less than ten (10) days prior to the bid opening. The person submitting the request will be responsible for its prompt delivery. Any interpretations or correction of the contract documents will be made only by addendum duly issued, and a copy of such addendum will be mailed or delivered to each person receiving a set of the contract documents. No oral interpretation of any provision in the contract documents will be made to any bidder. The interpretation of Plans and documents upon bid award shall be addressed in accordance with Article 2 of the "General Conditions."
11. Bidders Interested in More Than One Bid. No person, firm, or corporation shall be allowed to make, or file, or be interested in more than one bid for the same work unless alternate bids are specifically called for. A person, firm, or corporation that has submitted a sub-proposal to a bidder, or that has quoted prices of materials to a bidder, is not thereby disqualified from submitting a sub-proposal or quoting prices to other bidders or make a prime proposal.
12. Award of Contract. COUNTY reserves the right to reject any or all bids, or to waive any irregularities or informalities in any bids or in the bidding. The award of the contract, if made by COUNTY, will be to the lowest responsible bidder therefore. Award of the contract may be on **January 2021 (tentative)**, and an Agreement shall be presented to the successful bidder at that time. Successful bidder shall then have ten (10) days to execute the Agreement and provide all payment and performance bonds required for this project. Please note that a posted tabulation may be a preliminary tabulation which has not been reviewed for responsiveness and responsibility. It is possible that the lowest bidder will not be awarded the contract because of non-responsiveness or non-responsibility.
13. Alternates. If alternate bids are called for, the contract may be awarded at the election of the governing board to the lowest responsible bidder on the base bid, or on the base bid and any alternate or combination of alternates.
14. Bidder Contact Information. The bidder shall submit complete name, address and phone listings, (including fax), and contact person at bidder's company, provide a complete list of all personnel, subcontractors, and other agencies that will be assigned to this project and the responsibility that each will have.
15. Listing Subcontractors. Each bidder shall submit with its sealed bid a list of the proposed subcontractors on this project as required by the Subletting and Subcontracting Fair Practices Act (Pub. Cont. Code, § 4100, et seq.). Forms for this purpose are furnished with the contract documents.

16. Workers Compensation and Prevailing Wage Compliance.

16.1 Workers Compensation. In accordance with the provisions of Labor Code section 3700 *et. seq.* Contractor shall secure the payment of compensation to its employees. Contractor shall sign and file with COUNTY the following certificates prior to performing the work under this contract: "I am aware of the provisions of section 3700 of Labor Code which require every employer to be insured against liability for workers compensation or to undertake self-insurance in accordance with the provisions of that code, and I will comply with such provisions before commencing the performance of the work of this contract." The form of such certificate is included as a part of the contract documents.

16.2 Prevailing Wage Compliance. Contractor and its subcontractors shall pay all workers employed on the Project the rates determined by the Director of the California Department of Industrial Relations (DIR). Copies of the State prevailing rate of per diem wages are on file with the Department of Industrial Relations, Division of Apprenticeship Standards, 445 Golden Gate Avenue, San Francisco, California, and at COUNTY's Department of Public Works, and are available to Contractor and any other interested party upon request. Contractor shall post the prevailing rate of per diem wages to be posted at the Project site.

16.3 For those Projects subject to Department of Industrial Relations (DIR) Monitoring and Enforcement, be advised that the Contractor is responsible for submitting certified payroll records directly to the State Compliance Monitoring Unit (CMU). CMU is a new component within the State Division of Labor Standards Enforcement (DLSE) that was created to monitor and enforce prevailing wage requirements on public works projects that receive state bond funding and on other projects that are legally required to use the CMU. The CMU began operations on January 1, 2012, following the recent adoption of AB 436 and approval of revisions to program regulations. By actively monitoring compliance on an ongoing basis while work is being performed, the CMU will play a special role in ensuring that public works construction workers are promptly paid the proper prevailing wage rates and in helping maintain a level playing field for contractors who comply with the law.

Effective Date and Applicability: The laws and regulations that govern the new program are effective January 1, 2012. Only projects for which the public works contract is awarded on or after January 1, 2012 are subject to the CMU requirements. For further information concerning compliance monitoring please visit the website located at: <http://www.dir.ca.gov/dlse/cmu/cmu.html>

17. Substitution of Security. Contractors may substitute securities in place of retained funds withheld by COUNTY in accordance with the provisions of Cal. Pub. Contract Code section 22300.

18. Contractor's Pre-Bid Conference.

18.1 A Pre-Bid Conference will be held on the following date: **Tuesday, December 8, 2020 at 10:00 a.m** at:

**SUNBEAM LAKE WADING AREA IMPROVEMENTS
LOCATED AT 1750 DREW ROAD, EL CENTRO, CA 92243
Contact Person(s): Jenell Guerrero, MPA – Administrative Analyst III
Telephone: (442) 265-1818 or (760) 604-2162**

18.2 Attendance at the pre-bid facility walkthrough is **MANDATORY**. *Any firm that does not attend the mandatory site visit/briefing shall not be eligible to submit a bid proposal.*

- 18.3 Before submitting a bid, ALL BIDDERS are required to examine the project site and fully inform themselves as to all existing site conditions and limitations. The bid proposal shall include the cost of all items necessary for the construction of the Project. Bidder shall not receive any additional compensation for costs resulting from conditions that Bidder could have discovered with due diligence prior to submitting a bid.
- 18.4 In accordance with Paragraph 10 of the Information for Bidders, any questions presented at the Pre-Bid Conference must be in writing and received by COUNTY from General Contractor or subcontractor submitting a Bid on or before **December 18, 2020 at 2:00 p.m.** in the Public Works office located at 155 South 11th Street, El Centro, California, 92243 or via email to appropriate contact personnel.

19. Calendar of Events (Subject to change).

| | | |
|------|---|---|
| 19.1 | Bid packages available | <u>November 18, 2020</u> |
| 19.2 | <u>MANDATORY</u> Pre-Bid Facility Walkthrough | <u>December 8, 2020</u> <u>at 10:00 a.m.</u> |
| 19.3 | Return of Written Plans, Document Questions, and Substitution Requests. <u>Please be advised that Substitution Requests submitted after the due date may render this bid unresponsive.</u> | <u>December 10, 2020</u> <u>at 3:00 p.m.</u> |
| 19.4 | Bid package, inclusive of completed bid forms, and bid bond required to be submitted hereunder must be received by COUNTY on or before at: Clerk of the Board 940 Main Street, Suite 209 El Centro, CA 92243 Phone: (760) 482- 4220 | <u>December 18, 2020</u> <u>at 2:00 p.m.</u> |
| 19.5 | Bid Opening in Board Chambers | <u>December 18, 2020</u> <u>at 2:00 p.m.</u> |
| 19.6 | Board of Supervisors review and consideration of award on approximately | <u>January 2021</u> <u>(Tentative)</u> |
| 19.7 | Execution of Contract | <u>January 2021</u> <u>(Tentative)</u> |
| 19.8 | Commencement of construction on or before | <u>February 2021</u> <u>(Tentative)</u> |
| 19.9 | Completion of construction | <u>April 2021</u> <u>(Tentative)</u> |

BID FORM

TO: Acting by and through its Board of Supervisors, hereinafter called COUNTY.

1. Pursuant to and in compliance with your *Notice to Contractors Calling for Bids* and the other documents relating thereto, the undersigned bidder, having familiarized itself with the terms of the contract, the local conditions affecting the performance of the contract, and the cost of the work at the place where the work is to be done, and with the drawings and specifications and other contract documents, hereby proposes and agrees to perform, within the time stipulated by the contract, including all of its component parts and everything required to be performed, and to provide and furnish any and all of the labor, materials, tools, expendable equipment and all utility and transportation services necessary to perform the contract and complete it in a workmanlike manner, all of the work required in connection with the

SUNBEAM LAKE WADING AREA IMPROVEMENTS LOCATED AT 1750 DREW ROAD, EL CENTRO, CA 92243

COUNTY PROJECT NO. 6579PKS

All in strict conformity with the drawings and specifications and other contract documents, including addenda nos., _____, _____, _____, and _____, on file at the office of Public Works for the total sum of _____ Dollars (\$_____), hereinafter called the *Base Bid Price*.

Warning - If an addendum or addenda have been issued by the Department and not noted above as being received by the bidder, this proposal may be rejected.

COUNTY reserves the right to make award or any combination of base bid process plus deductive bid items as COUNTY determines to be in its best interest.

ENGINEER'S OPINION OF PROBABLE QUANTITY BASE BID

| ITEM # | ITEM DESCRIPTION | UNIT | ESTIMATED QUANTITY | UNIT PRICE | TOTAL |
|--------|--|------|--------------------|------------|-------|
| 1 | Mobilization/ Demobilization, Temporary Facilities, Construction Sign, Insurance, Bonds, Taxes, Permits, Fees and Similar Expenses | LS | 1 | | |
| 2 | Cut New Spillway-Existing Curb | LS | 1 | | |
| 3 | Sprinkler Lines | LF | 200 | | |
| 4 | Remove & Replant Trees | EA | 1 | | |
| 5 | Clear & Grub Cove for earth fill | LS | 1 | | |
| 6 | Excavation | CY | 1,125 | | |
| 7 | Fine grade | SF | 10,125 | | |

| | | | | | |
|----|--------------------------------------|----|--------|--|--|
| 8 | Trench for Liner Anchor | LF | 606 | | |
| 9 | RPE Liner | SF | 10,125 | | |
| 10 | HDPE Batten Anchor | LF | 17 | | |
| 11 | Sand Cover | CY | 375 | | |
| 12 | Fine Grade | SF | 10,125 | | |
| 13 | Perimeter Walk Path | SF | 2,000 | | |
| 14 | 4" SDR35PVC | LF | 160 | | |
| 15 | Spillway to Lake | LS | 1 | | |
| 16 | Grated inlet and drain | EA | 2 | | |
| 17 | 4" dia. Gate valve and riser w/cover | EA | 1 | | |
| 18 | New Chlorinator | LS | 1 | | |

TOTAL BASE BID: _____

Warning - If an addendum or addenda have been issued by the Department and not noted above as being received by the bidder, this proposal may be rejected.

COUNTY reserves the right to make award or any combination of base bid process plus deductive bid items as COUNTY determines to be in its best interest.

2. It is understood that COUNTY reserves the right to reject this bid and that this bid shall remain open and not be withdrawn for the period specified in the Notice to Contractors Calling for Bids.
3. The required bid security is hereto attached.
4. The required list of proposed subcontractors is attached hereto.
5. It is understood and agreed that if written notice of the acceptance of this bid is mailed, telegraphed, or delivered to the undersigned after the opening of the bid, and within the time this bid is required to remain open, or at any time thereafter before this bid is withdrawn, the undersigned will execute and deliver to COUNTY a contract in the form attached hereto in accordance with the bid as accepted, and that it will also furnish and deliver to COUNTY the Performance Bond and Payment Bond for the Public Works as specified, all within ten (10) days after receipt of notification of award, and that the work under the contract shall be commenced by the undersigned bidder, if awarded the Contractor, on the date to be stated in COUNTY's Notice to Contractors to Proceed, and shall be completed by the Contractor in the time specified in the contract documents.
6. Notice of acceptance or requests for additional information should be addressed to the undersigned at the address identified in Paragraph 8 below.

7. Print/type the names of all persons interested in the foregoing proposal as principals in the space provided below:

(IMPORTANT NOTICE: If bidder or other interested person is a corporation, state legal name of corporation, also names of the president, secretary, treasurer, and manager thereof; if a co-partnership, state true name of firm, also names of all individual co-partners composing firm; if bidder or other interested person is an individual, state first and last names in full.)

8. Licensed in accordance with act providing for the registration of Contractors:

License No. _____

Classification (s): _____

DIR Registration No. _____

Gross annual receipts for the firm: _____

Years in business: _____

Age of firm: _____

9. The undersigned certifies that he/she is now licensed in the appropriate trade in accordance with the provisions of the Contractor's License Law of the State of California, and the number of said license is _____ and that said license expires _____, 20__.

1. By my signature on this proposal I certify, under penalty or perjury under the laws of the State of California, that the foregoing questionnaire and statements of Public Contract Code sections 10162, 10232 and 10285.1 are true and correct and that the bidder has complied with the requirements of section 8103 of the Fair Employment and Housing Commission Regulations (Chapter 5, Title 2 of the California Administrative Code). By my signature on this proposal I further certify, under penalty or perjury under the laws of the State of California and the United States of America, that the Non-collusion Affidavit required by Title 23 United States Code, section 112 and Public Contract Code section 7106; and the Title 49 Code of Federal Regulations, Part 29 Debarment and Suspension Certification are true and correct.

Date: _____

Proper Name of Bidder

By: _____
(Signature of bidder)

(Print/type signator's name)

(Print/type title)

NOTE: If bidder is a corporation, the legal name of the corporation shall be set forth above, together with the signatures of authorized officers or agents, and the document shall bear the corporate seal; if bidder is a partnership, the true name of the firm shall be set forth above, together with the signature of the partner or partners authorized to sign contracts on behalf of the partnership; and if bidder is an individual, his/her signature shall be placed above.

Business Address: _____

Place of Residence: _____

Telephone: _____

Fax Number: _____

**NON-COLLUSION AFFIDAVIT TO BE EXECUTED
BY BIDDER AND SUBMITTED WITH BID**

State of California

County of Imperial

_____ [name of individual], being first duly sworn,
deposes and says that he or she is _____ [title of individual] of
_____ [name of business] the party making the
foregoing bid that the bid is not made in the interest of, or on behalf of, any undisclosed
person, partnership, company, association, organization, or corporation; that the bid is
genuine and not collusive or sham; that the bidder has not directly or indirectly induced or
solicited any other bidder to put in a false or sham bid, and has not directly or indirectly
colluded, conspired, connived, or agreed with any bidder or anyone else to put in a sham
bid, or that anyone shall refrain from bidding; that the bidder has not in any manner, directly
or indirectly, sought by agreement, communication, or conference with anyone to fix the bid
price of the bidder or any other bidder, or to fix any overhead, profit, or cost element of the
bid price, or of that of any other bidder, or to secure any advantage against the public body
awarding the contract of anyone interested in the proposed contract; that all statements
contained in the bid are true; and, further, that the bidder has not, directly or indirectly,
submitted his or her bid price or any breakdown thereof, or the contents thereof, or divulged
information or data relative thereto, or paid, and will not pay, any fee to any corporation,
partnership, company association, bid depository, or to any member or agent thereof to
effectuate a collusive or sham bid.

Signature

DESIGNATION OF SUBCONTRACTORS

In compliance with the Subletting and Subcontracting Fair Practices Act (Ch. 4 (commencing at section 4100), div. 2, part 1 of the Cal. Pub. Cont. Code) and any amendments thereof, each bidder shall set forth below: (a) the name and the location of the place of business of each subcontractor who will perform work or labor or render service to the prime Contractor in or about the construction of the work or improvement to be performed under this contract or subcontract licensed by the State of California who, under subcontractor to the prime Contractor, specialty fabricates and installs a portion of the work or improvement according to detailed drawings contained in the plans and specifications in an amount in excess of one-half of one percent (1/2%) of the prime Contractor's total bid; and (b) the portion of the work which will be done by each subcontractor under this act. The prime Contractor shall list only one subcontractor for each such portion as is defined by the prime Contractor in this bid.

If prime Contractor fails to specify a subcontractor or if a prime Contractor specifies more than one subcontractor for the same portion of work to be performed under the contract in excess of one-half of one percent (1/2%) of the prime Contractor's total bid, the bidder shall be deemed to have agreed that it is fully qualified to perform that portion itself, and that the bidder shall perform that portion itself.

No prime Contractor whose bid is accepted shall (a) substitute any subcontractor, (b) permit any subcontractor to be voluntarily assigned or transferred or allow it to be performed by any one other than the original subcontractor listed in the original bid, or (c) sublet or subcontract any portion of the work in excess of one-half of one percent (1/2%) of the prime Contractor's total bid as to which his original bid did not designate a subcontractor, except as authorized in *Subletting and Subcontracting Fair Practices Act*. Subletting or subcontracting of any portion of the work in excess of one-half of one percent (1/2%) of the prime Contractor's total bid as to which no subcontractor was designated in the original bid shall only be permitted in cases of public emergency or necessity, and then only after a finding reduced to writing as a public record of the authority awarding this contract setting forth the facts constituting the emergency or necessity.

If all work is to be done without subcontractors, write "None" in the following space:

| Type of Work Subcontractor Will Do | Name under which Subcontractor is Licensed | Address of Office, and Telephone No. | Classification, License No. & DIR Registration No. |
|--|--|---|--|
| | | | |
| | | | |
| | | | |
| | | | |

| Type of Work Subcontractor Will Do | Name under which Subcontractor is Licensed | Address of Office and Telephone No. | Classification, License No. & DIR Registration No. |
|------------------------------------|--|-------------------------------------|--|
| | | | |
| | | | |
| | | | |
| | | | |

Suppliers

| Name of Supplier | Address and Telephone No. | Type of Material |
|------------------|---------------------------|------------------|
| | | |
| | | |
| | | |
| | | |
| | | |
| | | |

(Proper Name of Bidder)

By: _____
(Signature of bidder)

(Print/type signator's name)

(Print/type title)

PUBLIC CONTRACT CODE SECTION 10162 QUESTIONNAIRE

In accordance with Public Contract Code section 10162, the Bidder shall complete, under penalty of perjury, the following questionnaire:

Has the bidder, any officer of the bidder, or any employee of the bidder who has a proprietary interest in the bidder, ever been disqualified, removed or otherwise prevented from bidding on, or completing a federal, state or local government project because of a violation of law or a safety regulation?

Yes _____ No _____

If the answer is yes, explain the circumstances in the following space.

PUBLIC CONTRACT SECTION 10232 STATEMENT

In accordance with Public Contract Code section 10232, the Contractor hereby states, under penalty of perjury, that no more than one final unappealable finding of contempt of court by a federal court has been issued against the Contractor within the immediately preceding two year period because of the Contractor's failure to comply with an order of a federal court which orders the Contractor to comply with an order of the National Labor Relations Board.

TITLE 23, UNITED STATES CODE, SECTION 112 NON-COLLUSION AFFIDAVIT

In accordance with Title 23, United States Code, section 112, the bidder hereby states under penalty of perjury, that he has not, either directly or indirectly, entered into any agreement, participated in any collusion, or otherwise taken any action in restraint of free competitive bidding in connection with this contract.

Note: The above Statement questionnaire, and Non-Collusion Affidavit are part of the Proposal. Signing this Proposal on the signature portion thereof shall also constitute Signature of this Statement, Questionnaire, and Non-Collusion Affidavit.

Bidders are cautioned that making a false certification may subject the certifier to criminal prosecution.

PUBLIC CONTRACT CODE SECTION 10285.1 STATEMENT

In accordance with Public Contract Code section 10285.1 (Chapter 376, Stat. 1985), the bidder hereby declares under penalty of perjury under the laws of the State of California that the bidder has _____, has not _____ been convicted within the preceding three (3) years of any offenses referred to in that section, including any charge of fraud, bribery, collusion, conspiracy, or any other act in violation of any state or federal antitrust law in connection with the bidding upon, award of, or performance of, any public works contract, as defined in Public Contract Code section 1101, with any public entity, as defined in Public Contract Code section 1100, including the Regents of the University of California or the Trustees of the California State University. The term "bidder" is understood to include any partner, member, officer, director, responsible managing officer, or responsible managing employee thereof, as referred to in section 10285.1

NOTE: THE BIDDER MUST PLACE A CHECK MARK AFTER "HAS" or "HAS NOT" IN ONE OF THE BLANK SPACES PROVIDED.

THE ABOVE STATEMENT IS PART OF THE PROPOSAL. SIGNING THIS PROPOSAL ON THE SIGNATURE PORTION THEREOF SHALL ALSO CONSTITUTE SIGNATURE OF THIS STATEMENT.

BIDDERS ARE CAUTIONED THAT MAKING A FALSE CERTIFICATION MAY SUBJECT THE CERTIFIER TO CRIMINAL PROSECUTION.

**CONTRACTOR'S CERTIFICATE
REGARDING WORKERS COMPENSATION**

Labor Code section 3700 in relevant part provides:

"Every employer except the State shall secure the payment of compensation in one or more of the following ways:

- (a) By being insured against liability to pay compensation in one or more insurers duly authorized to write compensation insurance in this State.

- (b) By securing from the Director of Industrial Relations a *Certificate of Consent to Self-Insure*, either as an individual employer, or as one employer in a group of employers, which may be given upon furnishing proof satisfactory to the Director of Industrial Relations of ability to be self-insured and to pay any compensation that may become due to his or her employees."

I am aware of the provisions of section 3700 of the Labor Code which require every employer to be insured against liability for workers compensation or to undertake self-insurance in accordance with the provisions of that Code, and I will comply with such provisions before commencing the performance of the work of this contract.

(Proper Name of Bidder)

By: _____
(Signature of bidder)

(Print/type signator's name)

(Print/type title)

(In accordance with Article 5 (commencing at section 1860), Chapter 1, Part 7, Division 2 of the Labor Code, the above certificate must be signed and filed with the awarding body prior to performing any work under this contract.)

BID BOND

KNOW ALL MEN BY THESE PRESENTS, that we _____ as Principal, and as Surety, are held and firmly bound unto the _____ County, hereinafter called COUNTY, in the penal sum of TEN PERCENT (10%) OF THE TOTAL AMOUNT OF THE BID of the Principal submitted to COUNTY for the work described below for the payment of which sum in lawful money of the United States, well and truly to be made, we bind ourselves, our heirs, executors, administrators, successors and assigns, jointly and severally, firmly by these presents.

THE CONDITION OF THIS OBLIGATION IS SUCH that whereas the Principal has submitted the accompanying bid dated _____, 20 _____, for

**SUNBEAM LAKE WADING AREA IMPROVEMENTS
LOCATED AT 1750 DREW ROAD, EL CENTRO, CA 92243**

COUNTY PROJECT NO. 6579PKS

NOW, THEREFORE, if the Principal shall not withdraw said bid within the period specified therein after the opening of the same, or, if no period be specified, within ninety (90) days after said opening, and if the Principal is awarded the contract, and shall within the period specified therefore, or, if no period be specified, within five (5) days after the prescribed forms are presented to it for signature, enter into the written contract with COUNTY in accordance with the bid as accepted and give bond with good and sufficient surety or sureties, as may be required, for the faithful performance and proper fulfillment of such contract and for the payment for labor and materials used for the performance of the contract, or in the event of the withdrawal of said bid within the period specified or the failure to enter into such contract and give such bonds within the time specified, if the Principal shall pay COUNTY the difference between the amount specified in said bid and the amount for which COUNTY may procure the required work and/or supplies, if the latter amount be in excess of the former; together with all costs incurred by COUNTY in again calling for bids, then the above obligation shall be void and of no effect, otherwise to remain in full force and virtue.

Surety, for value received, hereby stipulates and agrees that no change, extension of time, alterations or addition to the terms of the contract on the call for bids, or to the work to be performed thereunder, or the specifications accompanying the same, shall in anywise affect its obligation under this bond, and it does hereby waive notice of any such change, extension of time, alteration or addition to the terms of said contract or the call for bids, or to the work, or to the specifications.

In the event suit is brought upon this bond by COUNTY and judgment is recovered, Surety shall pay all costs incurred by COUNTY in such suit, including reasonable attorneys' fees to be fixed by the Court.

IN WITNESS WHEREOF, the above-bound parties have executed this instrument under their several seals this _____ day of _____, 20 _____, the name and corporate seal of each corporate party being hereto affixed, and these presents duly signed by its undersigned representative, pursuant to authority of its governing body.

(Corporate Seal)

(Proper Name of Principal)

By: _____
(Signature)

(Print/type signator's name)

(Print/type title)

(Corporate Seal)

(Proper Name of Surety)

By: _____
(Signature)

(Print/type signator's name)

(Print/type title)

(Attached Attorney-In-Fact Certificate)

PERFORMANCE BOND

Whereas, The Board of Supervisors of the County of Imperial, State of California, and _____, (hereinafter designated as "principal") have entered into an agreement whereby principal agrees to install and complete certain designated public improvements, which said agreement, dated _____, 20____, and identified as project: **SUNBEAM LAKE WADING AREA IMPROVEMENTS LOCATED AT 1750 DREW ROAD, EL CENTRO, CA 92243; COUNTY PROJECT NO. 6759PKS**, is hereby referred to and made a part hereof; and

Whereas, Said principal is required under the terms of said agreement to furnish a bond for the faithful performance of said agreement.

Now, therefore, we, the principal and _____ (hereinafter designated as "surety"), are held and firmly bound unto the County of Imperial (hereinafter designated as "County") in the penal sum of _____ dollars (\$_____) lawful money of the United States, for the payment of which sum well and truly to be made, we bind ourselves, our heirs, successors, executors and administrators, jointly and severally, firmly by these presents.

The condition of this obligation is such that if the above-bounded principal, his or its heirs, executors, administrators, successors or assigns, shall in all things stand to and abide by, and well and truly keep and perform the covenants, conditions and provisions in the said agreement and any alteration thereof made as therein provided, on his or their part, to be kept and performed at the time and in the manner therein specified, and in all respects according to their true intent and meaning, and shall indemnify and save harmless County, its officers, agents and employees, as therein stipulated, then this obligation shall become null and void; otherwise it shall be and remain in full force and effect.

As a part of the obligation secured hereby and in addition to the face amount specified therefore, there shall be included costs and reasonable expenses and fees, including reasonable attorneys' fees, incurred by County in successfully enforcing such obligation, all to be taxed as costs and included in any judgment rendered.

The surety hereby stipulates and agrees that no change, extension of time, alteration or addition to the terms of the agreement or to the work to be performed thereunder or the specifications accompanying the same shall in anywise affect its obligations on this bond, and it does hereby waive notice of any such change, extension of time, alteration or addition to the terms of the agreement or to the work or to the specifications.

In witness whereof, this instrument has been duly executed by the principal and surety above named, on _____, 20_____.

Principal

BY: _____

Surety

[Attach Required Acknowledgement]

BY: _____

Attorney-In-Fact

PAYMENT BOND

Whereas, The Board of Supervisors of the County of Imperial, State of California, and _____(hereinafter designated as "the principal") have entered into an agreement whereby the principal agrees to install and complete certain designated public improvements, which agreement, dated _____, 20____, and identified as project **SUNBEAM LAKE WADING AREA IMPROVEMENTS LOCATED AT 1750 DREW ROAD, EL CENTRO, CA 92243; COUNTY PROJECT NO. 6759PKS**, is hereby referred to and made a part hereof; and

Whereas, Under the terms of the agreement, the principal is required before entering upon the performance of the work, to file a good and sufficient payment bond with the County of Imperial to secure the claims to which reference is made in Title 3 (commencing with section 9000) of Part 6 of Division 4 of the Civil Code.

Now, therefore, the principal and the undersigned as corporate surety, are held firmly bound unto the County of Imperial and all contractors, subcontractors, laborers, material suppliers, and other persons employed in the performance of the agreement and referred to in Title 3 (commencing with section 9000) of Part 6 of Division 4 of the Civil Code in the sum of _____ dollars (\$_____), for materials furnished or labor thereon of any kind, or for amounts due under the Unemployment Insurance Act with respect to this work or labor, that the surety will pay the same in an amount not exceeding the amount hereinabove set forth, and also in case suit is brought upon this bond, will pay, in addition to the face amount thereof, costs and reasonable expenses and fees, including reasonable attorneys' fees, incurred by the County of Imperial in successfully enforcing this obligation, to be awarded and fixed by the court, and to be taxed as costs and to be included in the judgment therein rendered.

It is hereby expressly stipulated and agreed that this bond shall inure to the benefit of any and all persons, companies, and corporations entitled to file claims under Title 3 (commencing with section 9000) of Part 6 of Division 4 of the Civil Code, so as to give a right of action to them or their assigns in any suit brought upon this bond.

Should the condition of this bond be fully performed, then this obligation shall become null and void, otherwise it shall be and remain in full force and effect.

The surety hereby stipulates and agrees that no change, extension of time, alteration, or addition to the terms of the agreement or the specifications accompanying the same shall in any manner affect its obligations on this bond, and it does hereby waive notice of any such change, extension, alteration, or addition.

In witness whereof, this instrument has been duly executed by the principal and surety above named, on _____, 20_____.

Principal

BY: _____

Surety

[Attach Required Acknowledgement]

BY: _____

Attorney-In-Fact

CONTENTS OF GENERAL CONDITIONS

| | | |
|-------------|---|----|
| Article 1. | Definitions | 30 |
| Article 2. | Drawings and Specifications | 30 |
| Article 3. | Copies Furnished | 30 |
| Article 4. | Ownership of Drawings | 30 |
| Article 5. | Detail Drawings and Instructions | 30 |
| Article 6. | Time for Completion and Damages for Delay | 31 |
| Article 7. | Progress Schedule | 31 |
| Article 8. | Contract Security | 31 |
| Article 9. | Assignment | 31 |
| Article 10. | Prohibited Interests | 31 |
| Article 11. | Separate Contracts | 32 |
| Article 12. | Subcontracting | 32 |
| Article 13. | Defaults & Remedies | 32 |
| Article 14. | Warranties | 34 |
| Article 15. | Notices and Reports | 35 |
| Article 16. | Workers | 35 |
| Article 17. | Prevailing Wages & Payroll Records | 36 |
| Article 18. | Apprentices | 37 |
| Article 19. | Hours of Work | 37 |
| Article 20. | Insurance Coverages | 38 |
| Article 21. | Special Insurance Requirements | 38 |
| Article 22. | Insurance Endorsements, Clauses & Information | 39 |
| Article 23. | Proof of Insurance | 39 |
| Article 24. | Choice of Law | 40 |
| Article 25. | Permits and Licenses | 40 |
| Article 26. | Easements | 40 |
| Article 27. | Surveys | 40 |
| Article 28. | Excise Taxes | 40 |
| Article 29. | Patents and Royalties | 40 |
| Article 30. | Materials | 40 |
| Article 31. | Substitutions | 41 |
| Article 32. | Shop Drawings | 41 |
| Article 33. | Samples | 42 |
| Article 34. | Cost Breakdown and Periodical Estimates | 42 |
| Article 35. | Payments | 42 |
| Article 36. | Payment Withheld | 43 |
| Article 37. | Changes and Extra Work | 43 |
| Article 38. | Deductions for Uncorrected Work | 44 |

| | | |
|-------------|---|----|
| Article 39. | Payments by Contractor | 44 |
| Article 40. | Contractor's Supervision | 44 |
| Article 41. | Inspector's Field Office | 45 |
| Article 42. | Documents on Work | 45 |
| Article 43. | Utilities and Relocation | 45 |
| Article 44. | Sanitary Facilities | 46 |
| Article 45. | Trenches | 46 |
| Article 46. | Protection of Work and Property | 47 |
| Article 47. | Lay Out and Field Engineering | 48 |
| Article 48. | Cutting and Patching | 48 |
| Article 49. | Cleaning Up | 48 |
| Article 50. | Correction of Work | 48 |
| Article 51. | Access to Work | 48 |
| Article 52. | Occupancy | 48 |
| Article 53. | County's Inspector | 48 |
| Article 54. | Tests and Inspections | 49 |
| Article 55. | Soils Investigation Report | 49 |
| Article 56. | Architect/Engineer's and Construction Manager's Status | 50 |
| Article 57. | Indemnities | 50 |
| Article 58. | Provisions Required by Law Deemed Inserted | 50 |
| Article 59. | Labor - Employment Safety | 51 |
| Article 60. | Notice of Taxable Possessory Interest | 51 |
| Article 61. | Assignment of Unfair Business Practices Claims (Clayton Act & Cartwright Act) | 51 |
| Article 62. | Substitution of Security | 51 |
| Article 63. | Non-Discrimination & Disadvantaged Business Enterprise Program | 52 |
| Article 64. | Special Conditions | 52 |
| Article 65. | Contract Construction | 52 |
| Article 66. | Cognizance of Violations by County | 52 |
| Article 67. | Labor Standards Compliance Requirements | 53 |
| Article 68. | Conflict of Interest and Gratuities | 53 |
| Article 69. | Federal Contract Requirements | 54 |
| Article 70. | Ineligibility | 57 |
| Article 71. | Resolution of Claims | 57 |
| Article 72. | Miscellaneous | 58 |

GENERAL CONDITIONS

Article 1. DEFINITIONS

- (a) COUNTY and Contractor are those mentioned as such in the Agreement. They are treated throughout the Agreement as if they are of singular number and neuter gender.
- (b) Subcontractor, as used herein, includes those having direct contract with Contractor and one who furnishes material work to a special design according to plans and specifications of this work, but does not include one who merely furnishes material not so worked.
- (c) Surety is the person, firm, or corporation that executes as surety the *Contractor's Performance Bond and Payment Bond for the Public Works*.
- (d) Provide shall include "provide complete in place," that is, "furnish and install."
- (e) As Shown, As Indicated, As Detailed, refer to drawings accompanying these specifications.
- (f) Work of the Contractor or subcontractor includes labor or materials, or both.

Article 2. DRAWINGS AND SPECIFICATIONS

Contract Documents are complementary, and what is called for by one shall be as binding as if called for by all. The intention of documents is to include all labor and materials, equipment, and transportation necessary for the proper execution of work. Materials or work described in words which so apply have a well-known technical or trade meaning, and shall be deemed to refer to such recognized standards.

Interpretations. Figured dimensions on drawings shall govern, but work not dimensioned shall be as directed. Work not particularly shown or specified shall be the same as similar parts that are shown or specified. Large-scale details shall take precedence over smaller scaled drawings as to shape and details of construction. Specifications shall govern as to materials, workmanship, and installation procedures. Drawings and specifications are intended to be fully cooperative and to agree. However, if Contractor observes that drawings and specifications are in conflict, it shall promptly notify the Architect in writing, and any necessary changes shall be adjusted as provided in the contract for changes in work.

Misunderstanding of drawings and specifications shall be clarified by the Architect, whose decision shall be final.

Standards, Rules, and Regulations referred to are recognized printed standards, and shall be considered as one and a part of these specifications within limits specified.

Article 3. COPIES FURNISHED

Contractor will be furnished, free of charge, copies of drawings and specifications as set forth in *Special Conditions*. Additional copies may be obtained at cost of reproduction.

Article 4. OWNERSHIP OF DRAWINGS

All drawings, specifications, and copies thereof furnished by COUNTY are its property. They are not to be used on other work, and, with exception of signed contract sets, are to be returned to COUNTY on request at completion of work.

Article 5. DETAIL DRAWINGS AND INSTRUCTIONS

- (a) In case of ambiguity, conflict, or lack of information, Architect/Engineer shall furnish with reasonable promptness additional instructions, by means of drawings or otherwise, necessary for proper execution of work. All such drawings and instructions shall be consistent with contract documents, true developments thereof, and reasonably inferable therefrom.

- (b) Work shall be executed in conformity therewith, and Contractor shall do no work without proper drawings and instructions.

Article 6. TIME FOR COMPLETION AND DAMAGES FOR DELAY

The Parties recognize that time is of the essence of the Agreement and that COUNTY will suffer financial loss if the Work is not completed by the date set forth in paragraph 19.9 of the Information to Bidders section of this Agreement. The Parties also recognize the delays, expense and difficulties involved with proving in a legal proceeding the actual loss suffered by COUNTY if the Work is not completed on time. Accordingly, instead of requiring any such proof, the Parties agree that as damages for delay (but not as a penalty), Contractor shall pay COUNTY the sum of **four hundred four dollars (\$404.00) for each working day** the work remains uncompleted after the time specified in this article or any written extension, whichever is later. Contractor agrees that the damages are not manifestly unreasonable under the circumstances and agree that such sum is not intended as a penalty against Contractor.

Article 7. PROGRESS SCHEDULE

Immediately after being awarded contract, Contractor shall prepare an estimated progress schedule (using the Critical Path Method (CPM) through a software program selected by COUNTY but at Contractor's sole expense) and submit the schedule for COUNTY's approval. Schedule shall indicate graphically the beginning and completion dates of all phases of construction. An updated progress schedule shall be submitted to COUNTY on a monthly basis.

Article 8. CONTRACT SECURITY

Unless otherwise specified, Contractor shall furnish a surety bond in an amount equal to one hundred percent (100%) of the contract price as security for faithful performance of this contract, and shall furnish a separate bond in an amount equal to one hundred percent (100%) of the contract price as security for payment of persons performing labor and furnishing materials in connection with this contract. Aforesaid bonds shall be in form set forth in these contract documents. Upon request of Contractor, COUNTY will consider and accept multiple sureties on such bonds. COUNTY may reject at its discretion any bond issued by a surety that to COUNTY's satisfaction does not have a sufficient bond rating or history as a surety in the State of California to assure adequate security to COUNTY for the default of Contractor.

Article 9. ASSIGNMENT

Contractor shall not assign this contract or any part thereof without prior written consent of COUNTY. Any assignment of money due to or to become due under this contract shall be subject to a prior lien for services rendered or material supplied for performance of work called for under said contract in favor of all persons, firms, or corporations rendering such services or supplying such materials to the extent that claims are filed pursuant to the Civil Code, the Code of Civil Procedure, Public Contract Code and/or the Government Code.

Article 10. PROHIBITED INTERESTS

No official of COUNTY who is authorized in such capacity and on behalf of COUNTY to negotiate, make, accept or approve, or to take part in negotiating, making, accepting or approving, any architectural, engineering, inspection, construction, or material supply contract or any subcontract in connection with construction or project shall become directly or indirectly interested financially in this contract or in any part thereof. No officer, employee, architect, attorney, engineer, or inspector of or for COUNTY who is authorized in such capacity and on behalf of COUNTY to exercise any executive, supervisory, or other similar functions in connection with construction of project shall become directly or indirectly interested financially in this contract or in any part thereof.

Article 11. SEPARATE CONTRACTS

COUNTY reserves the right to let other contracts in connection with this work. Contractor shall afford other Contractors reasonable opportunity for introduction and storage of their materials and execution of their work and shall properly connect and coordinates its work with theirs.

If any part of Contractor's work depends for proper execution or results upon work of any other Contractor, the Contractor shall inspect and promptly report to Architect/Engineer any defects in such work that render it unsuitable for such proper execution and results. Contractor's failure so to inspect and report shall constitute its acceptance of other Contractor's work as fit and proper for reception of Contractor's work, except as to defects which may develop in other Contractor's work after execution of Contractor's work.

To ensure proper execution of its subsequent work, Contractor shall measure and inspect work already in place, and shall at once report to Architect any discrepancy between executed work and contract documents.

Contractor shall ascertain to its own satisfaction the scope of the project and nature of any other contracts that have been or may be awarded by COUNTY in prosecution of the project to the end that Contractor may perform its contract in the light of such other contracts, if any. Nothing herein contained shall be interpreted as granting to Contractor exclusive occupancy at site of project. Contractor shall not cause any unnecessary hindrance or delay to any other Contractor working on project. If simultaneous execution of any contract for the project is likely to cause interference with performance of some other contract or contracts, COUNTY shall decide which Contractor shall cease work temporarily and which Contractor shall continue or whether work can be coordinated so that Contractors may proceed simultaneously. COUNTY shall not be responsible for any damages suffered or extra costs incurred by Contractor resulting directly or indirectly from award or performance or attempted performance of any other contract or contracts on project, or caused by any decision or omission of COUNTY respecting the order of precedence in performance of contracts.

Article 12. SUBCONTRACTING

- (a) Contractor agrees to bind every subcontractor by terms of the contract as far as such terms are applicable to subcontractor's work. If Contractor shall subcontract any part of this contract, Contractor shall be as fully responsible to COUNTY for acts and omissions of Contractor's subcontractor and of persons either directly or indirectly employed by Contractor's subcontractor as it is for acts and omissions of persons directly employed by itself. Nothing contained in the contract documents shall create any contractual relation between any subcontractor and COUNTY.
- (b) COUNTY's consent to or approval of any subcontractor under this contract shall not in any way relieve Contractor of its obligations under this contract, and no such consent or approval shall be deemed to waive any provision of this contract.
- (c) Substitution or addition of subcontractors shall be permitted only as authorized by California Public Contract Code sections 4100, et seq.
- (d) Contractor represents and warrants that it and its subcontractors are not ineligible to work for COUNTY due to violations of Labor Code sections 1777.1 and 1777.7.

Article 13. DEFAULTS & REMEDIES

- (a) Default. In the event that (i) Contractor files a petition requesting relief under any bankruptcy act, or is adjudged as bankrupt, or makes a general assignment for the benefit of creditors or has a receiver appointed on account of its insolvency, or (ii) Contractor refuses

or is unable, for whatever reason, to supply enough properly skilled workers or proper materials to complete the Project, or (iii) Contractor fails to follow the directions of COUNTY, or (iv) Contractor fails to make prompt payment to its subcontractors and suppliers for materials or labor supplied or permits any lien to be imposed upon all or any portion of the Project, or (v) Contractor disregards any laws or orders of any public or private authority having jurisdiction over the Work or the Project, or (vi) Contractor fails to perform in accordance with any of the terms of this Agreement or breaches any provision of this Agreement, COUNTY may give notice of such failure or breach to Contractor, identifying the failure or breach of this Agreement. Should any such failure or breach continue for twenty-four (24) hours after delivery of notice without a good faith effort on the part of Contractor to commence all necessary corrective action, or should such a breach continue despite Contractor's efforts for forty-eight (48) hours, then at that time such failure shall be deemed a default by Contractor under this Agreement and COUNTY shall have all rights and remedies available at law or in equity, including the right to terminate this Agreement. Without limiting its rights and remedies, COUNTY may then proceed as follows:

- (1) Without terminating this Agreement or the obligations of Contractor hereunder as to all of the Work required to be performed or furnished by Contractor pursuant to this Agreement, COUNTY may require Contractor, at Contractor's expense, to cure such default(s) as may exist in the performance of Contractor's obligations hereunder within forty-eight (48) hours after such default(s) has/have occurred including but not limited to repairing, replacing, and correcting material or Work determined by COUNTY to be defective or not complying with the requirements of this Agreement. Should Contractor fail to timely repair, replace, and/or correct non-complying or defective materials and workmanship or otherwise cure its default(s) hereunder, and in the case of emergencies in which case COUNTY may act immediately if Contractor is not available or is not responding, and without further notice, COUNTY may make required repairs, replacements and other corrections or otherwise remedy the default by Contractor pursuant to Paragraph (2) below.
- (2) Without terminating this Agreement or the obligations of Contractor hereunder as to all of the Work required to be performed or furnished by Contractor pursuant to this Agreement, COUNTY may engage another contractor to perform such portion of Contractor's Work required pursuant to this Agreement or furnish any materials or other items required hereunder as COUNTY in its sole discretion may deem necessary to avoid delay in the progress of the Work, and in connection therewith, COUNTY may perform such Work or any portion thereof itself or have the same performed by others and COUNTY may procure all necessary materials, equipment or other items required for the continued progress of such Work. The costs incurred by COUNTY as a result of engaging another Contractor shall be deducted from the compensation payable pursuant to this Agreement and if COUNTY's costs exceed or may reasonably be anticipated to exceed the balance of the compensation due to Contractor for such work, such excess, or anticipated excess, shall be immediately due and owing from Contractor to COUNTY and may be withheld from any funds due to Contractor pursuant to this Agreement or any other agreement.
- (3) COUNTY may terminate Contractor's right to perform upon written notice and COUNTY shall then have the option of completing the Work or any portion thereof by exercise of its interest under the performance bond issued in favor by Contractor, or having such Work in whole or in part be completed by

others for Contractor's account. A calculation shall take place at the conclusion of the Project wherein to the degree the sum of COUNTY's costs and any amounts paid to complete the Project exceed the compensation payable pursuant to this Agreement, then any such excess shall be immediately due and owing from Contractor to COUNTY.

- (b) Damages. Contractor shall be liable for all damages suffered by COUNTY by reason of Contractor's default in any provision of this Agreement and the exercise of COUNTY of its option to terminate this Agreement shall not release Contractor of such liability. Contractor shall have no right to receive any further payment after a default has occurred until such time as the Work to be performed by Contractor pursuant hereto has been completed and accepted by COUNTY and damages suffered by COUNTY, if any, ascertained. Damages shall include by way of illustration, but not of exclusion, COUNTY's costs of completing the Work which exceeds the compensation payable pursuant to this Agreement, other general, liquidated, special or consequential damages, attorney fees, and costs.
- (c) Actions After Default. Should COUNTY exercise any of its options, remedies, or rights granted pursuant to the terms of this Agreement in the event of a default by Contractor, COUNTY at its sole election may, but shall not be obligated to, use any materials, supplies, tools or equipment on the work site which belong to CONTRACTOR to complete the Work required to be completed by Contractor, whether such work is completed by COUNTY or by others, and Contractor agrees that it shall not remove such materials, supplies, tools and equipment from the work site unless directed in writing by COUNTY to do so.
- (d) Limit on Force Majeure Damages. Contractor shall not be responsible for repairing or restoring damage to work caused by an act of God, provided that the work damaged is built in accordance with accepted and applicable building standards and the plans and specifications of COUNTY. In the event of such damage, COUNTY may, at its option, elect to terminate this Agreement. For purposes of this Agreement, an "act of God" shall be defined as an earthquake in excess of 3.5 on the Richter scale and a tidal wave.
- (e) No Limitation of Rights. The options and rights granted to COUNTY herein shall not be deemed as limitations upon the other rights and remedies of COUNTY in the event of a failure of performance or breach by Contractor, and COUNTY shall be entitled to exercise the rights and remedies hereinabove specified and all other rights and remedies which may be provided in this Agreement or by law or in equity, either cumulatively or consecutively, and in such order as COUNTY in its sole discretion shall determine.

Article 14. WARRANTIES

- (a) One-Year Warranty. Contractor agrees to provide a one-year warranty for all of its work and component parts and guarantees that all work shall be performed in a professional and workman-like manner and be free from defects. Contractor guarantees to timely correct all work performed by it under this Agreement which COUNTY determines to be defective in design, material, and/or workmanship within a period of one (1) year from the date of the completion of the Work. The warranties set forth in this Agreement shall be in addition to, and not in lieu of, all other statutory and case law warranties and obligations of Contractor. Contractor expressly agrees that all warranties made by Contractor, all obligations under this Agreement and all remedies for breach of such warranties shall survive this Agreement in the event it is terminated or expires for any reason prior to the running of the full warranty periods listed above.

Note: Product Warranty on specifications.

- (b) Materials. All materials furnished by Contractor shall be new, manufactured during the current year, of first quality, and carrying full manufacturer's warranty. Contractor shall be responsible for any expiration of manufacturer or other warranties of material or equipment being supplied for this Agreement. Contractor guarantees that all warranties of material and equipment shall become effective when the project is accepted by COUNTY's Board of Supervisors, not at time of installation by Contractor.
- (c) Manufacturers' Warranty Information. Contractor agrees to promptly provide such information and maintenance recommendations to COUNTY at the inception of Contractor's work to the extent such information is reasonably available. In the event of failure of Contractor to comply with above-mentioned conditions within one (1) week after being notified in writing, COUNTY is hereby authorized to proceed to have defects repaired and made good at expense of Contractor, who hereby agrees to pay costs and charges therefore immediately on demand.

Article 15. NOTICES AND REPORTS

- (a) All notices and reports under this Agreement shall be in writing and may be given by personal delivery or by mailing by certified mail, addressed as follows:

COUNTY
 Imperial County Department of Public Works
 Attention: Director
 155 South Eleventh Street
 El Centro, CA 92243

CONTRACTOR

Business Name:

With Copies to:

Imperial County Executive Office
 Attention: County Executive Officer
 940 West Main Street, Suite 208
 El Centro, CA 92243

Address:

And:

Imperial County Department of Human
 Resources and Risk Management
 Attention: Director
 940 West Main Street, Suite 101
 El Centro, CA 92243

- (b) Notices and reports under this Agreement may be given by personal delivery or by mailing by certified mail at such other address as either Party may designate in a notice to the other Party given in such manner. Any notice given by mail shall be considered given when deposited in the United States Mail, postage prepaid, addressed as provided herein.

Article 16. WORKERS

- (a) Contractor shall at all times enforce strict discipline and good order among its employees, and shall not employ on work any unfit person or anyone not skilled in work assigned to that person. Contractor shall at all times enforce rules and standards regarding sensitive information. Contractor shall not permit workers to touch or otherwise touch, read, review, copy, or access any sensitive or confidential information. Contractor shall be responsible for any worker violating sensitive information standards.

- (b) Any person in the employ of the Contractor whom COUNTY may deem incompetent or unfit shall be dismissed from work, and shall not again be employed on it except with written consent of COUNTY.
- (c) Contractor shall provide COUNTY with a list of all current employees. Contractor shall notify COUNTY of all new employees one week prior to their start date.
- (d) All Contractor's employees shall be required to comply with the work rules established for the project site; and shall be identified while on the premises by picture identification card furnished at his/her expense, indicating their name or number; and by shirt, blouse or smock indicating the company name or logo in print large enough to be easily read. Contractor's employees shall have effective communication skills to perform such tasks and communicate with the COUNTY and its representatives.
- (e) It shall be the responsibility of Contractor to ensure all workers do not access sensitive information. COUNTY shall have the right to perform a background check and clearance requirements of all workers that have access to sensitive information. Notwithstanding anything in this agreement to the contrary, the Contractor must comply with background check and clearance requirements of the California Department of Justice (DOJ) and the California Department of Motor Vehicles (DMV) relating to any Contractor employee who has physical access to any area which is either connected to, or contains records from, the DOJ criminal computer database, including without limitation, the California Law Enforcement Telecommunications System and the Criminal Offender Record Information, or the DMV computer database (collectively, "the Databases"). If requested by the COUNTY, the Contractor must provide to the COUNTY suitable documentation evidencing the Contractor's compliance with the policies, practices, and procedures of the DOJ and the DMV regarding background check and clearance requirements relating to access to the Databases.

Article 17. PREVAILING WAGE AND PAYROLL RECORDS

- (a) Contractor agrees to comply with sections 1775 and 1776 of the California Labor Code relating to the payment of prevailing wage and the maintenance of certified payroll records and to make the certified payroll records available for inspection at all reasonable hours at Contractor's principal office. For those Public Works Projects that are subject to the State Department of Industrial Relations (DIR), Division of Labor Standards Enforcement (DLSE) compliance monitoring and enforcement it is the Contractor's responsibility to submit certified payroll records directly to the state Compliance Monitoring Unit (CMU). More information concerning state compliance can be found at <http://www.dir.ca.gov/dlse/cmu/cmu.html>. The responsibility for compliance with these provisions is fixed with Contractor. Contractor understands and agrees that it shall, as a penalty to COUNTY, forfeit specific monetary fines for each worker paid less than the prevailing wage rates as determined by the Labor Commissioner for the work or craft in which the worker is employed for any Work done pursuant to this Agreement.
- (b) Notwithstanding paragraph (a), Contractor is not liable for any penalties pursuant to paragraph (a) when a subcontractor on the Project fails to pay its workers the general prevailing rate of per diem wages unless:
 - (1) Contractor had knowledge of that failure of the subcontractor to pay the specified prevailing rate of wages to those workers; or

(2) Contractor fails to comply with all of the following requirements:

- (A) The contract executed between Contractor and the subcontractor for the performance of Work on the Project shall include a copy of the provisions of California Labor Code sections 1771, 1775, 1776, 1777.5, 1813 and 1815; and
- (B) Contractor shall monitor the payment of the specified general prevailing rate of per diem wages by the subcontractor to the employees, by periodic review of the certified payroll records of the subcontractor; and
- (C) Upon becoming aware of the failure of the subcontractor to pay his or her workers the specified prevailing rate of wages, Contractor shall diligently take corrective action to halt or rectify the failure, including, but not limited to, retaining sufficient funds due the subcontractor for work performed on the public works project; and
- (D) Prior to making final payment to the subcontractor for Work performed on the Project, Contractor shall obtain an affidavit signed under penalty of perjury from the subcontractor that the subcontractor has paid the specified general prevailing rate of per diem wages to his or her employees on the Project and any amounts due pursuant to California Labor Code section 1813.
- (E) Prevailing Wage Compliance. Contractor and its subcontractors shall pay all workers employed on the Project the rates determined by the Director of the California Department of Industrial Relations (DIR). Copies of the State prevailing rate of per diem wages are on file with the Department of Industrial Relations, Division of Apprenticeship Standards, 445 Golden Gate Avenue, San Francisco, California, and at COUNTY's Department of Public Works, and are available to Contractor and any other interested party upon request. Contractor shall post the prevailing rate of per diem wages to be posted at the Project site.

Article 18. APPRENTICES

- (a) Contractor agrees to comply with sections 1777.5, 1777.6 and 1777.7 of the California Labor Code relating to the employment of apprentices and to provide COUNTY with copies of any contract award information and verified statements of the journeyman and apprentice hours performed pursuant to this Agreement as required by section 1777.5(e). The responsibility for compliance with these provisions is fixed with Contractor for all apprenticeable occupations, where journeymen in the craft are employed on the public work, in a ratio of not less than one (1) apprentice for each five (5) journeymen (unless an exemption is granted in accordance with section 1777.5) and Contractor and its subcontractors shall not discriminate among otherwise qualified employees as indentured apprentices on any public work solely on the ground of race, religious creed, color, national origin, ancestry, sex, or age, except as provided in California Labor Code section 3077. Only apprentices, as defined in California Labor Code section 3077, who are in training under apprenticeship standards and who have signed written apprentice agreements will be employed on public works in apprenticeable occupations. This section shall not be enforced if the not-to-exceed amount of this Agreement is less than thirty thousand dollars (\$30,000).
- (b) If the Project falls within the jurisdiction of California Labor Code section 1777.5, COUNTY shall, within five (5) days of the award, send a copy of the award to the Division of Apprenticeship Standards. In addition, COUNTY shall notify the Division of Apprenticeship Standards of a finding of any discrepancy regarding the ratio of apprentices to journeymen within five (5) days of the finding.

Article 19. HOURS OF WORK

Contractor agrees to comply with sections 1810 through 1815 of the California Labor Code and, when applicable, the Contract Work Hours and Safety Standards Act (40 USC §327 et seq.; 29 CFR Part 5) which provide that Contractor’s workers and its subcontractor’s workers may not be required or permitted to work more than eight (8) hours in any one (1) calendar day and forty (40) hours in any one (1) calendar week. Further, work performed by employees of Contractor or its subcontractor in excess of eight (8) hours per day, and forty (40) hours during any one (1) week, shall be compensated for all hours worked in excess of eight (8) hours per day at not less than one and one-half (1½) times the basic rate of pay. The responsibility for compliance with these provisions is fixed with Contractor. Contractor understands and agrees that it shall, as a penalty to COUNTY, forfeit specific monetary fines to COUNTY should Contractor or its subcontractors fail to comply with the provisions contained within this paragraph.

Article 20. INSURANCE COVERAGES

Contractor hereby agrees at its own cost and expense to procure and maintain, during the entire term of this Agreement and any extended term therefore, insurance in a sum acceptable to COUNTY and adequate to cover potential liabilities arising in connection with the performance of this Agreement and in any event not less than the minimum limit set forth as follows:

| <u>INSURANCE</u> | <u>MINIMUM LIMIT</u> |
|--|--|
| <u>Worker’s Compensation, Coverage A</u> | Statutory |
| <u>Employers Liability, Coverage B</u> | \$1,000,000.00 per accident for bodily injury or disease |

Commercial General Liability Including Contractual Liability

Operations, Products and Completed Operations:

| | |
|------------------------|---|
| Personal/Bodily Injury | \$1,000,000.00 / occurrence \$2,000,000.00 / aggregate |
| Property Damage | \$1,000,000.00 / occurrence \$2,000,000.00 / aggregate |

Commercial Automobile Liability
(owned, hired, & non-owned vehicles)

| | |
|---|----------------|
| Personal/Bodily Injury & Property Damage | \$1,000,000.00 |
|---|----------------|

| | |
|------------------------|-----------------------------------|
| Unemployment Insurance | To Be Determined by Scope of Work |
| Disability Insurance | To Be Determined by Scope of Work |
| Liability Insurance | To Be Determined by Scope of Work |

Article 21. SPECIAL INSURANCE REQUIREMENTS

(a) All insurance required under Article 20 shall:

- (1) Be procured from an insurer authorized to do business in California.
- (2) Be primary coverage as respects COUNTY and any insurance or self-insurance maintained by COUNTY shall be in excess of Contractor’s insurance coverage and shall not contribute to it.

- (3) Name COUNTY as an additional insured on all policies, except Workers' Compensation, and provide that COUNTY may recover for any loss suffered by COUNTY by reason of Contractor's negligence.
 - (4) State that it is primary insurance and regards COUNTY as an additional insured and contains a cross-liability or severability of interest clause.
 - (5) Not be canceled, non-renewed, or reduced in scope of coverage until after thirty (30) days written notice has been given to COUNTY. However, Contractor may not terminate such coverage until it provides COUNTY with proof that equal or better insurance has been secured and is in place. Cancellation or change without the prior written consent of COUNTY shall, at the option of COUNTY, be grounds for termination of this Agreement.
- (b) Additional Insurance Requirements.
- (1) Complete copies of certificates of insurance for all required coverages including additional insured endorsements and thirty-day (30-day) notice of cancellation clause endorsements shall be attached hereto as Exhibit E and incorporated herein as though fully set forth.
 - (2) COUNTY is to be notified immediately of all insurance claims. COUNTY is also to be notified if any aggregate insurance limit is exceeded.
- (c) Nothing in this, or any other provision of this Agreement, shall be construed to preclude Contractor from obtaining and maintaining any additional insurance policies in addition to those required pursuant to this Agreement.

Article 22. INSURANCE ENDORSEMENTS, CLAUSES, & INFORMATION

- (a) The comprehensive/commercial general liability insurance shall contain a provision of endorsements stating that such insurance:
- (1) Includes contractual liability;
 - (2) Does not contain a "pro rata" provision which looks to limit the insurer's liability to the total proportion that its policy limits bear to the total coverage available to the insured;
 - (3) Does not contain an "excess only" clause which requires the exhaustion of other insurance prior to providing coverage;
 - (4) Does not contain an "escape clause" which extinguishes the insurer's liability if the loss is covered by other insurance;
 - (5) Includes COUNTY, architect, and the construction manager as an additional insured;
 - (6) States that it is primary insurance and regards COUNTY as an additional insured and contains a cross-liability or severability of interest clause; and
 - (7) Does not contain any exclusion as to loss or damage to property caused by explosion or resulting from collapse of buildings or structures or damage to property underground, commonly referred to by insurers as the "XCU Hazards."
- (b) Certificates and insurance policies shall include the following clause: "This policy shall not be canceled or reduced in required limits of liability or amount of insurance until notice has

been mailed to COUNTY stating date of cancellation or reduction. Date of cancellation may not be less than thirty (30) days after date of mailing notice."

- (c) Certificates of insurance shall state, in particular, those insured, extent of insurance, location and operation to which insurance applies, expiration date, and cancellation and reduction notice.

Article 23. PROOF OF INSURANCE

Contractor shall not commence work nor shall it allow any subcontractor to commence work under this Agreement until Contractor has obtained all required insurance, certificates and endorsements, including but not limited to, Additional Insured Endorsements and thirty-days (30-days) Notice of Cancellation Clause endorsements have been delivered in duplicate to and approved by COUNTY. The above referenced insurance documents must be received by COUNTY on or before the effective date of this Agreement and shall be sent to the following addresses:

- (i) County of Imperial
Risk Management Department
940 Main Street, Ste 101
El Centro, CA 92243

and

- (ii) Department of Public Works
Attn: Director of Public Works
1002 State Street
El Centro, CA 92243

Article 24. CHOICE OF LAW

The laws of the State of California shall govern this Agreement. This Agreement is made and entered into in Imperial County, California. Any action brought by either Party with respect to this Agreement shall be brought in a court of competent jurisdiction within said County.

Article 25. PERMITS AND LICENSES

Permits and licenses necessary for prosecution of work shall be secured and paid for by Contractor, unless otherwise specified.

Article 26. EASEMENTS

Easements for permanent structures or permanent changes in existing facilities shall be secured and paid for by COUNTY, unless otherwise specified.

Article 27. SURVEYS

Surveys to determine location of property lines and corners will be supplied by COUNTY. Surveys to determine locations of construction, grading, and site work shall be provided by Contractor.

Article 28. EXCISE TAXES

If under federal excise tax law any transaction hereunder constitutes a sale on which a federal excise tax is imposed and the sale is exempt from such excise tax because it is a sale to a state or local government for its exclusive use, COUNTY, upon request, will execute a certificate of exemption which will certify: (a) that COUNTY is a political subdivision of the state for the purpose of such exemption; and (b) that the sale is for the exclusive use of COUNTY. No excise tax for such materials shall be included in any bid price.

Article 29. PATENTS AND ROYALTIES

Contractor shall hold and save COUNTY and its officers, agents, and employees harmless from liability of any nature or kind, including cost and expense, for or on account of any patented or unpatented invention, process, article, or appliance manufactured or used in the performance of this contract, including its use by COUNTY, unless otherwise specifically stipulated in the contract documents.

Article 30. MATERIALS

Except as otherwise specifically stated in this contract, Contractor shall provide and pay for all materials, labor, tools, equipment, water, light, power, transportation, superintendence, temporary constructions of every nature, and all other services and facilities of every nature whatsoever necessary to execute and complete this contract within the specified time.

Unless otherwise specified, all materials shall be new, and both workmanship and materials shall be of good quality.

Materials shall be furnished in ample quantities and at such times as to insure uninterrupted progress of work, and shall be stored properly and protected as required. Contractor shall be entirely responsible for damage or loss by weather or other causes to materials or work under this contract. No material, supplies, or equipment for work under this contract shall be purchased subject to any chattel mortgage or under a conditional sale or other agreement by which an interest herein or in any part thereof is retained by seller or supplier. Contractor warrants good title to all material, supplies, and equipment installed or incorporated in work, and agrees upon completion of all work to deliver premises, together with all improvements and appurtenances constructed or placed thereon by Contractor, to COUNTY free from any claims, liens, or charges. Contractor further agrees that neither Contractor nor any person, firm, or corporation furnishing materials or labor for any work covered by this contract shall have any right to lien upon premises or any improvement or appurtenance thereon, except that Contractor may install metering devices or other equipment of utility companies or of political subdivisions title to which is commonly retained by utility company or political subdivision. In event of installation of any such metering device or equipment, Contractor shall advise COUNTY as to owner thereof. Nothing contained in this Article, however, shall defeat or impair the right of persons furnishing material or labor under any bond given by Contractor for their protection or any rights under any law permitting such persons to look to funds due Contractor in hands of COUNTY, and this provision shall be inserted in all subcontracts and material contracts, and notice of its provisions shall be given to all persons furnishing material for work when no formal contract is entered into for such material.

See Comprehensive Specifications for material requirements.

Article 31. SUBSTITUTIONS

Whenever specifications for any material, product, thing, service, or process is indicated or specified by grade, patent or propriety name or by name of manufacturer, such specifications shall be deemed to be used for the purpose of facilitating the description of material, product, thing, service, or process desired, and shall be deemed to be followed by the words "or equal", and Contractor may, unless otherwise stated, offer any material, product, thing, service or process which shall be equal or better in every respect to that so indicated or specified. If the material, product, thing, service, or process offered by Contractor is not, in the opinion of COUNTY and Architect/Engineer, equal or better in every respect to that specified, then Contractor shall furnish the material, product, thing, service, or process specified. The burden of proof as to equality of any material, product, thing, service, or process shall rest with Contractor. Contractor shall only be authorized to substitute any designated material, product, thing, service or process required under this contract if such request, together with substantiating data for substitution of an "or equal" item is timely submitted in accordance with the Calendar of Events set forth under section 19.3 of the

“INFORMATION FOR BIDDERS” form and approval thereof is authorized in writing by COUNTY within the time frame set forth under Public Contract Code section 4104.5(a). Notwithstanding, in the event CONTRACTOR discovers after the stated substitution request filing deadline that a designated material, product, thing, service or process is no longer available and/or the use of the same is necessary to complete the project, CONTRACTOR may within thirty (30) days after award of the contract submit a “late substitution request”, together with substantiating data for substitution of an “or equal” item for COUNTY’s review and consideration. However, COUNTY shall have the sole discretion in granting such a late substitution request and shall not be required to accept the same even if the material, product, thing, service or process is equal or better in every respect.

It should be emphasized that a Contractor’s request to substitute an “equal” material, product, thing or service for one designated in the contract specifications and/or COUNTY’s subsequent written approval thereof, shall not in any way authorize an extension of time for performance of this contract. Moreover, in event Contractor furnishes a material, product, thing or service that is more expensive than that specified, the difference in cost of such material, product, thing, service or process, so furnished shall be borne solely by Contractor.

Article 32. SHOP DRAWINGS

Contractor shall check and verify all field measurements, and shall submit with such promptness as to cause no delay in Contractor’s own work or in that of any other Contractor three (3) copies, checked and approved by Contractor, of all shop or setting drawings, schedules and materials lists required for the work of various trades. Architect/Engineer shall check and approve within ten (10) working days such schedules and drawings only for conformance with design concept of project, and compliance with information given in contract documents. Contractor shall make any corrections required by Architect/Engineer; file with Architect/Engineer three (3) corrected copies, and furnish such other copies as may be needed for construction. Architect/Engineer’s approval of such drawings or schedules shall not relieve Contractor from responsibility for deviations from drawings or specifications unless Contractor has in writing called Architect/Engineer’s attention to such deviations at time of submission and secured Architect/Engineer’s written approval, nor shall it relieve Contractor from responsibility for errors in shop drawings or schedule.

Article 33. SAMPLES

Contractor shall furnish for approval, within ten (10) days following award of contract, all samples as required in specifications together with catalogs and supporting data required by Architect/Engineer. This provision shall not authorize any extension of time for performance of this contract. Architect/Engineer will check and approve such samples, within five (5) working days from receipt of same, only for conformance with design concept of work and for compliance with information given in contract documents. Work shall be in accordance with approved samples.

Article 34. COST BREAKDOWN AND PERIODICAL ESTIMATES

Contractor shall furnish on forms provided by COUNTY:

- (a) Within ten (10) days of award of contract, a detailed estimate giving complete breakdown of contract price.
- (b) A periodical itemized estimate of work done for purpose of making partial payments thereon.
- (c) Within ten (10) days of request by COUNTY, a schedule of estimated monthly payments which shall be due Contractor under the contract.

Values employed in making up any of these schedules will be used only for determining basis of partial payments, and will not be considered as fixing a basis for additions to or deductions from contract price.

Article 35. PAYMENTS

- (a) Each month, within fifteen (15) days after receipt of approved periodical estimate for partial payment, there shall be paid to Contractor a sum equal to ninety-five percent (95%) of value of work performed up to last day of previous month, less aggregate of previous payments. Monthly payments shall be made only on basis of monthly estimates which shall be prepared by Contractor on a form approved by COUNTY and filed before the fifth (5th) day of month during which payment is to be made. Work completed as estimated shall be an estimate only, and no inaccuracy or error in said estimate shall operate to release Contractor or any bondsman from damages arising from such work or from enforcing each and every provision of this contract, and COUNTY shall have the right subsequently to correct any error made in any estimate for payment. Contractor shall not be entitled to have any payment estimates processed or be entitled to have any payment made for work performed so long as any lawful or proper direction concerning work, or any portion thereof given by COUNTY or Architect, shall remain uncomplished with. The final payment of five percent (5%) of the value of work done under this contract, if unencumbered, shall be made thirty-five (35) days after acceptance of work by COUNTY. Acceptance will be made only by action of the Board of Supervisors in session. Acceptance by Contractor of said final payment shall constitute a waiver of all claims against COUNTY arising from this contract. At any time after fifty percent (50%) of the work has been completed, if COUNTY, by action of its governing body, finds that satisfactory progress is being made, COUNTY may make any of the remaining payments in full on actual work completed or may withhold any amount up to five percent (5%) thereof as COUNTY may find appropriate based on the Contractor's progress.
- (b) Contractor may elect to substitute or execute an escrow agreement (in the form prescribed by the Public Contracts Code) in place of retained funds held by COUNTY pursuant to Public Contract Code section 22300.
- (c) COUNTY shall pay interest at the legal rate set forth in Code of Civil Procedure 685.010 in the event payment is not made within thirty (30) days of an undisputed properly submitted request.

Article 36. PAYMENT WITHHELD

In addition to amount which COUNTY may retain under article entitled "Payments," COUNTY may withhold a sufficient amount of amounts of any payment or payments otherwise due to Contractor, as in COUNTY's judgment may be necessary to cover:

- (a) Payments which may be past due and payable for just claims against Contractor or any subcontractors for labor or materials furnished in and about the performance of work on the project under this contract.
- (b) Defective work not remedied.
- (c) Failure of Contractor to make proper payments to subcontractors or for material or labor.
- (d) Completion of contract, if there exists a reasonable doubt that contract can be completed for balance then unpaid.
- (e) Damage to another Contractor.

When the above grounds are removed, payment shall be made for amounts withheld because of them.

COUNTY may apply such withheld amount to payment of such claims or obligations at COUNTY's discretion. In so doing, COUNTY shall be deemed the agent of Contractor, and any payment so made by COUNTY shall be considered as a payment made under contract by COUNTY to Contractor, and COUNTY shall not be liable to Contractor for such payments made in good faith. Such payments may be made without prior judicial determination of claim or obligations. COUNTY will render Contractor a proper accounting of such funds disbursed on behalf of Contractor.

Article 37. CHANGES AND EXTRA WORK

All change orders shall be subject to the Public Contract Code, including but not limited to sections 20137 and 20142, *et seq.*

- (a) Change Orders. Contractor shall make no changes to the Work to be performed pursuant to this Agreement, including but not limited to additions, deletions, modifications or substitutions, nor shall Contractor perform any extra work (collectively, "Change Order Work") without the prior written consent of COUNTY. If Contractor encounters conditions it considers different from those described in Exhibit A to this Agreement, Contractor may request a change order in conformance with COUNTY's standard procedure ("Change Order"). If COUNTY approves the request, Contractor will execute a Change Order and Contractor's execution of the Change Order shall confirm approval thereof. COUNTY may order additional work, and Contractor shall perform such changes in the Work as directed by COUNTY in any Change Order prepared by Contractor. COUNTY's rights to eliminate portions of the Work or to initiate a Change Order shall not be limited in any way. The Change Order shall be in writing and shall include:
- (1) Any and all supporting documents and drawings depicting the source and location of the desired change, and explain in detail the field conditions and reasons for the requested change;
 - (2) Any change or adjustment to the compensation set forth in this Agreement in Article 3 as a result of changes in the Work based on a lump sum or time and material basis, as may be directed by COUNTY; and
 - (3) Any request for adjustments to time for completion of the Project.
- (b) Payment for Change Order Work. Contractor shall not be entitled to receive any compensation for work, labor, materials or changes of any kind, regardless of whether ordered by COUNTY or any of its representatives, unless a Change Order has been submitted in writing and approved prior to the commencement of any Change Order Work as described above. If the changes are required by any inspecting governmental agencies or utility companies, or are otherwise required to comply with any codes, laws, rules or regulations, including those set forth in this Agreement, then Contractor shall not be entitled to any increases in the compensation set forth in this Agreement at Article 3 or other compensation as a result of the changes.
- (c) Disputed Change Order Work. Any dispute concerning the performance of such Change Order Work or the amount of compensation to be paid to Contractor by COUNTY shall not affect Contractor's obligation to perform such Change Order Work. Contractor agrees that it shall timely complete all Change Order Work even if there shall be a dispute between Contractor and COUNTY over the amount or scope of the Change Order Work. Contractor shall have the right to be compensated for any undisputed Change Order Work amounts as determined to be undisputed in COUNTY's sole discretion.
- (d) Authorized Representative. No Change Order shall be valid or binding against COUNTY unless such Change Order has been executed by COUNTY's designated representative, who is the Director of Public Works. COUNTY shall notify Contractor in writing if the designated

representative is changed. The authority to execute a Change Order on this project shall not exceed the amount allowed by law pursuant to Government Code sections 20137-20142, *et seq.*

Article 38. DEDUCTIONS FOR UNCORRECTED WORK

If COUNTY deems it inexpedient to correct work injured or done not in accordance with contract, an equitable deduction from contract price shall be made therefore.

Article 39. PAYMENTS BY CONTRACTOR

Contractor shall pay:

- (a) For all transportation and utility services not later than the twentieth (20th) day of the calendar month following that in which such services are rendered;
- (b) For all materials, tools and other expendable equipment to the extent of ninety-five percent (95%) of cost thereof, not later than the twentieth (20th) day of the calendar month following that in which such materials, tools and equipment are delivered at site of project and balance of cost thereof not later than the thirtieth (30th) day following completion of that part of the work in or on which such materials, tools and equipment are incorporated or used; and
- (c) To each of Contractor's subcontractors, not later than the fifth (5th) day following each payment to Contractor; the respective amounts allowed Contractor on account of work performed by respective subcontractor to the extent of such subcontractor's interest therein.

Article 40. CONTRACTOR'S SUPERVISION

Unless personally present on premises where work is being done, Contractor shall keep on the work, during its progress, a competent superintendent satisfactory to COUNTY.

Contractor represents and warrants that any superintendent, employee, subcontractor and agent who will be performing any of the duties and obligations of Contractor herein possess all required licenses and authorities, as well as the experience, training, and communication skills to perform such tasks and communicate with the COUNTY and its representatives.

Superintendent shall not be changed except with consent of COUNTY unless superintendent proves to be unsatisfactory to Contractor and ceases to be in his employ. Superintendent shall represent Contractor in Contractor's absence, and all directions given to superintendent shall be as binding as if given to Contractor. Other directions shall be so confirmed in written request in each case.

Contractor shall give efficient supervision to work, using Contractor's best skill and attention. Contractor shall carefully study and compare all drawings, specifications and other instructions, and shall at once report to Architect/Engineer any error, inconsistency or omission which Contractor may discover.

Article 41. INSPECTOR'S FIELD OFFICE

Contractor shall provide for use of COUNTY and its representative during construction working hours a temporary office of not less than seventy-five (75) square feet of floor area to be located as directed by COUNTY and its representative and to be maintained until removal is authorized by COUNTY and its representative. Office shall be of substantial waterproof construction with adequate natural light and ventilation by means of stock design windows. Door shall have a key, type walk, or padlock hasp.

A table satisfactory for study of plans and two chairs shall be provided by Contractor. Contractor shall provide and pay for adequate electric lights, local telephone service, and adequate air conditioning and heating for the field office until authorized removal.

Article 42. DOCUMENTS ON WORK

Contractor shall keep one copy of all contract documents, including addenda and change orders which are a part of contract documents, on job at all times. Said documents shall be kept in good order and available to Architect/Engineer representatives. Contractor shall be acquainted with and comply with all California Administrative Code provisions relating to this project, including, but not limited to, Title 19.

Article 43. UTILITIES AND RELOCATION

(a) All utilities, including, but not limited to, electricity, water, gas and telephone used on work, shall be furnished and paid for by Contractor. Contractor shall furnish and install necessary temporary distribution systems, including meters if necessary, from distribution points to points on site where utility is necessary to carry on the work. Upon completion of work, Contractor shall remove all temporary systems.

If contract is for addition to existing facility, Contractor may, with written permission of COUNTY, use COUNTY's existing utilities by making prearranged payments to COUNTY for utilities used by Contractor for construction.

(b) Contractor shall not be assessed damages for delay in completion of the project when such delay was caused by the failure of the awarding authority of this contract or the owner of the utility to provide for removal or relocation of the existing main or trunkline utility facilities; however, when the Contractor is aware that removal or relocation of an existing utility has not been provided for, Contractor shall promptly notify the awarding authority and the utility in writing, so that provision for such removal or relocation may be made to avoid and minimize any delay which might be caused by the failure to remove or relocate the main or trunk line utility facilities, or to provide for its removal or relocation.

In accordance with section 4215 of the Government Code, if the Contractor, while performing the contract, discovers any existing main or trunkline utility facilities not identified by the public agency in the contract plans or specifications, Contractor shall immediately notify the public agency and utility in writing. The public utility, where they are the owner, shall have the sole discretion to perform repairs or relocation work at a reasonable price. The Contractor shall be compensated for the costs of locating and repairing damage not due to the failure of the Contractor to exercise reasonable care, and removing or relocating such utility facilities not indicated in the plans and specification with reasonable accuracy and for equipment on the project necessarily idled during such work. Such compensation shall be in accordance with the extra work provisions set out at Article 37 hereof.

Article 44. SANITARY FACILITIES

Contractor shall provide a sanitary, temporary, portable toilet facility as directed by the COUNTY and its representative for the use of all workers. The building shall be maintained in a sanitary condition at all times, and shall be left at the site until removal is directed by the COUNTY and its representative.

Article 45. TRENCHES

(a) Trenching Requirements – Four Feet (4') Below the Surface. In the event the Project involves digging trenches or other excavations that extend deeper than four feet (4') below the surface, Contractor shall:

(1) Promptly, and before the following conditions are disturbed, notify COUNTY, in writing, of any:

- (A) Material that Contractor believes may be material that is hazardous waste, as defined in Health & Safety Code section 25117, that is required to be removed to a Class I, Class II, or Class III disposal site in accordance with provisions of existing law;
 - (B) Subsurface or latent physical conditions at the site differing from those indicated by information about the site made available to bidders prior to the deadline for submitting bids; and
 - (C) Unknown physical conditions at the site of any unusual nature, different materially from those ordinarily encountered and generally recognized as inherent in work of the character provided for in the Agreement.
- (2) In response to any written notice generated pursuant to paragraph (a) above, COUNTY shall promptly investigate the conditions, and if it finds that the conditions do materially so differ, or do involve hazardous waste, and cause a decrease or increase in Contractor's cost of, or the time required for, performance of any part of the Work, shall issue a change order under the procedures described in paragraph 37 of the General Conditions.
- (3) In the event that a dispute arises between COUNTY and Contractor whether the conditions materially differ, or involve hazardous waste, or cause a decrease or increase in Contractor's cost of, or time required for, performance of any part of the Work, Contractor shall not be excused from any scheduled completion date provided for by this Agreement, but shall proceed with all Work to be performed under this Agreement. Contractor shall retain any and all rights provided either by contract or by law which pertain to the resolution of disputes and protests between the Parties.
- (b) Trenching Requirements – Project in Excess of Twenty-Five Thousand Dollars (\$25,000) and Five Feet (5') Below the Surface. For projects involving both an estimated expenditure in excess of twenty-five thousand dollars (\$25,000) and the excavation of any trench five feet (5') or more in depth, Contractor shall submit a detailed plan showing the design of shoring, bracing, sloping or other provisions to be made for worker protection from the hazard of caving ground during the excavation of such trench. The plan must be accepted by COUNTY (or by a registered civil or structural engineer, employed by COUNTY, to whom authority to accept has been delegated) in advance of excavation. If such plan varies from the shoring system standards, the plan shall be prepared by a registered civil or structural engineer. Nothing in this paragraph shall allow Contractor to use a shoring, sloping, or protective system less effective than that required by California Construction Safety Orders. Further, nothing in this paragraph shall be construed to impose tort liability on COUNTY or any of its employees.

Article 46. PROTECTION OF WORK AND PROPERTY

Contractor shall be responsible for all damages to persons or property that occur as a result of Contractor's fault or negligence in connection with the prosecution of this contract, and shall be responsible for the proper care and protection of all materials delivered and work performed until completion and final acceptance by COUNTY. All work shall be solely at Contractor's risk. Contractor shall adequately protect adjacent property from settlement or loss of lateral support as provided by law and contract documents. Contractor shall take all necessary precautions for safety of employees on the work, and shall comply with all applicable safety laws and building codes to prevent accidents or injury to persons on; about or adjacent to premises where work is being performed. Contractor shall erect and properly maintain, at all times, as required by conditions and progress of work, all necessary safeguards, signs, barriers, lights and watchmen for protection of

workers and the public, and shall post danger signs warning against hazards created by such features in the course of construction. Contractor shall designate a responsible member of its organization on the work, whose duty shall be prevention of accidents. Name and position of person so designated shall be reported to COUNTY by Contractor.

In an emergency affecting safety of life or of work or of adjoining property, Contractor, without special instruction or authorization from COUNTY and its representative, is hereby permitted to act, at Contractor's discretion, to prevent such threatened loss or injury, and Contractor shall so act, without appeal, if so authorized or instructed by COUNTY and its representative. Any compensation claimed by Contractor on account of emergency work shall be determined by agreement.

Contractor shall provide such heat, covering, and enclosures as are necessary to protect all work, materials, equipment, appliances, and tools against damage by weather conditions. Contractor shall take adequate precautions to protect existing sidewalks, curbs, pavements, utilities, adjoining property and structures, and to avoid damage thereto, and repair any damage thereto caused by construction operations.

Contractor shall:

Enclose working area with a substantial dust reducing barrier and public safety barricade, and arrange work to cause minimum amount of inconvenience to public and COUNTY Staff in their regular business activities.

Provide substantial barricades around any shrubs or trees indicated to be preserved.

Deliver materials to building area over route designated by Architect.

When directed by COUNTY, take preventative measures to eliminate objectionable dust.

Confine Contractor's apparatus, the storage of materials, and the operations of workers to limits indicated by law, ordinances, permits or directions of Architect, and shall not unreasonably encumber premises with materials, and enforce all instructions of COUNTY and Architect regarding signs, advertising, fires, danger signals, barricades and smoking, and require that all persons employed on work comply with all regulations while on construction site. Hazardous materials of any kind are not allowed on site, without prior written approval from COUNTY.

Take care to prevent disturbing or covering any survey markers, monuments, or other devices marking property boundaries or corners. If such markers are disturbed by accident, they shall be replaced by an approved civil engineer at no cost to COUNTY.

Article 47. LAY OUT AND FIELD ENGINEERING

All field engineering required for laying out Contractor's work and establishing grades for earthwork operations shall be furnished by Contractor at Contractor's expenses. Such work shall be done by a qualified civil engineer approved by Architect/Engineer. Any required "As-Built" drawings of site development shall be prepared by the approved civil engineer.

Article 48. CUTTING AND PATCHING

Contractor shall do all cutting, fitting, or patching of work as required to make its several parts come together properly and fit it to receive or received by work of other Contractors showing upon, or reasonably implied by, the drawings and specifications for the completed structure, and Contractor shall make good after them as Architect/Engineer may direct. Contractor shall not endanger any

work by cutting, excavating or otherwise altering work, and shall not cut or alter work of any other Contractor save with consent of Architect/Engineer.

Article 49. CLEANING UP

Contractor at all times shall keep premises free from debris such as waste, rubbish, and excess materials and equipment caused by work; debris shall be removed from premises. Contractor shall not leave debris under, in or about the premises. Upon completion of work, Contractor shall clean any areas where debris has collected. Contractor shall remove temporary fencing, barricades, and any temporary facilities from site.

Article 50. CORRECTION OF WORK

Contractor shall promptly remove from premises all work determined by COUNTY as failing to conform to contract, whether incorporated or not. Contractor shall promptly replace and re-execute his own work to comply with contract documents without additional expense to COUNTY, and shall bear the expense of making good all work of other Contractors destroyed or damaged by such removal or replacement.

If Contractor does not remove such work and materials within a reasonable time, fixed by written notice, COUNTY may remove the work and materials and may store the material at Contractor's expense. If Contractor does not pay expenses of such removal within ten (10) days' time thereafter, COUNTY may liquidate such work and materials upon private sale, and shall account for net proceeds thereof, after deducting all costs and expenses that should have been borne by Contractor.

Article 51. ACCESS TO WORK

COUNTY and its representative shall at all times have access to work wherever it is in preparation or progress. Contractor shall provide safe and proper facilities for such access so that COUNTY's representative may perform their functions under contract.

Article 52. OCCUPANCY

COUNTY reserves the right to occupy buildings at any time before completion, and such occupancy shall not constitute final acceptance of any part of work covered by this contract.

Article 53. COUNTY'S INSPECTOR

COUNTY may assign a representative to oversee work. Such representative shall have access to Inspector's Field Office and shall be fully informed of all progress and manner of work and character of materials. Representative shall have authority to stop work whenever provisions of the contract documents are not being complied with and Contractor shall instruct Contractor's employees accordingly.

All work shall be under observation of said COUNTY and its representative. Such personnel shall have free access to any or all parts of work at any time. Contractor shall furnish COUNTY and its representative reasonable facilities "Inspector's Field Office" for obtaining such information as may be necessary to keep COUNTY and its representative fully informed respecting progress and manner of work and character of materials. Inspection of work shall not relieve Contractor from any obligation to fulfill Contractor's contract. COUNTY and its representative shall have authority to stop work whenever provisions of contract documents are not being complied with, and Contractor shall instruct Contractor's employees accordingly.

Article 54. TESTS AND INSPECTIONS

If contract, COUNTY's instructions, laws, ordinances or any public authority require any work to be specially tested or approved, Contractor shall give notice in accordance with such authority of its readiness for observation or inspection at least two (2) working days prior to being tested or

covered up. If inspection is by authority other than COUNTY, Contractor shall inform COUNTY of the date fixed for such inspection. Required certificates of inspection shall be secured by Contractor. Observations by COUNTY, its representative and other public authority shall be promptly made, and where practicable, at source of supply. If any work should be covered up without approval or consent of COUNTY, its representative and public authority, it must, if required by COUNTY, its representative and public authority, be uncovered for examination and satisfactorily reconstruction at Contractor's expenses in compliance with contract.

Costs of tests of any material found to be not in compliance with contract shall be paid for by Contractor.

See Comprehensive Specifications for materials to be tested.

Where such inspection and testing are to be conducted by an independent laboratory or agency, such materials or samples of materials to be tested shall be selected by such laboratory or agency or COUNTY's representative, and not by Contractor.

Contractor shall notify COUNTY a sufficient time in advance of manufacture of materials to be supplied by Contractor under contract which must by terms of contract be tested, in order that COUNTY may arrange for testing of same at source of supply. Any materials shipped by Contractor from source of supply prior to having satisfactorily passed such testing and inspection, or prior to receipt of notice from said representative that such testing and inspection will not be required, shall not be incorporated in work without prior approval of COUNTY and subsequent testing and inspection.

Re-examination of questioned work may be ordered by COUNTY, and, if so ordered, work must be uncovered by Contractor. If such work be found in accordance with contract documents, COUNTY shall pay costs of re-examination and replacement. If such work be found not in accordance with contract documents, Contractor shall pay such costs.

Article 55. SOILS INVESTIGATION REPORT

When a soils investigation report obtained from test holes in site is available, such report shall not be part of this contract. Any information obtained from such report or any information given on drawings as to subsurface soil condition or to elevations of existing grades or elevations of underlying rock is approximate only and is not guaranteed, and does not form a part of the contract. Contractor is required to make a visual examination of site, and must make whatever tests Contractor deems appropriate to determine underground condition of soil. Contractor agrees that it will make no claim against COUNTY for damages in the event that, during progress of the work, Contractor encounters subsurface or latent conditions at site materially differing from those shown on drawings or indicated in specifications, or for unknown conditions of an unusual nature which differ materially from those ordinarily encountered and generally recognized as inherent in the work of the character provided for in plans and specifications.

Article 56. ARCHITECT/ENGINEER'S AND CONSTRUCTION MANAGER'S STATUS

The construction manager shall be COUNTY's representative during the construction period, and shall observe the progress and quality of the work on behalf of COUNTY. The construction manager shall have the authority to act on behalf of COUNTY only to the extent expressly provided in the contract documents. The construction manager shall have authority to stop work whenever such stoppage may be necessary in construction manager's reasonable opinion to insure the proper execution of the contracts.

The Architect/Engineer shall be, in the first instance, the judge of compliance with the design intent of the contract documents.

Article 57. INDEMNITIES

- (a) Contractor agrees to the fullest extent permitted by law to indemnify, defend, protect, and hold COUNTY and its representatives, officers, directors, designees, employees, agents, successors, and assigns harmless from any and all claims, expenses, liabilities, causes of action, demands, losses, penalties, attorneys fees and costs, in law or equity, of every kind and nature whatsoever arising out of or in connection with Contractor's negligent acts and omissions or willful misconduct under this Agreement ("Claims"), whether or not arising from the passive negligence of COUNTY, but does not include Claims that are finally determined to be the result of the sole negligence or willful misconduct of COUNTY.

- (b) Contractor agrees to defend with counsel acceptable to COUNTY, indemnify and hold COUNTY harmless from all Claims, including but not limited to:
 - (1) Personal injury, including but not limited to bodily injury, emotional injury, sickness or disease or death to persons including but not limited to COUNTY's representatives, officers, directors, designees, employees, agents, successors and assigns, subcontractors and other third parties and/or damage to property of anyone (including loss of use thereof) arising out of Contractor's negligent performance of, or willful misconduct surrounding, any of the terms contained in this Agreement, or anyone directly or indirectly employed by Contractor or anyone for whose acts Contractor may be liable;
 - (2) Liability arising from injuries to Contractor and/or any of Contractor's employees or agents arising out of Contractor's negligent performance of, or willful misconduct surrounding, any of the terms contained in this Agreement, or anyone directly or indirectly employed by Contractor or anyone for whose acts Contractor may be liable;
 - (3) Penalties imposed upon account of the violation of any law, order, citation, rule, regulation, standard, ordinance or statute caused by the negligent action or inaction, or willful misconduct of Contractor or anyone directly or indirectly employed by Contractor or anyone for whose acts Contractor may be liable;
 - (4) Infringement of any patent rights which may be brought against COUNTY arising out of Contractor's work;
 - (5) Any violation or infraction by Contractor of any law, order, citation, rule, regulation, standard, ordinance or statute in any way relating to the occupational health or safety of employees; and
 - (6) Any breach by Contractor of the terms, requirements or covenants of this Agreement.

- (c) The indemnification provisions of Paragraphs 57(b)(1) through 57(b)(6) above shall extend to Claims occurring after this Agreement is terminated, as well as while it is in force.

Article 58. PROVISIONS REQUIRED BY LAW DEEMED INSERTED

Each and every provision of law and clause required by law to be inserted in the contract shall be deemed to be inserted herein, and the contract shall be read and enforced as though it were included herein, and if, through mistake or otherwise, any such provision is not inserted, or is not correctly inserted, then upon application of either party, the contract shall forthwith be physically amended to make such insertion or correction.

Article 59. LABOR - EMPLOYMENT SAFETY

Contractor shall maintain emergency first aid treatment for Contractor's employees which complies with the Federal Occupational Safety and Health Act of 1970 (29 U.S.C.A. 651, *et seq.*).

Article 60. NOTICE OF TAXABLE POSSESSORY INTEREST

The terms of this document may result in the creation of a possessory interest. If such a possessory interest is vested in a private party to this document, the private party may be subjected to the payment of personal property taxes levied on such interest.

Article 61. ASSIGNMENT OF UNFAIR BUSINESS PRACTICES CLAIMS (CLAYTON ACT AND CARTWRIGHT ACT)

Bidder shall comply with the following:

“In entering into a public works contract or a subcontract to supply goods, services or materials pursuant to a public works contract, the contractor or subcontractor offers and agrees to assign to the awarding body all rights, title and interest in and to all causes of action it may have under Section 4 of the Clayton Act (15 U.S.C. sec. 15) or under the Cartwright Act (Chapter 2 commencing with Section 16700) of Part 2 of Division 7 of the Business and Professions Code), arising from purchases of goods, services, or materials pursuant to the public works contract or the subcontract. This assignment shall be made and become effective at the time the awarding body tenders final payment to the contractor, without further acknowledgment by the parties.” Cal Pub Contract Code § 7103.5(b)

Article 62. SUBSTITUTION OF SECURITY

Upon Contractor’s request, COUNTY will make payment of funds withheld from progress payments to ensure performance under the contract pursuant to the requirements of California Public Contracts Code, section 22300, if the Contractor deposits in escrow with COUNTY, or with a bank acceptable to COUNTY, securities eligible for investment under Government Code section 16430 or bank savings and loan certificates of deposit, subject to the following conditions:

- (a) Contractor shall bear the expense of COUNTY and the escrow agent, and COUNTY and the bank, in connection with the escrow deposit made.
- (b) Securities or certificates of deposit to be placed in escrow shall be of a value at least equivalent to the amount of retention to be paid to the Contractor pursuant to this Article.
- (c) Contractor shall enter into an escrow agreement satisfactory to COUNTY, which agreement shall include provisions governing, inter alias:
 - (1) The amount of securities to be deposited,
 - (2) The providing of powers of attorney or other documents necessary for the transfer of the securities to be deposited,
 - (3) conversion of cash to provide funds to meet defaults by Contractor including, but not limited to, termination of Contractor’s control over the work, stop notice filed pursuant to law or other amounts to be kept or retained under the provisions of the contract,
 - (4) decrease in value of securities on deposit,
 - (5) The termination of the escrow upon completion of the contract.
- (d) Contractor shall obtain the written consent of the surety to such agreement.

Article 63. NON-DISCRIMINATION AND DISADVANTAGED BUSINESS ENTERPRISE PROGRAM

- (a) During the performance of this Agreement, Contractor and its subcontractors shall not unlawfully discriminate, harass or allow harassment against any employee or applicant for employment because of sex, race, color, ancestry, religious creed, national origin, physical disability (including HIV and AIDS), mental disability, medical condition (cancer), age (over forty (40)), marital status and denial of family care leave. Contractor and its subcontractors

shall insure that the evaluation and treatment of their employees and applicants for employment are free from such discrimination and harassment. Contractor and its subcontractors shall comply with the provisions of the Fair Employment and Housing Act (Gov. Code section 12990 (a-f) *et seq.*) and the applicable regulations promulgated thereunder (California Code of Regulations, Title 2, section 7285 *et seq.*). The applicable regulations of the Fair Employment and Housing Commission implementing Government Code section 12990 (a-f), set forth in Chapter 5 of Division 4 of Title 2 of the California Code of Regulations, are incorporated into this Agreement by reference and made a part hereof as if set forth in full. The applicable regulations of Section 504 of the Rehabilitation Act of 1973 (29 U.S.C. section 794 (a)) are incorporated into this Agreement by reference and made a part hereof as if set forth in full. Contractor and its subcontractors shall give written notice of their obligations under this clause to labor organizations with which they have a collective bargaining or other agreement. Contractor shall include the nondiscrimination and compliance provisions of this clause in all subcontracts to perform Work under this Agreement.

- (b) Contractor and its subcontractors shall reference and abide by the guidance and Disadvantaged Business Enterprise specifications contained in the California Department of Transportation's Local Programs Procedures 06-01 (which has been approved and released at <http://www.dot.ca.gov/>) when working pursuant to this Agreement.

Article 64. SPECIAL CONDITIONS

- (a) The work shall be commenced on the date stated in COUNTY's *Notice to the Contractor to Proceed* which date will be not greater than ten (10) consecutive calendar days from and after the date of execution of the contract, and shall be completed within **sixty-five (65) working days** from and after the date stated in such notice. (See Article 2 of *Agreement* and Article 6 of *General Conditions*.)
- (b) The number of copies of drawings and specifications to be furnished to Contractor free of charge, per Article 3 of the *General Conditions* is three (3).
- (c) The number of executed copies of the *Agreement*, the *Performance Bond*, and the *Payment Bond* for the *Public Works* required is six (6).

Article 65. CONTRACT CONSTRUCTION

This contract has been reviewed by legal counsel for both COUNTY and Contractor, and no presumption or rule that ambiguities shall be construed against the drafting party shall apply to the interpretation or enforcement of this contract and/or any and all amendments thereto.

Article 66. COGNIZANCE OF VIOLATIONS BY COUNTY

- (a) Contractor understands and agrees that COUNTY shall take cognizance of violations of Chapter 1 of Part 7 of Division 2 of the California Labor Code committed in the course of the execution of this Agreement, and shall promptly report any suspected violations to the Labor Commissioner.
- (b) If COUNTY determines as a result of its own investigation that there has been a violation of Chapter 1 of Part 7 of Division 2 of the California Labor Code and withholds payment to Contractor, the procedures in California Labor Code section 1771.6 shall be followed.
- (c) COUNTY may bring an action in a court of competent jurisdiction to recover from Contractor the difference between the wages actually paid to an employee and the wages that were required to be paid to an employee pursuant to Chapter 1 of Part 7 of Division 2 of the California Labor Code, any penalties required to be paid pursuant to Chapter 1 of Part 7 of Division 2 of the California Labor Code, and costs and attorney's fees related to the action, if either of the following is true:

- (1) COUNTY previously affirmatively represented to Contractor in writing, in the call for bids, or otherwise, that the Work was not a “public work,” as defined in Chapter 1 of Part 7 of Division 2 of the California Labor Code; or
- (2) COUNTY received actual written notice from the Department of Industrial Relations that the Work is a “public work,” as defined in Chapter 1 of Part 7 of Division 2 of the California Labor Code, and failed to disclose that information to Contractor before the bid opening or award.

Article 67. LABOR STANDARDS COMPLIANCE REQUIREMENTS

- (a) It is Contractor’s responsibility to provide all labor compliance documentation from its subcontractors completely and accurately in a timely manner. Contractor is responsible to review promptly and then forward on all required documentation to COUNTY per the time schedules in the Labor Compliance Handout. Included with the Labor Compliance Handout, COUNTY will provide training, documentation requirements, forms, etc., at the preconstruction conference or at a time designated by COUNTY.

For those Public Works Projects that are subject to the State Department of Industrial Relations (DIR), Division of Labor Standards Enforcement (DLSE) compliance monitoring and enforcement it is the Contractor’s responsibility to submit certified payroll records directly to the state Compliance Monitoring Unit (CMU). More information concerning state compliance can be found at <http://www.dir.ca.gov/dlse/cmucmu.html>. The responsibility for compliance with these provisions is fixed with the Contractor.

- (b) In the event, during the review process of labor compliance documentation from COUNTY’s labor compliance monitor, inaccurate, missing or incomplete information was provided, the labor compliance monitor will request from Contractor the items, revisions and documentation needed. The cost of this additional labor compliance enforcement shall be borne by Contractor.

Article 68. CONFLICT OF INTEREST AND GRATUITIES

- (a) Contractor agrees that it presently has no interest and shall not acquire any interest, direct or indirect, which could conflict in any manner or degree with the performance of services required to be performed under this Agreement. Contractor further agrees that in the performance of this Agreement, no person having any such interest shall be employed.
- (b) Contractor agrees to designate such person or persons who have responsibility for carrying out the services under this Agreement and that such person or persons as may be designated shall take any and all actions necessary to comply with COUNTY’s Conflict of Interest Code adopted pursuant to California Government Code section 81000 to the extent required thereunder.
- (c) If it is found, after notice and hearing by COUNTY, that gratuities (in the form of entertainment, gifts, or otherwise) were offered or given by Contractor, or any agent or representative of Contractor, to any officer, employee or agent of COUNTY with a view toward securing a contract or securing favorable treatment with respect to the awarding or amending or the making of any determinations with respect to the performance of this Agreement, COUNTY may, by written notice to Contractor, terminate the right of Contractor to proceed under this Agreement and/or may pursue such other rights and remedies provided by law or under this Agreement.
- (d) In the event this Agreement is terminated as provided herein, COUNTY shall be entitled (1) to pursue the same remedies against Contractor as it could pursue in the event of a breach

of the Agreement by Contractor, and (2) as a penalty in addition to any other damages to which it may be entitled by law, to exemplary damages in an amount (as determined by COUNTY) which shall be not less than three (3) nor more than ten (10) times the costs incurred by Contractor in providing any such gratuities to any such officer, employee or agent.

Article 69. FEDERAL CONTRACT REQUIREMENTS

(a) Signage Requirements.

- (1) Project Identity Signage. Contractor is required to provide and install the required project identity signage as detailed in the Plans and Specifications, in the size and at the location indicated by the Director of Public Works or his/her designee, and to maintain the signage in good condition for the duration of the Project. The signage may not be removed until the Notice of Completion is recorded or by written direction of the Director of Public Works or his/her designee.
- (2) Required Employee Signage and Posters. Contractor is required to provide and install the Federal and State required employee posters and the required material pertaining to the required labor standards provisions are posted (including, but not limited to, WH-1321, OSHA 3165 and OFCCP-English, EFCCP-Spanish) at the worksite in a prominent and accessible place.
- (3) Section 3 Compliant Signage. If required by COUNTY, Contractor is directed to provide and install the "Offer for Employment" signage as detailed in the Plans and Specifications in the size and at the location indicated by the Director of Public Works or his/her designee and to maintain the signage in good condition for the duration of the Project. The signage may not be removed until the Notice of Completion is recorded or by written direction of the Director of Public Works or his/her designee.

(b) Housing And Urban Development Act Compliance. When applicable, Contractor agrees to comply with Section 3 of the Housing and Urban Development Act of 1968 (42 U.S.C. 3601 *et seq.*) which provides that to the greatest extent feasible, Contractor shall provide job training, employment and contracting opportunities for low- or very-low income residents in connection with the Project. The responsibility for compliance with these provisions is fixed with Contractor.

(c) Copeland "Anti-Kickback" Act Compliance. When applicable, Contractor agrees to comply with the Copeland Act (18 USC §874 and 40 USC §276c; 29 CFR Part 3) which precludes Contractor and its subcontractors from in any way inducing an employee to give up any part of the compensation to which he or she is entitled under his or her contract of employment. Contractor and its subcontractors shall submit a weekly statement of the wages paid to each employee performing on covered work during the preceding payroll period. Contractor understands and agrees that should Contractor its subcontractors induce an employee working on a covered contract to give up any part of the compensation to which he or she is entitled, the inducing party may be subject to a five thousand dollar (\$5,000) fine, or imprisonment for up to five (5) years, or both. Contractor also understands and agrees that willful falsification of the statement of compliance may subject the employer to civil or criminal prosecution and may be cause for contract termination or debarment. The responsibility for compliance with these provisions is fixed with Contractor.

(d) Fair Labor Standards Act Compliance. When applicable, Contractor agrees to comply with the Fair Labor Standards Act of 1938 as amended (29 U.S.C. 201 *et seq.*) which establishes minimum wage, overtime pay, recordkeeping, and youth employment standards affecting full-time and part-time workers on the Project. The responsibility for compliance with these provisions is fixed with Contractor.

- (e) Certification Regarding Debarment, Suspension and Other Responsibility Matters. When applicable, Contractor agrees to execute a certification regarding debarment, suspension and other responsibility matters. The responsibility for compliance with this provision is fixed with Contractor.
- (f) Federal Equal Employment Opportunity Construction Contract Specifications. When applicable, Contractor agrees to incorporate the notice set forth in paragraph (d) of 41 C.F.R. 60-4.2 relating to the "Equal Opportunity Clause" and the "Standard Federal Equal Employment Specifications." The responsibility for compliance with this provision is fixed with Contractor.
- (g) Clean Air Act and the Federal Water Pollution Control Act. When applicable, Contractor agrees to comply with all applicable standards, orders or regulations issued pursuant to the Clean Air Act (42 U.S.C. 7401 *et seq.*), the Federal Water Pollution Control Act as amended (33 U.S.C. 1251 *et seq.*), Presidential Executive Order 11738 and Environmental Protection Agency regulations set forth at 40 C.F.R. Part 15. Contractor understands and agrees that violations shall be reported to the Federal awarding agency and the Regional Office of the Environmental Protection Agency. The responsibility for compliance with these provisions is fixed with Contractor.
- (h) Prohibition on the Use of Federal Funds for Lobbying. When applicable, Contractor shall file the required certification. Each tier certifies to the tier above that it will not and has not used Federal appropriated funds to pay any person or organization for influencing or attempting to influence an officer or employee of any agency, a member of Congress, officer or employee of Congress, or an employee of a member of Congress in connection with obtaining any Federal contract, grant or any other award covered by 31 U.S.C. 1352. Each tier shall also disclose any lobbying with non-Federal funds that takes place in connection with obtaining any Federal award. Such disclosures are forwarded from tier to tier up to the recipient. The responsibility for compliance with this provision is fixed with Contractor.
 - (1) Federal Employment Eligibility Verification. Contractor shall verify name, date of birth and social security number, along with immigration information for non-citizens in order to verify the identity and employment eligibility of both citizen and non-citizen new hires. The responsibility for compliance with this provision is fixed with Contractor.
 - (2) The Civil Rights, HCD and Age Discrimination Act Assurances. During the performance of this Agreement, Contractor assures that no otherwise qualified person shall be excluded from participation or employment, denied program benefits or be subjected to discrimination based on race, color, national origin, gender, age or handicap, under any program or activity funded by this Agreement, as required by Title VI of the Civil Rights Act of 1964, Title I of the Housing and Community Development Act of 1974, as amended, and the Age Discrimination Act of 1975, and all implementing regulations. The responsibility for compliance with these provisions is fixed with Contractor.
- (k) Standard Equal Opportunity Clause.
 - (1) Contractor hereby agrees that it will incorporate or cause to be incorporated into any contract for construction work, or modification thereof, as defined in the regulations of the Secretary of Labor at 41 CFR Chapter 60, which is paid for in whole or in part with funds obtained from the Federal Government or borrowed on the credit of the Federal Government pursuant to a grant, contract, loan insurance, or guarantee, or undertaken pursuant to any Federal program involving such grant, contract, loan, insurance, or guarantee, the following equal opportunity clause:

“During the performance of this contract, the Contractor agrees as follows:

1. “The Contractor will not discriminate against any employee or applicant for employment because of race, color, religion, sex, national origin or disabilities. The Contractor will take affirmative action to ensure that applicants are employed, and that employees are treated during employment without regard to their race, color, religion, sex, or national origin. Such action shall include, but not be limited to, the following: employment, upgrading, demotion or transfer; recruitment or recruitment advertising; layoff or termination; rates of pay or other forms of compensation; and selection for training, including apprenticeship. The Contractor agrees to post in conspicuous places, available to employees and applicants for employment, notices to be provided setting forth the provisions of this nondiscrimination clause.
2. “The Contractor will, in all solicitations or advertisements for employees placed by or on behalf of the Contractor, state that all qualified applicants will receive consideration for employment without regard to race, color, religion, sex, national origin or disabilities.
3. “The Contractor will send to each labor union or representative of workers with which the Contractor has a collective bargaining agreement or other contract or understanding, a notice to be provided advising the said labor union or workers’ representatives of the Contractor’s commitments under this section, and shall post copies of the notice in conspicuous places available to employees and applicants for employment.
4. “The Contractor will comply with all provisions of Executive Order 11246 of September 24, 1965, and of the rules, regulations, and relevant orders of the Secretary of Labor.
5. “The Contractor will furnish all information and reports required by Executive Order 11246 of September 24, 1965, and by rules, regulations, and orders of the Secretary of Labor, or pursuant thereto, and will permit access to its books, records, and accounts by the administering agency and the Secretary of Labor for purposes of investigation to ascertain compliance with such rules, regulations, and orders.
6. “In the event of the Contractor’s noncompliance with the discrimination clauses of this contract or with any of the said rules, regulations, or orders, this contract may be canceled, terminated, or suspended in whole or in part and the Contractor may be declared ineligible for further government contracts or federally assisted construction contracts in accordance with procedures authorized in Executive Order 11246 of September 24, 1965, and such other sanctions may be imposed and remedies invoked as provided in Executive Order 11246 of September 24, 1965, or by rules, regulations, or orders of the Secretary of Labor, or as otherwise provided by law.
7. “The Contractor will include the portion of the sentence immediately preceding paragraph “1” and the provisions of paragraphs “1” through “7” in every contract or purchase order unless exempted by rules, regulations, or orders of the Secretary of Labor issued pursuant to Section 504 of Executive Order 11246 of September 24, 1965, so that such provisions will be binding upon each contractor or vendor. The Contractor will take such action with respect to any contract or purchase order as the administering agency may direct as a means of enforcing such provisions, including sanctions for noncompliance; provided,

however, that in the event a Contractor becomes involved in, or is threatened with, litigation with a contractor or vendor as a result of such direction by the administering agency, the Contractor may request the United States to enter into such litigation to protect the interests of the United States.”

- (2) Contractor further agrees that it will be bound by the above equal opportunity clause with respect to its own employment practices when it participates in federally-assisted construction work; provided that if Contractor so participating is a State or local government, the above equal opportunity clause is not applicable to any agency, instrumentality, or subdivision of such government which does not participate in work on or under the Agreement.
- (3) Contractor agrees that it will assist and cooperate actively with the administering agency and the Secretary of Labor in obtaining the compliance of Contractors and subcontractors with the equal opportunity clause and the rules, regulations, and relevant orders of the Secretary of Labor, that it will furnish the Department and HUD and the Secretary of Labor such information as they may require for the supervision of such compliance, and that it will otherwise assist the administering agency in the discharge of the agency’s primary responsibility for securing compliance.
- (4) Contractor further agrees that it will refrain from entering into any contract or contract modification subject to Executive Order 11246 of September 24, 1965, with a contractor debarred from, or who has not demonstrated eligibility for, government contracts and federally-assisted construction contracts, pursuant to the Executive Order and will carry out such sanctions and penalties for violation of the equal opportunity clause as may be imposed upon contractors and subcontractors by the administering agency or the Secretary of Labor pursuant to Part II, Subpart D of the Executive Order. In addition, Contractor agrees that if it fails or refuses to comply with these undertakings, COUNTY may take any or all of the following actions: Cancel, terminate, or suspend in whole or in part this funding commitment (contract, loan, grant, insurance, guarantee); refrain from extending any further assistance to the applicant under the program with respect to which the failure or refund occurred until satisfactory assurance of future compliance has been received from such Contractor; and refer the case to the Department of Justice for appropriate legal proceedings.

Article 70. INELIGIBILITY

If the Bidder has been deemed ineligible to perform work on public works projects pursuant to Labor Code Sections 1777.1 or 1777.7, then it shall be prohibited from bidding on, being awarded a contract for, or performing work as a subcontractor in this project, or any other public works project within the state of California.

Article 71. RESOLUTION OF CLAIMS

- (1) Compliance with all change order procedures is a prerequisite to filing a Public Contract Code Claim pursuant to this Section. Claims must be submitted no later than (a) 30 days after the dispute resolution process set forth in these General Conditions is complete or (b) 30 days after the occurrence of the event giving rise to the claim.
- (2) In accordance with the procedures set forth in Public Contract Code Sections 9204 and 20104-20104.6, a Contractor may submit a claim by registered or certified mail with return receipt requested for one or more of the following: (a) a time extension, including, without limitation, for relief from damages or penalties for delay assessed by the County; (b) payment by the County of money or damages arising from work done by, or on behalf of, the Contractor pursuant to this contract and payment for which is not otherwise expressly provided or to which the Contractor is not otherwise entitled; or (c) payment of an amount that is disputed by the County.

- (3) The Contractor shall furnish reasonable documentation to support the claim, including, but not limited to: 1) a clear concise recital of the basis upon which the claim is asserted, including a designation of the provisions of the Contract upon which the claim is based. 2) a statement as to the amount of time and/or compensation sought pursuant to the claim; 3) whether the Contractor's claim arises from an ongoing occurrence, and if so a description of the specific work activities affected by the claim, 4) a time impact analysis in the event that Contractor request a time extension, 5) full and complete cost records supporting the amount of any claim for additional compensation, and 6) a notarized certification by the Contractor as follows: "Under the penalty of law for perjury or falsification and with specific reference to the California False Claims Act. Government Code Section 12650 et seq. The undersigned hereby certifies that the information contained herein is a true, accurate and complete statement of all features relating to the claim asserted." Failure by the Contractor to provide sufficient documentation will result in denial of the claim. The County reserves the right to request additional documentation, or clarification of the documentation provided.
- (4) Upon receipt of a claim, the County will conduct a reasonable review and provide a written statement to the Contractor identifying what portion of the claim is disputed and what portion is undisputed within 45 days of receipt of the claim. The County and Contractor may, by mutual agreement, extend the 45 day time period. For any undisputed portion of a claim, the County must make payment within 60 days of its issuance of the written statement.
- (5) If the Contractor disputes the County's written statement, or if the County fails to respond, the Contractor may demand an informal conference to meet and confer for the settlement of the issues in dispute. The County will then schedule the meet and confer conference within 30 days of the demand. Within 10 business days following the meet and confer conference. The County will provide a written statement identifying the portion of the claim that remain in dispute. Any payment due on an undisputed portion of the claim will be made within 60 days of the meet and confer conference.
- (6) After the meet and confer conference, any disputed portion of the claim shall be submitted to non-binding mediation. Alternatively, upon receipt of a claim, the parties may mutually agree to waive in writing, mediation and proceed directly to the commencement of a civil action or binding arbitration as applicable, if mediation is unsuccessful, the parts of the claim that remain in dispute shall be subject to applicable procedures set forth below.
- (7) Failure of a public entity to respond to a claim within the time periods described above shall result in the claim being deemed rejected in its entirety. Additionally amounts not paid in a timely manner shall bear interest at 7 percent per year.
- (8) In the event that the mediation is unsuccessful, Contractor must file a government claim pursuant to Government Code Sections 910 et seq. in order to initiate a civil action.
- (9) In any civil action filed to resolve claims, the court shall submit the matter to nonbinding mediation within 60 days following the filing or responsive pleading provided that the parties have not already participated in mediation of the claim as outlined above. If the matter remains in dispute after nonbinding mediation, the court shall submit the matter to judicial arbitration pursuant to the Code of Civil Procedure Section 1141.10 et seq. If the matter remains in dispute after judicial arbitration, the County or the Contractor may request a trial de novo.

Article 72. MISCELLANEOUS

- (a) Entire Agreement. This Agreement contains the entire agreement between COUNTY and Contractor relating to the transactions contemplated hereby and supersedes all prior or contemporaneous agreements, understandings, provisions, negotiations, representations, or statements, either written or verbal.

- (b) Assignment. Neither this Agreement nor any duties or obligations hereunder shall be assignable by Contractor without the prior written consent of COUNTY.
- (c) Modification. No modification, waiver, amendment, discharge, or change of this Agreement shall be valid unless the same is in writing and signed by the Party against whom the enforcement of such modification, waiver, amendment, discharge, or change is or may be sought.
- (d) Captions. Captions in this Agreement are inserted for convenience of reference only and do not define, describe, or limit the scope or the intent of this Agreement or any of the terms thereof.
- (e) Partial Invalidity. If any provision in this Agreement is held by a court of competent jurisdiction to be invalid, void, or unenforceable, the remaining provisions will nevertheless continue in full force without being impaired or invalidated in any way.
- (f) Gender and Interpretation of Terms and Provisions. As used in this Agreement and whenever required by the context thereof, each number, both singular and plural, shall include all numbers, and each gender shall include a gender. Contractor as used in this Agreement or in any other document referred to in or made a part of this Agreement shall likewise include singular and the plural, a corporation, a partnership, individual, firm, or person acting in any fiduciary capacity as executor, administrator, trustee or in any other representative capacity or any other entity. All covenants herein contained on the part of Contractor shall be joint and several if more than one person, firm or entity executes this Agreement.
- (g) Waiver. No waiver of any breach or of any of the covenants or conditions of this Agreement shall be construed to be a waiver of any other breach or to be consent to any further or succeeding breach of the same or any other covenant or condition.
- (h) Attorneys' Fees and Costs. If either Party herein brings an action to enforce the terms thereof or to declare rights hereunder, the prevailing Party in any such action, on trial or appeal, shall be entitled to reasonable attorneys' fees as fixed by the court and actual costs to be paid by the losing Party.
- (i) Authority.
 - (1) Each individual executing this Agreement on behalf of Contractor represents and warrants that:
 - (A) He/She is duly authorized to execute and deliver this Agreement on behalf of Contractor;
 - (B) Such execution and delivery is in accordance with the terms of the Articles of Incorporation or Partnership, any by-laws or Resolutions of Contractor and;
 - (C) This Agreement is binding upon Contractor in accordance with its terms.
 - (2) Contractor shall deliver to COUNTY evidence acceptable to COUNTY of the foregoing within thirty days of execution of this Agreement.
- (j) Counterparts. This Agreement may be executed in counterparts.
- (k) Review of Agreement Terms. This Agreement has been reviewed and revised by legal counsel for both COUNTY and Contractor, and no presumption or rule that ambiguities shall be construed against the drafting Party shall apply to the interpretation or enforcement of the same or any subsequent amendments thereto.

IMPROVEMENT PLANS FOR SUNBEAM LAKE WADING AREA IMPROVEMENTS SEELEY, CA

ENGINEERING NOTES:

1. NOTHING CONTAINED IN THE CONTRACT DOCUMENTS SHALL CREATE, NOR SHALL BE CONSTRUED TO CREATE, ANY CONTRACTUAL RELATIONSHIP BETWEEN THE ENGINEER AND THE CONTRACTOR OR ANY SUBCONTRACTOR.
2. ANY VARIATIONS FROM THESE PLANS SHALL BE PROPOSED ON CONSTRUCTION FIELD PRINTS AND TRANSMITTED TO THE ENGINEER.
3. THE CONTRACTOR SHALL PROTECT AND MAINTAIN ALL EXISTING UTILITIES ON THE SITE. ANY DAMAGE TO EXISTING UTILITIES, WHETHER SHOWN OR NOT SHOWN ON THE DRAWINGS, SHALL BE REPAIRED AT THE CONTRACTOR'S EXPENSE.
4. EXISTING SURFACE FEATURES AND FENCING SHALL BE REPLACED IN KIND IF DAMAGED BY THE CONTRACTOR DURING CONSTRUCTION.
5. ANY INSPECTION BY THE COUNTY OR THE ENGINEER SHALL NOT, IN ANY WAY, RELIEVE THE CONTRACTOR FROM ANY OBLIGATION TO PERFORM THE WORK IN COMPLIANCE WITH APPLICABLE CODES AND AGENCY REQUIREMENTS.
6. NOT USED
7. NOT USED
8. PRIOR TO FINAL APPROVAL AND ACCEPTANCE OF THE WORK THE DEVELOPER/CONTRACTOR WILL BE REQUIRED TO CLEAN AND REPAIR THE ADJACENT (PUBLIC) ROADWAYS USED OR DAMAGED DURING THE COURSE OF CONSTRUCTION.
9. CONTRACTOR IS RESPONSIBLE FOR PROTECTING ALL DRAIN PIPES AND DRAINAGE FACILITIES FROM DAMAGE DURING ALL STAGES OF CONSTRUCTION. EXTRA CARE SUCH AS BERMING OVER PIPES, FLAGGING OR SIGNAGE SHOULD BE USED DURING CONSTRUCTION TO MAINTAIN COVER OR PROTECT THE PIPES.
10. THE ENGINEER MAKES NO REPRESENTATION OR GUARANTEE REGARDING EARTHWORK QUANTITIES OR THAT THE EARTHWORK FOR THIS PROJECT WILL BALANCE DUE TO THE VARYING FIELD CONDITIONS, CHANGING SOIL TYPES, ALLOWABLE CONSTRUCTION TOLERANCES AND CONSTRUCTION METHODS THAT ARE BEYOND THE CONTROL OF THE ENGINEER. PRIOR TO BIDDING THE WORK THE CONTRACTOR SHALL THOROUGHLY SATISFY HIMSELF AS TO THE ACTUAL CONDITIONS AND EARTHWORK QUANTITIES, IF ANY. NO CLAIM SHALL BE MADE AGAINST THE OWNER/DEVELOPER OR ENGINEER FOR ANY EXCESS OR DEFICIENCY THEREIN, ACTUAL OR RELATIVE.

EARTHWORK

- 1.01 CLEARING: REMOVE ALL PVC SPRINKLER LINES FROM ALL AREAS OF THE WORK BRUSH ALL VEGETATION FROM SOUTH 50 FEET OF LAKE COVE TO RECEIVE EXCAVATED SOIL. DISPOSE OF VEGETATION AS DIRECTED BY COUNTY.
- 1.02 GRADING: EXCAVATE NATIVE SOILS TO LINE AND GRADE AS SHOWN ON DRAWINGS PLACE EXCAVATED SOIL AND GRASS IN SOUTHERN END OF LAKE COVE. TRACK WALK SURFACE OF SOILS PLACED IN COVE AT 2 FOOT DEPTH INTERVALS PLACE FILL SOILS ALONG NORTH SIDE OF NEW WADING AREA TO ELEVATION INDICATED. TRACK WALK AND FINISH SURFACE SMOOTH.
THE FINISHED SURFACE OF GROUND AFTER COMPLETION OF GRADING SHALL BE WITHIN PLUS (HIGH) OR MINUS (LOW) 0.10 FOOT OF ELEVATIONS SHOWN ON THESE DRAWINGS.
THE ELEVATION OF FINISHED GROUND SURFACE BETWEEN ELEVATION SET OUT ON THESE DRAWINGS SHALL BE THAT OBTAINED BY STRAIGHT-LINE INTERPOLATION.
- 1.03 LINER COVER: PLACE 12 INCHES OF SAND FILL OVER HDPE LINER BY END DUMPING AND SPREADING IN FULL THICKNESS LAYER WITH A SMALL DOZER OR FRONT END LOADER, DO NOT SUBJECT HDPE LINER TO WHEEL LOADS.
FINE GRADE TO ±0.10 FEET OF LINE AND GRADE SHOWN ON DRAWINGS.
- 1.04 WALKPATH: PLACE 3 INCH THICK LAYER OF CRUSHER FINES OVER NATIVE SOIL AT LOCATIONS INDICATED ON DRAWINGS, WATER AND ROLL TO SMOOTH SURFACE.



SITE PLAN

SHEET INDEX

- 1.- TITLE SHEET
- 2.- GRADING PLAN
- 3.- DETAILS



Underground
Service Alert

Call: TOLL FREE

811

2 WORKING DAYS BEFORE YOU DIG

| | | | | | | | | | |
|--|---|--|---|-------------------|--|-----------------------------|------------------------------------|--|-----------|
| | PLANS PREPARED UNDER THE DIRECT SUPERVISION OF: | | COUNTY OF IMPERIAL PUBLIC WORKS DEPARTMENT APPROVED FOR CONSTRUCTION BY: | REVISION | DESCRIPTION | DATE | PROJECT: SUNBEAM LAKE IMPROVEMENTS | | SHEET No. |
| | JEFFREY O. LYON DATE: 4/12/19 | | JOHN A. GAY DIRECTOR OF PUBLIC WORKS DATE: Oct 29, 2020 | DATE: 9/30/21 | CLIENT: IMPERIAL COUNTY PUBLIC WORKS LOCATION: ROSS & DREW ROADS, SEELEY, CA APN/LEGAL: .. DATE: 4/12/19 | 7 PROJECT No. LE18233 | | | |

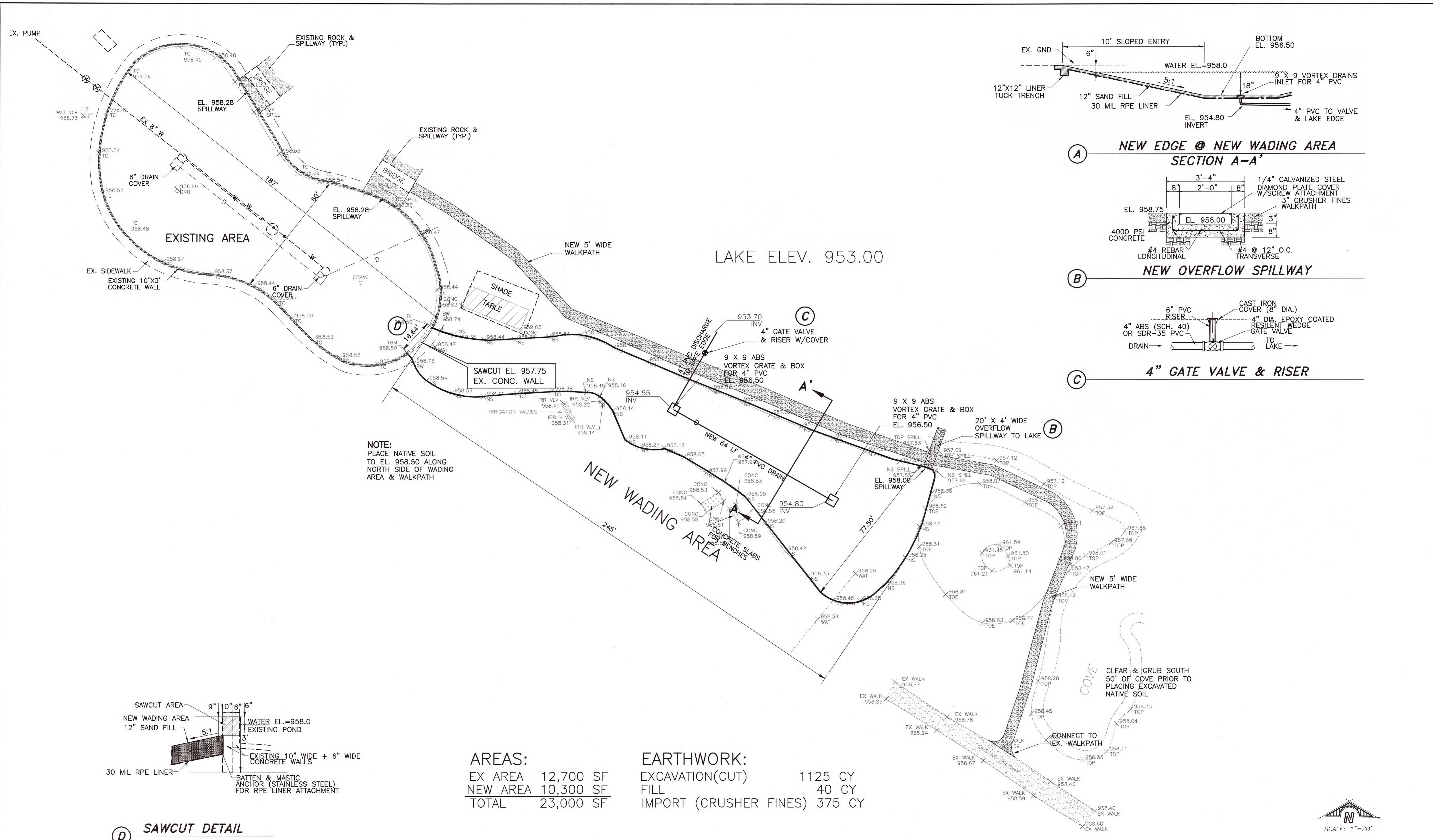

NOTE:
PLACE NATIVE SOIL
TO EL. 958.50 ALONG
NORTH SIDE OF WADING
AREA & WALKPATH

AREAS:

| | |
|----------|-----------|
| EX AREA | 12,700 SF |
| NEW AREA | 10,300 SF |
| TOTAL | 23,000 SF |

EARTHWORK:

| | |
|------------------------|---------|
| EXCAVATION(CUT) | 1125 CY |
| FILL | 40 CY |
| IMPORT (CRUSHER FINES) | 375 CY |

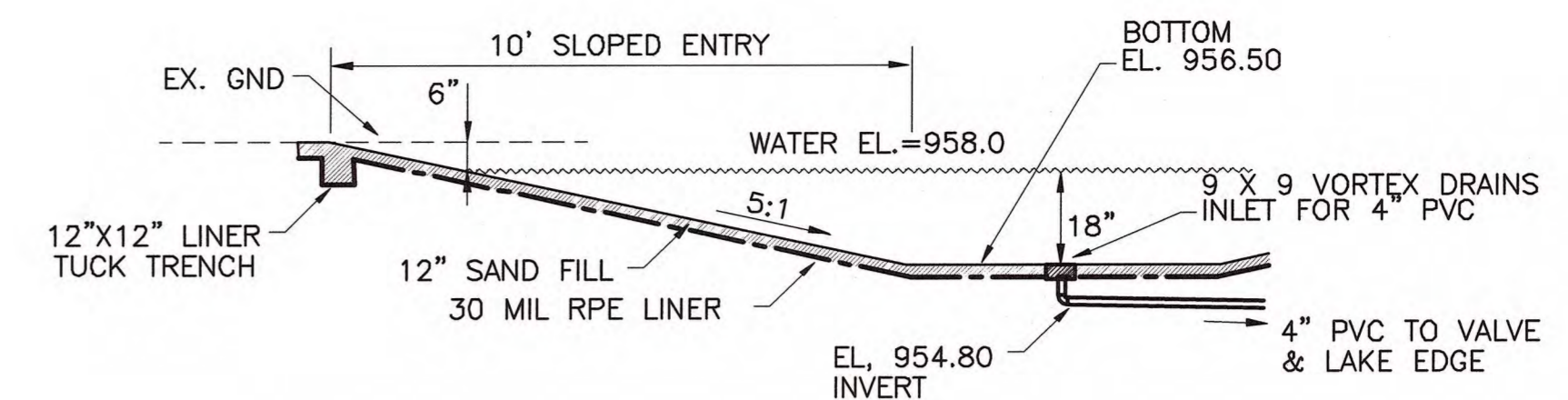

(A) NEW EDGE @ NEW WADING AREA SECTION A-A'

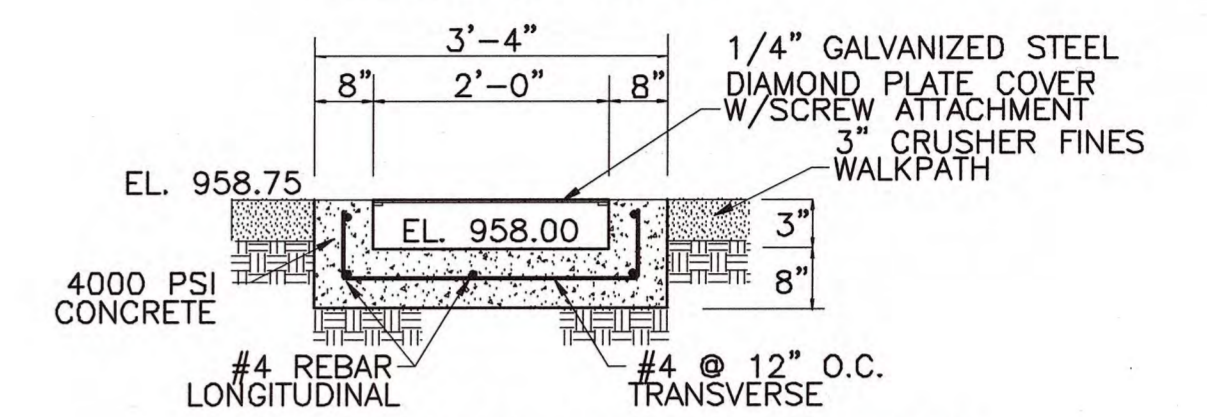

(B) NEW OVERFLOW SPILLWAY

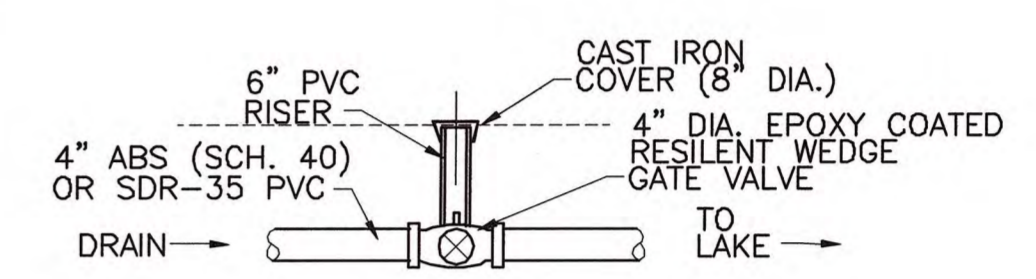

(C) 4\"/>

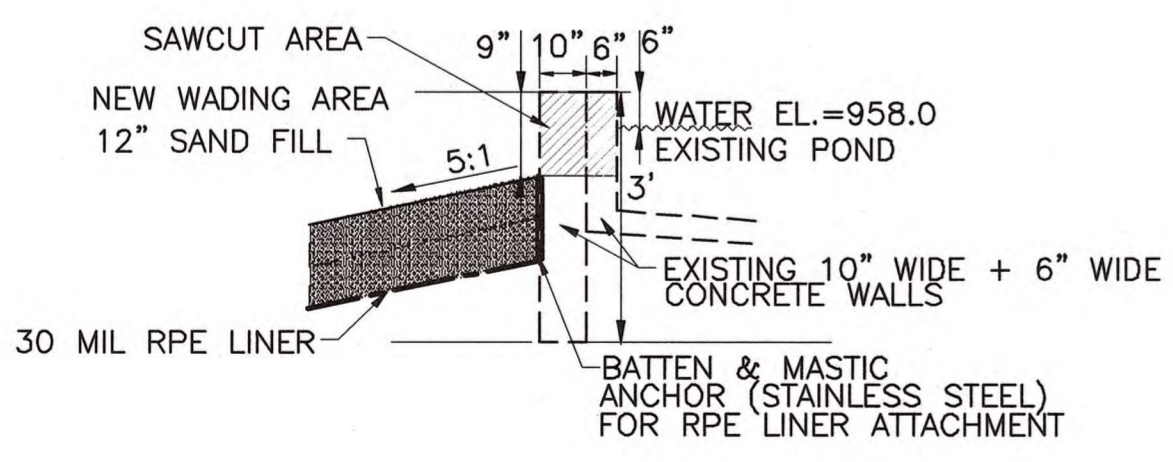

(D) SAWCUT DETAIL

GRADING PLAN

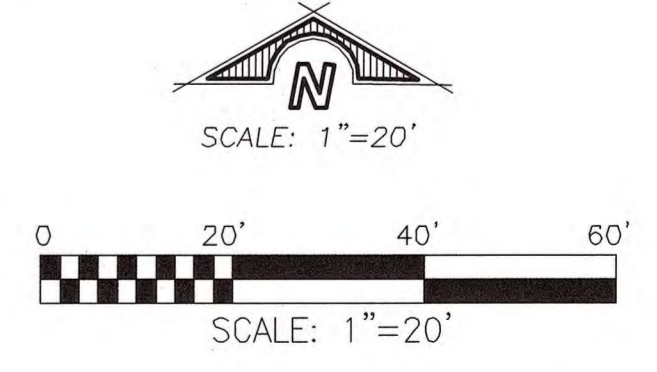

| | | | | | | | |
|--|---|--|---|---|---|---------------|---|
| | PLANS PREPARED UNDER THE DIRECT SUPERVISION OF: | | COUNTY OF IMPERIAL PUBLIC WORKS DEPARTMENT APPROVED FOR CONSTRUCTION BY: | REVISION | DESCRIPTION | DATE | PROJECT: SUNBEAM LAKE IMPROVEMENTS |
| | JEFFREY O. LYON DATE: 4/12/19 | | JOHN A. GAY DIRECTOR OF PUBLIC WORKS DATE: 10/29/2020 | COUNTY OF IMPERIAL PUBLIC WORKS DEPARTMENT APPROVED FOR CONSTRUCTION BY: | PROJECT: SUNBEAM LAKE IMPROVEMENTS CLIENT: IMPERIAL COUNTY PUBLIC WORKS LOCATION: ROSS & DREW ROADS, SEELEY, CA APN/LEGAL: ... | DATE: 4/12/19 | SHEET No. 2 PROJECT No. LE18233 |

MINIMUM LINER SPECIFICATIONS

AQUA 30 30MIL REINFORCED POLYETHYLENE

DATA SHEET

Heavyweight fabric incorporating a special weave pattern to enhance thickness, flatness, and tear properties. The coating recipe is designed to improve abrasion resistance. For use in geomembrane applications such as soil remediation, pond lining, canal, lining, landfill covers, etc.

| FABRIC SPECIFICATIONS | |
|----------------------------|--|
| WEAVE | Woven black HDPE scrim |
| COATING | 3.0 mil average each side |
| COLOR | Black |
| WEIGHT | 13.4 oz/yd ² (454 g/m ²) +/- 5% |
| THICKNESS | Nominal 30 mil (0.75 mm) +/- 10% ASTM D1777 |
| GRAB TENSILE | Warp 375lb 1668N Weft 315lb 1401N ASTM D751 |
| TOUNGE TEAR | Warp 270lb 1201N Weft 225lb 1000N ASTM D751 |
| TRAPEZOIDAL TEAR | Warp 100lb 444N Weft 90lb 400N ASTM D4533-04 |
| MULLEN BURST | 720 psi 4966 kPa ASTM D751 |
| HYDROSTATIC RESISTANCE | 610 psi 4196 kPa ASTM D751-00 |
| PERMEABILITY | <1.3 x 10 ⁻⁹ cm/sec ASTM D4491-99a |
| PUNCTURE RESISTANCE | 225 lb 1000 N ASTM D4833-00 |
| INDEX | |
| ACCELERATED UV WEATHERING1 | >90% strength retention after 2000 hours exposure @0.77 W/m ² /nm or 1200 hours exposure @ 1.35 W/m ² /nm ASTM G150-00 |

Q.U.V [A-340 Lamps]: 8 hrs UV @ 60°C; 4 hrs condensation @ 50°C

These values are typical data and are not intended as limiting specifications.

9X9 VORTEX PVC INLET BOX



HIGH DENSITY POLYETHYLENE LINER

INSTALLATION

A. GENERAL

1. SUBGRADE SHALL BE INSPECTED BY THE LINER INSTALLER PRIOR TO PLACEMENT OF THE LINER. UPON COMPLETION OF THE INSPECTION, THE INSTALLER SHALL EITHER IDENTIFY ANY WORKMANSHIP AND/OR MATERIALS WHICH ARE BELIEVED TO NOT BE IN COMPLIANCE WITH THE PROJECT PLANS AND SPECIFICATIONS, OR IF SUBGRADE IS FOUND TO BE ADEQUATE, ISSUE A CERTIFICATION TO THAT EFFECT TO THE CONTRACTOR. THE CONTRACTOR SHALL FORWARD THIS CERTIFICATION TO THE OWNER/ENGINEER.

2. LINER INSTALLATION MUST BE PERFORMED UNDER THE DIRECTION OF A FULL TIME EXPERIENCED INSTALLER. INSTALLER NEEDS TO POSSESS THE TECHNICAL EXPERTISE AND AUTHORITY TO DIRECT AND CERTIFY ALL WORK RELATED TO THE INSTALLATION OF THE LINER. THE INSTALLER WILL IDENTIFY IN WRITING SUBSTANDARD WORKMANSHIP AND/OR MATERIALS TO THE ENGINEER.

3. MANUFACTURES INSTALLATION AND SEAMING GUIDELINES REGARDING AMBIENT AIR AND LINER SURFACE TEMPERATURE (BOTH EXTREME HIGH AND LOW) MUST BE FOLLOWED DURING INSTALLATION. FAILURE TO DO SO CAN VOID WARRANTY AND RESULT IN LINER FAILURE.

B. SUBGRADE

ANY SOIL IN CONTACT WITH THE LINER MUST MEET THE FOLLOWING REQUIREMENT: THE SIX INCHES OF SOIL IMMEDIATELY BENEATH THE LINER SHALL BE FREE OF ALL ROCKS, STONES, STICKS, AND DEBRIS OF ANY KIND, WITH NO PARTICLE LARGER THAN THREE EIGHTHS INCH DIAMETER ANGULAR SHARP MATERIAL IS NOT ALLOWED IN THE SUBGRADE, REGARDLESS IN DIAMETER. THE SUBGRADE SHALL BE SMOOTH WITHOUT EXCAVATION EQUIPMENT MARKS OR RUTS AND SHALL BE ROLLED WITH A STEEL DRUM ROLLER TO FLATTEN ANY CLOUDS OF NATIVE CLAY SOIL.

C. PLACEMENT

1. LINER PANELS SHOULD BE LAID OUT ACCORDING TO PLANS SUPPLIED BY THE MANUFACTURER AND NO DEVIATION WILL BE ALLOWED EXCEPT WITH APPROVAL OF THE ENGINEER.

2. LINER PANELS MUST BE SECURED IN AN ANCHOR TRENCH AS SHOWN ON THE PLANS.

3. LINER PANELS WILL BE OVERLAPPING ACCORDING TO MANUFACTURERS' RECOMMENDATION. OVERLAP DISTANCE MUST BE SUFFICIENT SO THAT ALL SEAM TESTS CAN BE PERFORMED AS STATED IN THE VARIOUS TEST PROCEDURES. TYPICAL OVERLAPS ARE THREE TO SIX INCHES. THERE SHOULD BE NO LOOSE FLAP ON THE TOP SIDE OF THE LINER, RESULTING FROM THE OVERLAP SHOULD BE CUT OFF TO AVOID CATCHING DURING COVERING.

4. AT NO TIME DURING LINER PLACEMENT SHALL ANY VEHICLE BE ALLOWED DIRECTLY ON THE EXPOSED LINER.

D. SEAMING

1. ALL WELDS FOR SEAMING OF HDPE PANELS WILL BE MADE ACCORDING TO MANUFACTURER'S RECOMMENDATIONS.

2. WELDING EQUIPMENT USED FOR SEAMING SHOULD BE CAPABLE OF PRODUCING A CONTINUOUS HOMOGENEOUS BOND AT EVERY LOCATION, MEETING SEAM STRENGTH REQUIREMENTS.

3. PATCHES AND REPAIRS TO THE LINER SHOULD BE MADE WITHIN 48 HOURS OF DISCOVERY OF THE DEFECT USING AN EXTRUSION WELDING TECHNIQUE OR ANOTHER WELDING TECHNIQUE APPROVED BY THE ENGINEER. HAND HELD HOT AIR WELDING WILL NOT BE ALLOWED FOR GENERAL WELDS, PATCHES, OR REPAIR WELDS.

4. PATCHES SHOULD BE PLACED AS SOON AS POSSIBLE TO AVOID MISSING THEM. HAND HELD HOT AIR WELDING SHOULD BE USED FOR TACKING ONLY SINCE IT DOES NOT PRODUCE AN ACCEPTABLE FINAL WELD FOR PATCHES OR SEAMS. PATCHES SHOULD BE MADE FROM THE SAME MATERIAL AS THE LINER AND HAVE A CONTINUOUS ROUNDED EDGE WITH NO DISTINCT CORNERS. PATCHES SHOULD BE ROUNDED TO AVOID CORNERS THAT COULD CATCH DURING COVERING AND RIP OFF.

5. FISH MOUTHS ARE NOT ALLOWED. A FISH MOUTH IS DEFINED AS AN AREA IN THE SEAM WHERE ONE LINER PANEL IS FIRST FOLDED OVER ON ITSELF AND A SECOND LINER PANEL IS PLACED AND WELDED OVER THIS FOLD. WHERE FISH MOUTHS OCCUR, THE LINER MUST BE CUT, OVERLAPPED AND COVERED WITH A PATCH.

E. SEAM TESTING

1. NON-DESTRUCTIVE TESTING

A. NON-DESTRUCTIVE TESTS SHOULD BE PERFORMED BY THE CONTRACTOR OR ENGINEER ON ALL FIELD SEAMS, PATCHES, AND REPAIR WELDS.

B. THIS TEST SHOULD BE PERFORMED BY RUNNING A BLUNT INSTRUMENT ALONG THE EDGE OF THE SEAM TO FIND OBVIOUS UNBONDED AREAS.

C. VACUUM BOX TESTING SHOULD BE PERFORMED ON EVERY INCH OF EVERY FIELD SEAM AND PATCH.

F. BOOTS

EFFECTIVE SEAMS AND SEALS AROUND PIPES PENETRATING THROUGH THE LINER OR AROUND OTHER STRUCTURES ARE CRITICAL TO PREVENTING LEAKS. BOOTS AROUND PIPE PENETRATIONS SHOULD BE OF THE SAME MATERIAL AND THICKNESS AS THE SPECIFIED LINER. MANUFACTURER'S RECOMMENDATIONS FOR ATTACHING THE BOOT TO THE PIPE AND SEAMING THE BOOT TO THE LINER SHALL BE FOLLOWED. ALL PIPE BOOTS SHALL BE APPROPRIATELY SIZED TO THE DIMENSIONS OF THE PIPE AND FIT SNUGLY WITH NO WRINKLES OR FISHMOUTHS. THE LINER UNDER THE BOOT MUST REMAIN IN CONTACT WITH THE SUBGRADE SURFACE. WHEN STAINLESS STEEL PIPE BANDS ARE USED TO CLAMP THE BOOT TO THE PIPE, THE STRAPS SHALL NOT BE PLACED IN DIRECT CONTACT WITH THE PIPE BOOT MATERIAL. A NEOPRENE GASKET, OR OTHER MATERIAL SPECIFIED BY THE MANUFACTURER SHALL BE PLACED BETWEEN THE LINER AND PIPE BAND.

G. CERTIFICATION

UPON COMPLETION OF THE COVERING OPERATION, THE CONTRACTOR SHALL CERTIFY IN WRITING TO THE OWNER THAT ALL MATERIALS, EQUIPMENT, AND CONSTRUCTION HAVE BEEN COMPLETED IN CONFORMANCE WITH THE PLANS AND SPECIFICATIONS.

SPECIFICATIONS

| | | | | | | | |
|--|---|--|---|---|-------------|------|---|
| | PLANS PREPARED UNDER THE DIRECT SUPERVISION OF: | | COUNTY OF IMPERIAL PUBLIC WORKS DEPARTMENT APPROVED FOR CONSTRUCTION BY: | REVISION | DESCRIPTION | DATE | PROJECT: SUNBEAM LAKE IMPROVEMENTS |
| | JEFFREY O. LYON DATE: 4/17/19 | | JOHN A. GAFF DIRECTOR OF PUBLIC WORKS DATE: 10/29/2020 | 62028 R.C.E. No. 9/30/21 REG. EXP. | | | |
| | | | | | | | LOCATION: ROSS & DREW ROADS, SEELEY, CA |
| | | | | | | | APN/LEGAL: .. DATE: 4/12/19 |

LANDMARK
Geo-Engineers and Geologists

780 NORTH 4TH STREET
EL CENTRO, CA 92243
(760) 370-3000 FAX (760) 337-8900

SHEET No.

3

PROJECT No.
LE18233

1 **AGREEMENT FOR CONSTRUCTION SERVICES**

2 «Consultant_Business_Name»

3 THIS AGREEMENT FOR CONSTRUCTION SERVICES (“Agreement”), made and entered
4 into effective the ____ day of _____, 2018, by and between the COUNTY OF IMPERIAL, a
5 political subdivision of the State of California, through its Department of Public Works (“COUNTY”)
6 and «Consultant_Business_Name», a «Consultant_Business_Type» licensed to do business within the
7 state of California (“CONTRACTOR”) (individually, “Party;” collectively, “Parties”) shall be as
8 follows:

9 **RECITALS**

10 **WHEREAS**, COUNTY desires to retain a qualified individual, firm or business entity to
11 provide professional construction services for Imperial County Project Number «Project_Number»,
12 «Project_Name»; and

13 **WHEREAS**, COUNTY wishes to engage CONTRACTOR for performance of such services as
14 are provided for herein and CONTRACTOR is willing to accept such engagement;

15 **NOW, THEREFORE**, COUNTY and CONTRACTOR have and hereby agree to the
16 following:

17 **1. DEFINITIONS.**

18 **1.1.** “Invitation for Bid” shall mean the document entitled, “«Name_of_RFP»,” dated
19 «Date_of_RFP», which includes all special notices, addendums, exhibits and Plans
20 and Specifications as defined in Paragraph 1.3. The Invitation for Bid is attached
21 hereto as **Exhibit “A”** and incorporated herein as though fully set forth.

22 **1.2.** “Proposal” shall mean CONTRACTOR’s document entitled “«Name_of_Proposal»,”
23 dated «Date_of_Proposal» and submitted to the Clerk of the Board. The Proposal is
24 attached hereto as **Exhibit “B”** and incorporated herein as though fully set forth.

25 “Plans and Specifications” shall mean the plans and specifications approved by the Director of
26 Public Works, or his/her designee, for Project Number «Project_Number». While COUNTY is
27 responsible for the completeness and accuracy of the Plans and Specifications for the Project,
28 CONTRACTOR is required to review the Plans and Specifications and promptly report any errors or
omissions to COUNTY.

1 ///

2 **2. CONTRACT COORDINATION.**

3 **2.1.** The Director of Public Works or his/her designee shall be the representative of
4 COUNTY for all purposes under this Agreement. The Director of Public Works or
5 his/her designee is hereby designated as the Contract Manager for COUNTY. He/she
6 shall supervise the progress and execution of this Agreement.

7 **2.2.** CONTRACTOR shall assign a single Contract Manager to have overall responsibility
8 for the progress and execution of this Agreement. Should circumstances or conditions
9 subsequent to the execution of this Agreement require a substitute Contract Manager for
10 any reason, the Contract Manager designee shall be subject to the prior written
11 acceptance and approval of COUNTY's Contract Manager.

12 **3. SCOPE OF WORK TO BE PERFORMED BY CONTRACTOR.**

13 **3.1.** CONTRACTOR shall furnish all work, labor, tools, equipment, materials, supervision,
14 scheduling, coordination and contract administration necessary to construct and
15 complete the Project in a good, expeditious, workman-like and substantial manner under
16 the terms of and in full and complete compliance with this Agreement ("Work").

17 **3.2.** CONTRACTOR shall comply with and perform work consistent with all terms,
18 conditions and requirements of the Plans, Specifications, the Invitation for Bids and
19 this Agreement.

20 **3.3.** All described work shall be constructed, installed, placed and performed in conformance
21 with the Plans and Specifications and all Special Provisions contained therein and as
22 directed by COUNTY's engineer.

23 **3.4.** In the event of a conflict among this Agreement, the Invitation for Bid and the Proposal,
24 the Invitation for Bid shall take precedence over the Proposal and this Agreement shall
25 take precedence over both.

26 **3.5.** CONTRACTOR shall perform such other tasks as necessary and proper for the full
27 performance of the obligations assumed by CONTRACTOR hereunder; including but
28 not limited to any additional work or change orders agreed upon pursuant to written
authorization as described in Section 5. Proposed additional work or change order

1 requests, when applicable, will be attached and incorporated herein under **Exhibit "B"**
2 (as "B-1," "B-2," etc.).

3 **4. TRENCHING REQUIREMENTS AND UTILITY RELOCATION.**

4 **4.1. Four Feet (4') Below the Surface.** In the event the Project involves digging trenches or
5 other excavations that extend deeper than four feet (4') below the surface,
6 CONTRACTOR shall:

7 **4.1.1.** Promptly, and before the following conditions are disturbed, notify COUNTY,
8 in writing, of any:

- 9 (a) Material that CONTRACTOR believes may be material that is
10 hazardous waste, as defined in Health & Safety Code §25117, that is
11 required to be removed to a Class I, Class II or Class III disposal site
12 in accordance with provisions of existing law;
- 13 (b) Subsurface or latent physical conditions at the site differing from those
14 indicated by information about the site made available to bidders prior
15 to the deadline for submitting bids; and
- 16 (c) Unknown physical conditions at the site of any unusual nature,
17 different materially from those ordinarily encountered and generally
18 recognized as inherent in work of the character provided for in the
19 Agreement.

20 **4.1.2.** In response to any written notice generated pursuant to Subparagraph 4.1.1,
21 COUNTY shall promptly investigate the conditions, and if it finds that the
22 conditions do materially so differ, or do involve hazardous waste, and cause a
23 decrease or increase in CONTRACTOR's cost of, or the time required for,
24 performance of any part of the Work, COUNTY shall issue a change order
25 under the procedures described in this Agreement.

26 **4.1.3.** In the event that a dispute arises between COUNTY and CONTRACTOR
27 whether the conditions materially differ, or involve hazardous waste, or cause
28 a decrease or increase in CONTRACTOR's cost of, or time required for,
performance of any part of the Work, CONTRACTOR shall not be excused

1 from any scheduled completion date provided for by this Agreement, but shall
2 proceed with all Work to be performed under this Agreement.
3 CONTRACTOR shall retain any and all rights provided either by contract or
4 by law which pertain to the resolution of disputes and protests between the
5 Parties.

6 **4.2. Trenching Requirements – Project in Excess of Twenty-Five Thousand Dollars**
7 **(\$25,000) and Five Feet (5’) Below the Surface.** For projects involving both an
8 estimated expenditure in excess of twenty-five thousand dollars (\$25,000) and the
9 excavation of any trench five feet (5’) or more in depth, CONTRACTOR shall submit
10 a detailed plan showing the design of shoring, bracing, sloping or other provisions to
11 be made for worker protection from the hazard of caving ground during the
12 excavation of such trench. The plan must be accepted by COUNTY (or by a
13 registered civil or structural engineer, employed by COUNTY, to whom authority to
14 accept has been delegated) in advance of excavation. If such plan varies from the
15 shoring system standards, the plan shall be prepared by a registered civil or structural
16 engineer. Nothing in this Paragraph shall allow CONTRACTOR to use a shoring,
17 sloping, or protective system less effective than that required by California
18 Construction Safety Orders. Further, nothing in this Paragraph shall be construed to
19 impose tort liability on COUNTY or any of its employees.

20 **4.3. Utilities Relocation.** In the event that CONTRACTOR, in the scope of work,
21 encounters utilities not shown on COUNTY’S plans, COUNTY shall compensate
22 CONTRACTOR for utilities relocation work. COUNTY shall also waive liquidated
23 damages for any delay that occurs as a result of said encounter and/or relocation of
24 utilities.

25 **5. CHANGE ORDERS.**

26 **5.1. Change Orders.** CONTRACTOR shall make no changes to the Work to be performed
27 pursuant to this Agreement, including but not limited to additions, deletions,
28 modifications or substitutions, nor shall CONTRACTOR perform any extra work
(collectively, “Change Order Work”) without the prior written consent of COUNTY. If

1 CONTRACTOR encounters conditions it considers different from those described in
2 **Exhibit “A”** to this Agreement, CONTRACTOR may request a change order in
3 conformance with COUNTY’s standard procedure (“Change Order”). If COUNTY
4 approves the request, CONTRACTOR will execute a Change Order and
5 CONTRACTOR’s execution of the Change Order shall confirm approval thereof.
6 COUNTY may order additional work, and CONTRACTOR shall perform such changes
7 in the Work as directed by COUNTY in any Change Order prepared by
8 CONTRACTOR. COUNTY’s rights to eliminate portions of the Work or to initiate a
9 Change Order shall not be limited in any way. The Change Order shall be in writing
10 and shall include:

11 **5.1.1.** Any and all supporting documents and drawings depicting the source and
12 location of the desired change, and explain in detail the field conditions and
13 reasons for the requested change;

14 **5.1.2.** Any change or adjustment to the compensation set forth in this Agreement as a
15 result of changes in the Work based on a lump sum or time and material basis, as
16 may be directed by COUNTY; and

17 **5.1.3.** Any request for adjustments to time for completion of the Project.

18 **5.2.** Payment for Change Order Work. CONTRACTOR shall not be entitled to receive any
19 compensation for work, labor, materials or changes of any kind, regardless of whether
20 ordered by COUNTY or any of its representatives, unless a Change Order has been
21 submitted in writing and approved prior to the commencement of any Change Order
22 Work as described above. If the changes are required by any inspecting governmental
23 agencies or utility companies, or are otherwise required to comply with any codes, laws,
24 rules or regulations, including those set forth in this Agreement, then CONTRACTOR
25 shall not be entitled to any increases in the compensation set forth in this Agreement or
26 other compensation as a result of the changes.

27 **5.3.** Disputed Change Order Work. Any dispute concerning the performance of such
28 Change Order Work or the amount of compensation to be paid to CONTRACTOR by
COUNTY shall not affect CONTRACTOR’s obligation to perform such Change Order

1 Work. CONTRACTOR agrees that it shall timely complete all Change Order Work
2 even if there shall be a dispute between CONTRACTOR and COUNTY over the
3 amount or scope of the Change Order Work. CONTRACTOR shall have the right to be
4 compensated for any undisputed Change Order Work amounts as determined to be
5 undisputed in COUNTY's sole discretion.

6 **5.4. Authorized Representative.** No Change Order shall be valid or binding against
7 COUNTY unless such Change Order has been executed by COUNTY's designated
8 representative, who is the Director of Public Works. COUNTY shall notify
9 CONTRACTOR in writing if the designated representative is changed.

10 **5.5. Limits.** When applicable, the authority to execute a Change Order on this Project shall
11 not exceed the amount allowed by law pursuant to Public Contract Code sections 20137-
12 20142 et seq. Where Change Orders are in an amount between ten percent (10%) and
13 twenty-five percent (25%) of the amount set forth in this Agreement and based on a
14 need for additional quantities due to an increase in the unit quantities required to
15 complete the project in excess of the COUNTY's Engineer's estimate of unit quantities
16 as set forth in the Invitation to Bid, CONTRACTOR shall be paid pursuant to Public
17 Contract Code sections 20143 and 20139 and section 4 of the Standard Specifications,
18 State of California, Business, Transportation and Housing Agency, May 2006 Issued by
19 the Department of Transportation ("Caltrans Standard Specifications") referred to in
20 **Exhibit "A"** and incorporated herein by reference.

21 **6. REPRESENTATIONS BY CONTRACTOR.**

22 **6.1.** CONTRACTOR understands and agrees that COUNTY has limited knowledge in the
23 construction specified in the description of work. CONTRACTOR has represented
24 itself to be expert in these fields and understands that COUNTY is relying upon such
25 representation.

26 **6.2.** CONTRACTOR represents and warrants that it is a lawful entity possessing all
27 required licenses and authorities to do business in the State of California and perform
28 all aspects of this Agreement.

6.3. CONTRACTOR shall not commence any work under this Agreement or provide any

1 other services, or materials, in connection therewith until CONTRACTOR has
2 received written authorization from the Director of Public Works, or his/her designee
3 (“Notice to Proceed”) to do so.

4 **6.4.** CONTRACTOR represents and warrants that the people executing this Agreement on
5 behalf of CONTRACTOR have the authority of CONTRACTOR to sign this
6 Agreement and bind CONTRACTOR to the performance of all duties and obligations
7 assumed by CONTRACTOR herein.

8 **6.5.** CONTRACTOR represents and warrants that any employee, contractor, subcontractor
9 and agent who will be performing any of the duties and obligations of CONTRACTOR
10 herein possess all required licenses and authorities, as well as the experience and
11 training, to perform such tasks.

12 **6.6.** CONTRACTOR represents and warrants that the allegations contained in its Proposal
13 are true and correct.

14 **6.7.** CONTRACTOR understands that COUNTY considers the representations made
15 herein to be material and would not enter into this Agreement with CONTRACTOR
16 if such representations were not made.

17 **6.8.** Retention and Access of Books and Records. CONTRACTOR represents and
18 warrants that it shall maintain books, records, documents, reports and other materials
19 developed under this Agreement as follows:

20 **6.8.1.** CONTRACTOR shall hold and possess as the property of COUNTY all
21 papers, books, files, correspondence and other records of all kinds which at
22 any time shall come into its possession or under its control relating only to
23 services performed by CONTRACTOR under this Agreement for a minimum
24 period of five (5) years, or for any longer period required by law, from the
25 date said papers came into the possession of CONTRACTOR pursuant to this
26 Agreement.

27 **6.8.2.** Any records or documents required to be maintained by CONTRACTOR
28 pursuant to this Agreement shall be made available to COUNTY for
inspection or audit, at any time during CONTRACTOR’s regular business

1 hours provided COUNTY provides CONTRACTOR with seven (7) days
2 advanced written or oral notice. Copies of such documents shall, at no cost to
3 COUNTY, be provided to COUNTY for inspection at CONTRACTOR's
4 address indicated for receipt of notices under this Agreement.

5 **6.8.3.** CONTRACTOR shall surrender all papers maintained by CONTRACTOR
6 pursuant to Subparagraph 6.8.1 of this Agreement within thirty (30) days of
7 termination of this Agreement.

8 **6.8.4.** CONTRACTOR represents and warrants that it has not been engaged by, nor
9 will it be engaged by and owes no duty of performance to any other person or
10 entity that would constitute a conflict. For breach or violation of this
11 warranty, COUNTY shall amongst other remedies at law, have the right to
12 terminate this Agreement without liability, or at its sole discretion, to deduct
13 from the Agreement price or consideration, or otherwise recover the full
14 amount of such fee, commission, percentage brokerage fee, gift or contingent
15 fee paid or received from another entity or person.

16 **6.9.** CONTRACTOR represents and warrants that it and its subcontractors are not
17 ineligible to work for COUNTY due to violations of Labor Code §§1777.1 and
18 1777.7.

19 **6.10.** CONTRACTOR shall perform pursuant to this Agreement in accordance with and in
20 full compliance with all applicable Federal, State and local statues, rules, regulations
21 and policies and procedures, regardless of whether they are expressly set forth in this
22 Agreement. It is understood that in the event COUNTY is investigated or audited by
23 any State or Federal governmental agency, or any other recognized
24 investigative/auditing entity, CONTRACTOR shall fully cooperate with such
25 agencies' reasonable and lawful request for information.

26 **7. TERM OF AGREEMENT.**

27 This Agreement shall commence on the date first written above and shall remain in effect
28 until the services provided as outlined in Section 3, ("SCOPE OF WORK TO BE PERFORMED BY
CONTRACTOR"), have been completed, unless otherwise terminated as provided for in this

1 Agreement.

2 **8. COMPENSATION.**

3 The total compensation payable under this Agreement shall be in accordance with the item
4 prices incorporated within the Proposal submitted by CONTRACTOR for labor, materials and all
5 other services related to the performance of this Agreement, attached hereto as **Exhibit "B"** and
6 incorporated herein as though fully set forth. The total compensation payable under this Agreement
7 shall not exceed «Cost_of_Original_Contract».

8 **9. PAYMENT.**

9 COUNTY shall pay CONTRACTOR for completed and approved services upon presentation
10 and approval of its itemized billing. COUNTY shall retain five percent (5%) of the total
11 compensation until the Work to be performed has been completed in accordance with this
12 Agreement, as determined by COUNTY, and payment in full of all subcontractors of
13 CONTRACTOR has been certified. However, CONTRACTOR may elect to substitute securities or
14 execute an escrow agreement (in the form prescribed by the Public Contracts Code) in place of
15 retained funds held by COUNTY pursuant to Public Contract Code §22300.

16 **10. METHOD OF PAYMENT.**

17 **10.1.** CONTRACTOR shall at any time prior to the fifteenth (15th) day of any month,
18 submit to COUNTY's Director of Public Works or his/her designee, a complete and
19 accurate written claim for compensation for services performed. The claim shall be
20 in a format approved by COUNTY. COUNTY shall make no payment prior to the
21 claims being approved in writing by the Director of Public Works or his/her designee.

22 **10.2.** After determining that the claim is a proper payment request, the Director of Public
23 Works, or his/her designee, shall submit to COUNTY's Auditor/Controller
24 undisputed and properly submitted claims approved for payment within ten (10) days
25 following the date the claim was submitted to his/her Department.

26 **10.3.** CONTRACTOR may expect to receive payment within a reasonable time thereafter
27 and in any event in the normal course of business within thirty (30) days after the
28 undisputed and properly submitted claim is submitted.

10.4. Any claim determined to be an improper payment request shall be returned to

1 CONTRACTOR as soon as practicable, but not later than seven (7) days, after receipt
2 with a written explanation as to why the claim is an improper request for payment.

3 **10.5.** In order for prompt payment to be made by COUNTY pursuant to Public Contract Code
4 §20104.50, CONTRACTOR must properly fill out all written claims for compensation
5 for services performed.

6 **10.6.** COUNTY shall pay interest at the legal rate set forth in Code of Civil Procedure
7 §685.010 in the event payment is not made within thirty (30) days of an undisputed
8 properly submitted request.

9 **11. INDEMNIFICATION.**

10 **11.1.** CONTRACTOR agrees to the fullest extent permitted by law to indemnify, defend,
11 protect and hold COUNTY and its representatives, officers, directors, designees,
12 employees, agents, successors and assigns harmless from any and all claims,
13 expenses, liabilities, causes of action, demands, losses, penalties, attorneys' fees and
14 costs, in law or equity, of every kind and nature whatsoever arising out of or in
15 connection with CONTRACTOR's negligent acts and omissions or willful
16 misconduct under this Agreement ("Claims"), whether or not arising from the passive
17 negligence of COUNTY, but does not include Claims that are finally determined to
18 be the result of the sole negligence or willful misconduct of COUNTY.

19 **11.2.** CONTRACTOR agrees to defend with counsel acceptable to COUNTY, indemnify
20 and hold COUNTY harmless from all Claims, including but not limited to:

21 **11.2.1.** Personal injury, including but not limited to bodily injury, emotional injury,
22 sickness or disease or death to persons including but not limited to
23 COUNTY's representatives, officers, directors, designees, employees, agents,
24 successors and assigns, subcontractors and other third parties and/or damage
25 to property of anyone (including loss of use thereof) arising out of
26 CONTRACTOR's negligent performance of, or willful misconduct
27 surrounding, any of the terms contained in this Agreement, or anyone directly
28 or indirectly employed by CONTRACTOR or anyone for whose acts
CONTRACTOR may be liable;

1 **11.2.2.** Liability arising from injuries to CONTRACTOR and/or any of
2 CONTRACTOR's employees or agents arising out of CONTRACTOR's
3 negligent performance of, or willful misconduct surrounding, any of the terms
4 contained in this Agreement, or anyone directly or indirectly employed by
5 CONTRACTOR or anyone for whose acts CONTRACTOR may be liable;

6 **11.2.3.** Penalties imposed upon account of the violation of any law, order, citation,
7 rule, regulation, standard, ordinance or statute caused by the negligent action
8 or inaction, or willful misconduct of CONTRACTOR or anyone directly or
9 indirectly employed by CONTRACTOR or anyone for whose acts
10 CONTRACTOR may be liable, including but not limited to:

11 **(a)** Any loss of funding, penalties, fees, or other costs resulting from
12 CONTRACTOR's failure to adhere to Disadvantaged Business
13 Enterprise requirements and/or goals, as determined by COUNTY or
14 such other lawful entity in charge of monitoring Disadvantaged
15 Business Enterprise compliance;

16 **(b)** Any loss of funding, penalties, fees, or other costs resulting from
17 CONTRACTOR's failure to adhere to prevailing wage requirements,
18 as determined by COUNTY, the California Department of Industrial
19 Relations, or such other lawful entity in charge of monitoring
20 prevailing wage compliance;

21 **11.2.4.** Infringement of any patent rights which may be brought against COUNTY
22 arising out of CONTRACTOR's work;

23 **11.2.5.** Any violation or infraction by CONTRACTOR of any law, order, citation,
24 rule, regulation, standard, ordinance or statute in any way relating to the
25 occupational health or safety of employees; and

26 ///

27 **11.2.6.** Any breach by CONTRACTOR of the terms, requirements or covenants of
28 this Agreement.

11.3. The indemnification provisions of this Agreement shall extend to Claims occurring

after this Agreement is terminated, as well as while it is in force.

12. INDEPENDENT CONTRACTOR.

12.1. In all situations and circumstances arising out of the terms and conditions of this Agreement, CONTRACTOR is an independent contractor, and as an independent contractor, the following shall apply:

12.2. CONTRACTOR is not an employee or agent of COUNTY and is only responsible for the requirements and results specified by this Agreement.

12.3. CONTRACTOR shall be responsible to COUNTY only for the requirements and results specified by this Agreement and except as specifically provided in this Agreement, shall not be subject to COUNTY's control with respect to the physical actions or activities of CONTRACTOR in fulfillment of the requirements of this Agreement.

12.4. CONTRACTOR is not, and shall not be, entitled to receive from, or through, COUNTY, and COUNTY shall not provide, or be obligated to provide, CONTRACTOR with Worker's Compensation coverage or any other type of employment or worker insurance or benefit coverage required or provided by any Federal, State or local law or regulation for, or normally afforded to, an employee of COUNTY.

12.5. CONTRACTOR shall not be entitled to have COUNTY withhold or pay, and COUNTY shall not withhold or pay, on behalf of CONTRACTOR, any tax or money relating to the Social Security Old Age Pension Program, Social Security Disability Program, or any other type of pension, annuity, or disability program required or provided by any Federal, State or local law or regulation.

12.6. CONTRACTOR shall not be entitled to participate in, or receive any benefit from, or make any claim against any COUNTY fringe benefit program, including, but not limited to, COUNTY's pension plan, medical and health care plan, dental plan, life insurance plan, or any other type of benefit program, plan, or coverage designated for, provided to, or offered to COUNTY's employee.

12.7. COUNTY shall not withhold or pay, on behalf of CONTRACTOR, any Federal,

1 State, or local tax, including, but not limited to, any personal income tax, owed by
2 CONTRACTOR.

3 **12.8.** CONTRACTOR is, and at all times during the term of this Agreement shall represent
4 and conduct itself as, an independent contractor, not an employee of COUNTY.

5 **12.9.** CONTRACTOR shall not have the authority, express or implied, to act on behalf of,
6 bind or obligate COUNTY in any way without the written consent of COUNTY.

7 **13. INSURANCE.**

8 **13.1.** CONTRACTOR hereby agrees at its own cost and expense to procure and maintain,
9 during the entire term of this Agreement and any extended term therefore, insurance
10 in a sum acceptable to COUNTY and adequate to cover potential liabilities arising in
11 connection with the performance of this Agreement and in any event not less than the
12 minimum limit set forth in the "Minimum Insurance Amounts" attachment to the
13 Plans and Specifications which are incorporated as if set forth fully herein.

14 **13.2. Special Insurance Requirements.** All insurance required shall:

15 **13.2.1.** Be procured from California admitted insurers (licensed to do business in
16 California) with a current rating by Best's Key Rating Guide, acceptable to
17 COUNTY. A rating of at least A-VII shall be acceptable to COUNTY; lesser
18 ratings must be approved in writing by COUNTY.

19 **13.2.2.** Be primary coverage as respects COUNTY and any insurance or self-
20 insurance maintained by COUNTY shall be in excess of CONTRACTOR's
21 insurance coverage and shall not contribute to it.

22 **13.2.3.** Name COUNTY as an additional insured on all policies, except Workers'
23 Compensation, and provide that COUNTY may recover for any loss suffered
24 by COUNTY by reason of CONTRACTOR's negligence.

25 **13.2.4.** State that it is primary insurance and regards COUNTY as an additional
26 insured and contains a cross-liability or severability of interest clause.

27 **13.2.5.** Not be canceled, non-renewed or reduced in scope of coverage until after
28 thirty (30) days written notice has been given to COUNTY. However,
CONTRACTOR may not terminate such coverage until it provides COUNTY

1 with proof that equal or better insurance has been secured and is in place.
2 Cancellation or change without the prior written consent of COUNTY shall, at
3 the option of COUNTY, be grounds for termination of this Agreement.

4 **13.2.6.** If this Agreement remains in effect more than one (1) year from the date of its
5 original execution, COUNTY may, at its sole discretion, require an increase in
6 the amount of liability insurance to the level then customary in similar
7 COUNTY Agreements by giving sixty (60) days notice to CONTRACTOR.

8 **13.3.** Additional Insurance Requirements.

9 **13.3.1.** COUNTY is to be notified immediately of all insurance claims. COUNTY is
10 also to be notified if any aggregate insurance limit is exceeded.

11 **13.3.2.** The comprehensive or commercial general liability shall contain a provision
12 of endorsements stating that such insurance:

- 13 (a) Includes contractual liability;
- 14 (b) Does not contain any exclusions as to loss or damage to property
15 caused by explosion or resulting from collapse of buildings or
16 structures or damage to property underground, commonly referred to
17 by insurers as the "XCU Hazards";
- 18 (c) Does not contain a "pro rata" provision which looks to limit the
19 insurer's liability to the total proportion that its policy limits bear to
20 the total coverage available to the insured;
- 21 (d) Does not contain an "excess only" clause which requires the
22 exhaustion of other insurance prior to providing coverage;
- 23 (e) Does not contain an "escape clause" which extinguishes the insurer's
24 liability if the loss is covered by other insurance;
- 25 (f) Includes COUNTY as an additional insured; and
- 26 (g) States that it is primary insurance and regards COUNTY as an
27 additional insured and contains a cross-liability or severability of
28 interest clause.

13.4. Deposit of Insurance Policy. Promptly on issuance, reissuance, or renewal of any

1 insurance policy required by this Agreement, CONTRACTOR shall, if requested by
2 COUNTY, cause to be given to COUNTY satisfactory evidence that insurance policy
3 premiums have been paid together with a duplicate copy of the policy or a certificate
4 evidencing the policy and executed by the insurance company issuing the policy or its
5 authorized agent.

6 **13.5. Certificates of Insurance.** Complete copies of certificates of insurance for all required
7 coverages including additional insured endorsements shall be attached hereto as
8 **Exhibit “C”** and incorporated herein as though fully set forth.

9 **13.6. Additional Insurance.** Nothing in this, or any other provision of this Agreement, shall
10 be construed to preclude CONTRACTOR from obtaining and maintaining any
11 additional insurance policies in addition to those required pursuant to this Agreement.

12 **14. WORKERS’ COMPENSATION CERTIFICATION.**

13 **14.1.** Prior to the commencement of work, CONTRACTOR shall sign and file with
14 COUNTY the following certification: “I am aware of the provisions of California
15 Labor Code §§3700 et seq. which require every employer to be insured against
16 liability for workers’ compensation or to undertake self-insurance in accordance with
17 the provisions of that code, and I will comply with such provisions before
18 commencing the performance of the work of this contract.”

19 **14.2.** This certification is included in this Agreement and signature of the Agreement shall
20 constitute signing and filing of the certificate.

21 **14.3.** CONTRACTOR understands and agrees that any and all employees, regardless of
22 hire date, shall be covered by Workers’ Compensation pursuant to statutory
23 requirements prior to beginning work on the Project.

24 **14.4.** If CONTRACTOR has no employees, initial here: _____.

25 **15. WARRANTY.**

26 **15.1. One Year Warranty.** CONTRACTOR agrees to provide a one-year warranty for all
27 of its work and component parts and guarantees that all work shall be performed in a
28 professional and workman-like manner and be free from defects. CONTRACTOR
guarantees to timely correct all work performed by it under this Agreement which

COUNTY determines to be defective in design, material and/or workmanship within a period of one (1) year from the date of the completion of the Work. The warranties set forth in this Agreement shall be in addition to, and not in lieu of, all other statutory and case law warranties and obligations of CONTRACTOR. CONTRACTOR expressly agrees that all warranties made by CONTRACTOR, all obligations under this Agreement and all remedies for breach of such warranties shall survive this Agreement in the event it is terminated or expires for any reason prior to the running of the full warranty periods listed above.

15.2. Materials. All materials furnished by CONTRACTOR shall be new, manufactured during the current year, of first quality and carrying full manufacturer's warranty. CONTRACTOR shall be responsible for any expiration of manufacturer or other warranties of material or equipment being supplied for this Agreement. CONTRACTOR guarantees that all warranties of material and equipment shall become effective when the project is accepted by COUNTY's Board of Supervisors, not at time of installation by CONTRACTOR.

15.3. Manufacturers' Warranty Information. CONTRACTOR agrees to promptly provide such information and maintenance recommendations to COUNTY at the inception of CONTRACTOR's work to the extent such information is reasonably available.

16. DEFAULT AND REMEDIES.

16.1. Default. In the event that (i) CONTRACTOR files a petition requesting relief under any bankruptcy act, or is adjudged as bankrupt, or makes a general assignment for the benefit of creditors or has a receiver appointed on account of its insolvency, or (ii) CONTRACTOR refuses or is unable, for whatever reason, to supply enough properly skilled workers or proper materials to complete the Project, or (iii) CONTRACTOR fails to follow the directions of COUNTY, or (iv) CONTRACTOR fails to make prompt payment to its subcontractors and suppliers for materials or labor supplied or permits any lien to be imposed upon all or any portion of the Project, or (v) CONTRACTOR disregards any laws or orders of any public or private authority having jurisdiction over the Work or the Project, or (vi) CONTRACTOR fails to

1 perform in accordance with any of the terms of this Agreement or breaches any
2 provision of this Agreement, COUNTY may give notice of such failure or breach to
3 CONTRACTOR, identifying the failure or breach of this Agreement. Should any
4 such failure or breach continue for twenty-four (24) hours after delivery of notice
5 without a good faith effort on the part of CONTRACTOR to commence all necessary
6 corrective action, or should such a breach continue despite CONTRACTOR's efforts
7 for forty-eight (48) hours, then at that time such failure shall be deemed a default by
8 CONTRACTOR under this Agreement and COUNTY shall have all rights and
9 remedies available at law or in equity, including the right to terminate this
10 Agreement. Without limiting its rights and remedies, COUNTY may then proceed as
11 follows:

12 **16.1.1.** Without terminating this Agreement or the obligations of CONTRACTOR
13 hereunder as to all of the Work required to be performed or furnished by
14 CONTRACTOR pursuant to this Agreement, COUNTY may require
15 CONTRACTOR, at CONTRACTOR's expense, to cure such default(s) as
16 may exist in the performance of CONTRACTOR's obligations hereunder
17 within forty-eight (48) hours after such default(s) has/have occurred including
18 but not limited to repairing, replacing and correcting material or Work
19 determined by COUNTY to be defective or not complying with the
20 requirements of this Agreement. Should CONTRACTOR fail to timely
21 repair, replace and/or correct non-complying or defective materials and
22 workmanship or otherwise cure its default(s) hereunder, and in the case of
23 emergencies in which case COUNTY may act immediately if
24 CONTRACTOR is not available or is not responding, and without further
25 notice, COUNTY may make required repairs, replacements and other
26 corrections or otherwise remedy the default by CONTRACTOR pursuant to
27 the subparagraph below.

28 **16.1.2.** Without terminating this Agreement or the obligations of CONTRACTOR
hereunder as to all of the Work required to be performed or furnished by

1 CONTRACTOR pursuant to this Agreement, COUNTY may engage another
2 contractor to perform such portion of CONTRACTOR's Work required
3 pursuant to this Agreement or furnish any materials or other items required
4 hereunder as COUNTY in its sole discretion may deem necessary to avoid
5 delay in the progress of the Work, and in connection therewith, COUNTY may
6 perform such Work or any portion thereof itself or have the same performed by
7 others and COUNTY may procure all necessary materials, equipment or other
8 items required for the continued progress of such Work. The costs incurred by
9 COUNTY as a result of engaging another contractor shall be deducted from the
10 compensation payable pursuant to this Agreement and if COUNTY's costs
11 exceed or may reasonably be anticipated to exceed the balance of the
12 compensation due to CONTRACTOR for such work, such excess, or
13 anticipated excess, shall be immediately due and owing from CONTRACTOR
14 to COUNTY and may be withheld from any funds due to CONTRACTOR
15 pursuant to this Agreement or any other agreement.

16 **16.1.3.** COUNTY may terminate CONTRACTOR's right to perform upon written
17 notice and COUNTY shall then have the option of completing the Work or
18 any portion thereof by exercise of its interest under the performance bond
19 issued in favor by CONTRACTOR, or having such Work in whole or in part
20 be completed by others for CONTRACTOR's account. A calculation shall
21 take place at the conclusion of the Project wherein to the degree the sum of
22 COUNTY's costs and any amounts paid to complete the Project exceed the
23 compensation payable pursuant to this Agreement, then any such excess shall
24 be immediately due and owing from CONTRACTOR to COUNTY.

25 **16.2. Damages.** CONTRACTOR shall be liable for all damages suffered by COUNTY by
26 reason of CONTRACTOR's default in any provision of this Agreement and the
27 exercise of COUNTY of its option to terminate this Agreement shall not release
28 CONTRACTOR of such liability. CONTRACTOR shall have no right to receive any
further payment after a default has occurred until such time as the Work to be

1 performed by CONTRACTOR pursuant hereto has been completed and accepted by
2 COUNTY and damages suffered by COUNTY, if any, ascertained. Damages shall
3 include by way of illustration, but not of exclusion, COUNTY's costs of completing
4 the Work which exceeds the compensation payable pursuant to this Agreement, other
5 general, liquidated, special or consequential damages, attorney fees and costs.

6 **16.3. Actions After Default.** Should COUNTY exercise any of its options, remedies or
7 rights granted pursuant to the terms of this Agreement in the event of a default by
8 CONTRACTOR, COUNTY at its sole election may, but shall not be obligated to, use
9 any materials, supplies, tools or equipment on the work site which belong to
10 CONTRACTOR to complete the Work required to be completed by CONTRACTOR,
11 whether such work is completed by COUNTY or by others, and CONTRACTOR
12 agrees that it shall not remove such materials, supplies, tools and equipment from the
13 work site unless directed in writing by COUNTY to do so.

14 **16.4. Limit on Force Majeure Damages.** CONTRACTOR shall not be responsible for
15 repairing or restoring damage to work caused by an act of God in excess of five (5)
16 percent of the contract amount, provided that the work damaged is built in accordance
17 with accepted and applicable building standards and the plans and specifications of
18 COUNTY. In the event of such damage, COUNTY may, at its option, elect to
19 terminate this Agreement. For purposes of this Agreement, an "act of God" shall be
20 defined as an earthquake in excess of 3.5 on the Richter Scale and a tidal wave.

21 **16.5. Resolution of Claims of Three Hundred Seventy-Five Thousand Dollars (\$375,000)**
22 **or Less.** For claims of three hundred seventy-five thousand dollars (\$375,000) or
23 less, COUNTY and CONTRACTOR agree to follow and comply with the mediation,
24 arbitration, claim, civil action procedure and trial de novo provisions set forth in
25 California Public Contracts Code §§20104, 20104.2 and 20104.4.

26 **16.6. No Limitation of Rights.** The options and rights granted to COUNTY herein shall not
27 be deemed as limitations upon the other rights and remedies of COUNTY in the event
28 of a failure of performance or breach by CONTRACTOR, and COUNTY shall be
entitled to exercise the rights and remedies hereinabove specified and all other rights

1 and remedies which may be provided in this Agreement or by law or in equity, either
2 cumulatively or consecutively, and in such order as COUNTY in its sole discretion
3 shall determine.

4 **17. NON-DISCRIMINATION.**

5 **17.1.** During the performance of this Agreement, CONTRACTOR and its subcontractors
6 shall not unlawfully discriminate, harass or allow harassment against any employee or
7 applicant for employment because of sex, race, color, ancestry, religious creed,
8 national origin, physical disability (including HIV and AIDS), mental disability,
9 medical condition (cancer), age (over forty (40)), marital status and denial of family
10 care leave.

11 **17.2.** CONTRACTOR and its subcontractors shall insure that the evaluation and treatment
12 of their employees and applicants for employment are free from such discrimination
13 and harassment.

14 **17.3.** CONTRACTOR and its subcontractors shall comply with the provisions of the Fair
15 Employment and Housing Act (Gov. Code §12990 (a-f) et seq.) and the applicable
16 regulations promulgated thereunder (California Code of Regulations, Title 2, Section
17 7285 et seq.).

18 **17.4.** The applicable regulations of the Fair Employment and Housing Commission
19 implementing Government Code §12990 (a-f), set forth in Chapter 5 of Division 4 of
20 Title 2 of the California Code of Regulations, are incorporated into this Agreement by
21 reference and made a part hereof as if set forth in full.

22 **17.5.** The applicable regulations of Section 504 of the Rehabilitation Act of 1973 (29
23 U.S.C. §794 (a)) are incorporated into this Agreement by reference and made a part
24 hereof as if set forth in full.

25 **17.6.** CONTRACTOR and its subcontractors shall give written notice of their obligations
26 under this clause to labor organizations with which they have a collective bargaining
27 or other agreement.

28 **17.7.** CONTRACTOR shall include the nondiscrimination and compliance provisions of
this clause in all subcontracts to perform Work under this Agreement.

1 **18. DISADVANTAGED BUSINESS ENTITY COMPLIANCE.**

2 **18.1.** CONTRACTOR and its subcontractors shall reference and abide by the guidance and
3 Disadvantaged Business Enterprise (“DBE”) specifications contained in the
4 California Department of Transportation’s Local Programs Procedures 06-01 (which
5 has been approved and released at (<http://www.dot.ca.gov/hq/LocalPrograms/>) when
6 working pursuant to this Agreement.

7 **18.2.** CONTRACTOR represents and warrants that is has fully read the applicable DBE
8 requirements pertaining to this Project and has fully and accurately completed any
9 and all required DBE forms.

10 **18.3.** CONTRACTOR represents and warrants that it will comply with all applicable DBE
11 requirements for this Project.

12 **18.4.** CONTRACTOR shall comply with the applicable DBE provisions attached hereto as
13 **Exhibit “D”** and incorporated by this reference as though fully set forth herein.

14 **18.5.** If any state or federal funds are withheld from COUNTY or not reimbursed to
15 COUNTY due to CONTRACTOR’s failure to either comply with the DBE
16 requirements set forth in the RFP and this Agreement, or to meet the mandatory DBE
17 goals as determined by COUNTY, Caltrans, the Federal Highway Administration,
18 and/or any other state or federal agency contributing funds to the Project, then
19 CONTRACTOR shall fully reimburse COUNTY the amount of funding lost.
20 COUNTY reserves the right to deduct any such loss in funding from the amount of
21 compensation due to CONTRACTOR under this Agreement.

22 **18.6.** In addition to the above, CONTRACTOR’s failure to comply with DBE
23 requirements/goals shall subject it to such sanctions as are permitted by law, which
24 may include, but shall not be limited to the following:

25 **18.6.1.** Termination of this Agreement;

26 **18.6.2.** Withholding monthly progress payments;

27 **18.6.3.** Compensatory, special, incidental, liquidated and other damages; and/or

28 **18.6.4.** Designation of CONTRACTOR as “nonresponsible,” and disqualification
from bidding on future public works projects advertised by COUNTY.

1 **19. PREVAILING WAGE.**

2 **19.1.** CONTRACTOR and its subcontractors shall pay all workers employed on the Project
3 the higher of either the rates determined by the Director of the California Department
4 of Industrial Relations (“DIR”) or, when applicable, the Davis-Bacon Federal wage
5 rates as supplemented by the Department of Labor regulations. The Davis-Bacon
6 Federal wage rates are attached to the RFP. Copies of the State prevailing rate of per
7 diem wages are on file with the Department of Industrial Relations, Division of
8 Apprenticeship Standards, 445 Golden Gate Avenue, San Francisco, California, and
9 at COUNTY’s Department of Public Works, and are available to CONTRACTOR
10 and any other interested party upon request. CONTRACTOR shall post the
11 prevailing rate of per diem wages to be posted at the Project site.

12 **19.2.** CONTRACTOR is responsible for compliance with the provisions herein.

13 **19.3. Mandatory Registration with the Department of Industrial Relations – NEW**
14 **REQUIREMENTS PURSUANT TO SB 854.**

15 **19.3.1.** CONTRACTOR and its subcontractors shall register with the DIR and pay all
16 applicable fees as set forth in Labor Code section 1725.5.

17 **19.3.2.** CONTRACTOR and its subcontractors acknowledge that they shall not be
18 listed on any bid proposal for a public works project (submitted on or after
19 March 1, 2015) unless registered with the DIR pursuant to Labor Code section
20 1725.5. The requirements of this section shall apply unless one of the limited
21 exceptions provided under Labor Code Section 1771.1(a) applies.

22 **19.3.3.** CONTRACTOR and its subcontractors acknowledge that they shall not be
23 awarded any contract for public work on a public works project (awarded on
24 or after April 1, 2015) unless registered with the DIR pursuant to Labor Code
25 section 1725.5.

26 **19.3.4.** The Project described herein is subject to compliance monitoring and
27 enforcement with the DIR.

28 **19.3.5.** For further information concerning compliance with SB 854, please visit:

<http://www.dir.ca.gov/Public-Works/SB854.html>.

1 **19.4. Cognizance of Violations by County.**

2 **19.4.1.** CONTRACTOR understands and agrees that COUNTY shall take cognizance
3 of violations of Chapter 1 of Part 7 of Division 2 of the California Labor Code
4 committed in the course of the execution of this Agreement, and shall
5 promptly report any suspected violations to the Labor Commissioner.

6 **19.4.2.** If CONTRACTOR determines as a result of its own investigation that there
7 has been a violation of Chapter 1 of Part 7 of Division 2 of the California
8 Labor Code and withholds payment to CONTRACTOR, the procedures in
9 California Labor Code §1771.6 shall be followed.

10 **19.4.3.** CONTRACTOR may bring an action in a court of competent jurisdiction to
11 recover from COUNTY the difference between the wages actually paid to an
12 employee and the wages that were required to be paid to an employee
13 pursuant to Chapter 1 of Part 7 of Division 2 of the California Labor Code,
14 any penalties required to be paid pursuant to Chapter 1 of Part 7 of Division 2
15 of the California Labor Code, and costs and attorney’s fees related to the
16 action, if either of the following is true:

17 **(a)** COUNTY previously affirmatively represented to CONTRACTOR in
18 writing, in the call for bids, or otherwise, that the Work was not a
19 “public work,” as defined in Chapter 1 of Part 7 of Division 2 of the
20 California Labor Code; or

21 **(b)** COUNTY received actual written notice from the Department of
22 Industrial Relations that the Work is a “public work,” as defined in
23 Chapter 1 of Part 7 of Division 2 of the California Labor Code, and
24 failed to disclose that information to CONTRACTOR before the bid
25 opening or award.

26 **19.5. Prevailing Wage Rates and Payroll Records.**

27 **19.5.1.** CONTRACTOR agrees to comply with §§1775 and 1776 of the California
28 Labor Code relating to the payment of prevailing wage and the maintenance
 of certified payroll records and to make the certified payroll records available

1 for inspection at all reasonable hours at CONTRACTOR's principal office.
2 The responsibility for compliance with these provisions is fixed with
3 CONTRACTOR. CONTRACTOR understands and agrees that it shall, as a
4 penalty to COUNTY, forfeit specific monetary fines for each worker paid less
5 than the prevailing wage rates as determined by the Labor Commissioner for
6 the work or craft in which the worker is employed for any Work done
7 pursuant to this Agreement.

8 **19.5.2. Prevailing Wage Compliance For those Projects subject to DIR Monitoring**
9 *and Enforcement.* CONTRACTOR has reviewed and agrees to comply with
10 any applicable provisions for those Projects subject to Department of
11 Industrial Relations (DIR) Monitoring and Enforcement of prevailing wages.
12 COUNTY hereby notifies CONTRACTOR that CONTRACTOR is
13 responsible for complying with the requirements of Senate Bill 854 (SB854)
14 regarding certified payroll record reporting. Further information concerning
15 the requirements of SB854 is available on the DIR website located at:
16 <http://www.dir.ca.gov/Public-Works/PublicWorksEnforcement.html>.

17 **19.5.3.** CONTRACTOR shall be liable for penalties pursuant to this section when a
18 subcontractor on the Project fails to pay its workers the general prevailing rate
19 of per diem wages and any of the following conditions are met:

- 20 (a) CONTRACTOR had knowledge of that failure of the subcontractor to
21 pay the specified prevailing rate of wages to those workers; or
22 (b) CONTRACTOR fails to comply with the following requirement: The
23 contract executed between CONTRACTOR and the subcontractor for
24 the performance of Work on the Project shall include a copy of the
25 provisions of California Labor Code §§1771, 1775, 1776, 1777.5,
26 1813 and 1815; and
27 (c) CONTRACTOR fails to comply with the following requirement:
28 CONTRACTOR shall monitor the payment of the specified general
prevailing rate of per diem wages by the subcontractor to the

1 employees, by periodic review of the certified payroll records of the
2 subcontractor; and

3 (d) Upon becoming aware of the failure of the subcontractor to pay his or
4 her workers the specified prevailing rate of wages, CONTRACTOR
5 shall diligently take corrective action to halt or rectify the failure,
6 including, but not limited to, retaining sufficient funds due the
7 subcontractor for work performed on the public works project; and

8 (e) Prior to making final payment to the subcontractor for Work
9 performed on the Project, CONTRACTOR shall obtain an affidavit
10 signed under penalty of perjury from the subcontractor that the
11 subcontractor has paid the specified general prevailing rate of per diem
12 wages to his or her employees on the Project and any amounts due
13 pursuant to California Labor Code §1813.

14 **19.6. Work Day and Work Week Requirements.** CONTRACTOR agrees to comply with
15 §§1810 through 1815 of the California Labor Code and, when applicable, sections
16 103 and 107 of the Contract Work Hours and Safety Standards Act, 40 U.S.C. §§3700
17 et seq., as supplemented by the Department of Labor regulations, which provide that
18 CONTRACTOR's workers and its subcontractor's workers may not be required or
19 permitted to work more than eight (8) hours in any one (1) calendar day and forty
20 (40) hours in any one (1) calendar week. Further, work performed by employees of
21 CONTRACTOR or its subcontractor in excess of eight (8) hours per day, and forty
22 (40) hours during any one (1) week, shall be compensated for all hours worked in
23 excess of eight (8) hours per day at not less than one and one-half (1½) times the
24 basic rate of pay. The responsibility for compliance with these provisions is fixed
25 with CONTRACTOR. CONTRACTOR understands and agrees that it shall, as a
26 penalty to COUNTY, forfeit specific monetary fines to COUNTY should
27 CONTRACTOR or its subcontractors fail to comply with the provisions contained
28 within this Paragraph.

19.7. Apprenticeship Requirements.

1 **19.7.1.** CONTRACTOR agrees to comply with §§1777.5, 1777.6 and 1777.7 of the
2 California Labor Code relating to the employment of apprentices and to
3 provide COUNTY with copies of any contract award information and verified
4 statements of the journeyman and apprentice hours performed pursuant to this
5 Agreement as required by §1777.5(e). The responsibility for compliance with
6 these provisions is fixed with CONTRACTOR for all apprenticeable
7 occupations, where journeymen in the craft are employed on the public work,
8 in a ratio of not less than one (1) apprentice for each five (5) journeymen
9 (unless an exemption is granted in accordance with §1777.5) and
10 CONTRACTOR and its subcontractors shall not discriminate among
11 otherwise qualified employees as indentured apprentices on any public work
12 solely on the ground of race, religious creed, color, national origin, ancestry,
13 sex, or age, except as provided in California Labor Code §3077. Only
14 apprentices, as defined in California Labor Code §3077, who are in training
15 under apprenticeship standards and who have signed written apprentice
16 agreements will be employed on public works in apprenticeable occupations.
17 This section shall not be enforced if the not-to-exceed amount of this
18 Agreement set forth and/or incorporated in the “COMPENSATION” Section
19 is less than thirty thousand dollars (\$30,000).

20 **19.7.2.** If the Project falls within the jurisdiction of California Labor Code §1777.5,
21 COUNTY shall, within five (5) days of the award, send a copy of the award to
22 the Division of Apprenticeship Standards. In addition, COUNTY shall notify
23 the Division of Apprenticeship Standards of a finding of any discrepancy
24 regarding the ratio of apprentices to journeymen within five (5) days of the
25 finding.

26 **19.8. Labor Standards Compliance Requirements.**

27 **19.8.1.** It is CONTRACTOR’s responsibility to provide all labor compliance
28 documentation from its subcontractors completely and accurately in a timely
 manner. CONTRACTOR is responsible to review promptly and then forward

1 on all required documentation to COUNTY per the time schedules in the
2 Labor Compliance Handout. Included with the Labor Compliance Handout,
3 COUNTY will provide training, documentation requirements, forms, etc., at
4 the preconstruction conference or at a time designated by COUNTY.

5 **19.8.2.** In the event, during the review process of labor compliance documentation
6 from COUNTY's labor compliance monitor, inaccurate, missing or incomplete
7 information was provided, the labor compliance monitor will request from
8 CONTRACTOR the items, revisions and documentation needed. The cost of
9 this additional labor compliance enforcement shall be borne by
10 CONTRACTOR.

11 **20. SIGNAGE REQUIREMENTS.**

12 **20.1. Project Identity Signage.** CONTRACTOR is required to provide and install the
13 required project identity signage as detailed in the Plans and Specifications, in the
14 size and at the location indicated by the Director of Public Works or his/her designee,
15 and to maintain the signage in good condition for the duration of the Project. The
16 signage may not be removed until the Notice of Completion is recorded or by written
17 direction of the Director of Public Works or his/her designee.

18 **20.2. Required Employee Signage and Posters.** CONTRACTOR is required to provide and
19 install the Federal and State required employee posters and the required material
20 pertaining to the required labor standards provisions are posted (including, but not
21 limited to, WH-1321, OSHA 3165 and OFCCP-English, EFCCP-Spanish) at the
22 worksite in a prominent and accessible place.

23 **20.3. Section 3 Compliant Signage.** If required by COUNTY, CONTRACTOR is directed
24 to provide and install the "Offer for Employment" signage as detailed in the Plans and
25 Specifications in the size and at the location indicated by the Director of Public
26 Works or his/her designee and to maintain the signage in good condition for the
27 duration of the Project. The signage may not be removed until the Notice of
28 Completion is recorded or by written direction of the Director of Public Works or
his/her designee.

1 **21. CONFLICT OF INTEREST AND GRATUITIES.**

2 **21.1.** CONTRACTOR agrees that it presently has no interest and shall not acquire any
3 interest, direct or indirect, which could conflict in any manner or degree with the
4 performance of services required to be performed under this Agreement.
5 CONTRACTOR further agrees that in the performance of this Agreement, no person
6 having any such interest shall be employed.

7 **21.2.** CONTRACTOR agrees to designate such person or persons who have responsibility
8 for carrying out the services under this Agreement and that such person or persons as
9 may be designated shall take any and all actions necessary to comply with
10 COUNTY's Conflict of Interest Code adopted pursuant to California Government
11 Code §81000 to the extent required thereunder.

12 **21.3.** If it is found, after notice and hearing by COUNTY, that gratuities (in the form of
13 entertainment., gifts, or otherwise) were offered or given by CONTRACTOR, or any
14 agent or representative of CONTRACTOR, to any officer, employee or agent of
15 COUNTY with a view toward securing a contract or securing favorable treatment
16 with respect to the awarding or amending or the making of any determinations with
17 respect to the performance of this Agreement, COUNTY may, by written notice to
18 CONTRACTOR, terminate the right of CONTRACTOR to proceed under this
19 Agreement and/or may pursue such other rights and remedies provided by law or
20 under this Agreement.

21 **21.4.** In the event this Agreement is terminated as provided herein, COUNTY shall be
22 entitled to:

23 **21.4.1.** Pursue the same remedies against CONTRACTOR as it could pursue in the
24 event of a breach of the Agreement by CONTRACTOR; and

25 **21.4.2.** As a penalty in addition to any other damages to which it may be entitled by
26 law, to exemplary damages in an amount (as determined by COUNTY) which
27 shall be not less than three (3) nor more than ten (10) times the costs incurred
28 by CONTRACTOR in providing any such gratuities to any such officer,
employee or agent.

1 **22. HOUSING AND URBAN DEVELOPMENT ACT COMPLIANCE.**

2 When applicable, CONTRACTOR agrees to comply with Section 3 of the Housing and
3 Urban Development Act of 1968 (42 U.S.C. 3601 et seq.) which provides that to the greatest extent
4 feasible, CONTRACTOR shall provide job training, employment and contracting opportunities for
5 low- or very-low income residents in connection with the Project. The responsibility for compliance
6 with these provisions is fixed with CONTRACTOR.

7 **23. COPELAND "ANTI-KICKBACK" ACT COMPLIANCE.**

8 When applicable, CONTRACTOR agrees to comply with the Copeland Act
9 ([18 USC §874](#) and [40 USC §276c](#); [29 C.F.R. Part 3](#)) which precludes CONTRACTOR and its
10 subcontractors from in any way inducing an employee to give up any part of the compensation to
11 which he or she is entitled under his or her contract of employment. CONTRACTOR and its
12 subcontractors shall submit a weekly statement of the wages paid to each employee performing on
13 covered work during the preceding payroll period. CONTRACTOR understands and agrees that
14 should CONTRACTOR its subcontractors induce an employee working on a covered contract to
15 give up any part of the compensation to which he or she is entitled, the inducing party may be
16 subject to a five thousand dollar (\$5,000) fine, or imprisonment for up to five (5) years, or both.
17 CONTRACTOR also understands and agrees that willful falsification of the statement of compliance
18 may subject the employer to civil or criminal prosecution and may be cause for contract termination
19 or debarment. The responsibility for compliance with these provisions is fixed with
20 CONTRACTOR.

21 **24. FAIR LABOR STANDARDS ACT COMPLIANCE.**

22 When applicable, CONTRACTOR agrees to comply with the Fair Labor Standards Act of
23 1938 as amended (29 U.S.C. 201 et seq.) which establishes minimum wage, overtime pay,
24 recordkeeping, and youth employment standards affecting full-time and part-time workers on the
25 Project. The responsibility for compliance with these provisions is fixed with CONTRACTOR.

26 **25. CERTIFICATION REGARDING DEBARMENT, SUSPENSION AND OTHER**
27 **RESPONSIBILITY MATTERS.**

28 When applicable, CONTRACTOR agrees to execute a certification regarding debarment,
suspension and other responsibility matters. The responsibility for compliance with this provision is

1 fixed with CONTRACTOR.

2 **26. FEDERAL EQUAL EMPLOYMENT OPPORTUNITY CONSTRUCTION**
3 **CONTRACT SPECIFICATIONS.**

4 When applicable, CONTRACTOR agrees to incorporate the notice set forth in paragraph (d)
5 of 41 C.F.R. 60-4.2 relating to the “Equal Opportunity Clause” and the “Standard Federal Equal
6 Employment Specifications.” The responsibility for compliance with this provision is fixed with
7 CONTRACTOR.

8 **27. CLEAN AIR ACT AND THE FEDERAL WATER POLLUTION CONTROL ACT.**

9 When applicable, CONTRACTOR agrees to comply with all applicable standards, orders or
10 regulations issued pursuant to the Clean Air Act (42 U.S.C. 7401 et seq.), the Federal Water
11 Pollution Control Act as amended (33 U.S.C. 1251 et seq.), Presidential Executive Order 11738 and
12 Environmental Protection Agency regulations set forth at 40 C.F.R. Part 15. CONTRACTOR
13 understands and agrees that violations shall be reported to the Federal awarding agency and the
14 Regional Office of the Environmental Protection Agency. The responsibility for compliance with
15 these provisions is fixed with CONTRACTOR.

16 **28. PROHIBITION ON THE USE OF FEDERAL FUNDS FOR LOBBYING.**

17 When applicable, CONTRACTOR shall file the required certification. Each tier certifies to
18 the tier above that it will not and has not used Federal appropriated funds to pay any person or
19 organization for influencing or attempting to influence an officer or employee of any agency, a
20 member of Congress, officer or employee of Congress, or an employee of a member of Congress in
21 connection with obtaining any Federal contract, grant or any other award covered by 31 U.S.C.
22 1352. Each tier shall also disclose any lobbying with non-Federal funds that takes place in
23 connection with obtaining any Federal award. Such disclosures are forwarded from tier to tier up to
24 the recipient. The responsibility for compliance with this provision is fixed with CONTRACTOR.

25 **29. FEDERAL EMPLOYMENT ELIGIBILITY VERIFICATION.**

26 CONTRACTOR shall verify name, date of birth and social security number, along with
27 immigration information for non-citizens in order to verify the identity and employment eligibility of
28 both citizen and non-citizen new hires. The responsibility for compliance with this provision is fixed
with CONTRACTOR.

1 **30. THE CIVIL RIGHTS, HCD AND AGE DISCRIMINATION ACT ASSURANCES.**

2 During the performance of this Agreement, CONTRATOR assures that no otherwise
3 qualified person shall be excluded from participation or employment, denied program benefits or be
4 subjected to discrimination based on race, color, national origin, gender, age or handicap, under any
5 program or activity funded by this Agreement, as required by Title VI of the Civil Rights Act of
6 1964, Title I of the Housing and Community Development Act of 1974, as amended, and the Age
7 Discrimination Act of 1975, and all implementing regulations. The responsibility for compliance
8 with these provisions is fixed with CONTRACTOR.

9 **31. STANDARD EQUAL OPPORTUNITY CLAUSE.**

10 **31.1.** CONTRACTOR hereby agrees that it will incorporate or cause to be incorporated
11 into any contract for construction work, or modification thereof, as defined in the
12 regulations of the Secretary of Labor at 41 C.F.R. Chapter 60, which is paid for in
13 whole or in part with funds obtained from the Federal Government or borrowed on
14 the credit of the Federal Government pursuant to a grant, contract, loan insurance, or
15 guarantee, or undertaken pursuant to any Federal program involving such grant,
16 contract, loan, insurance, or guarantee, the following equal opportunity clause:

17 *“During the performance of this contract, the Contractor agrees as follows:*

- 18 (1) *The contractor will not discriminate against any employee or applicant*
19 *for employment because of race, color, religion, sex, or national origin.*
20 *The contractor will take affirmative action to ensure that applicants are*
21 *employed, and that employees are treated during employment, without*
22 *regard to their race, color, religion, sex, or national origin. Such action*
23 *shall include, but not be limited to the following: Employment,*
24 *upgrading, demotion, or transfer, recruitment or recruitment*
25 *advertising; layoff or termination; rates of pay or other forms of*
26 *compensation; and selection for training, including apprenticeship. The*
27 *contractor agrees to post in conspicuous places, available to employees*
28 *and applicants for employment, notices to be provided by the*
contracting officer setting forth the provisions of this nondiscrimination

1 clause.

- 2 (2) The contractor will, in all solicitations or advertisements for employees
3 placed by or on behalf of the contractor, state that all qualified
4 applicants will receive consideration for employment without regard to
5 race, color, religion, sex, or national origin.
- 6 (3) The contractor will send to each labor union or representative of
7 workers with which he has a collective bargaining agreement or other
8 contract or understanding, a notice to be provided by the agency
9 contracting officer, advising the labor union or workers' representative
10 of the contractor's commitments under section 202 of Executive Order
11 11246 of September 24, 1965, and shall post copies of the notice in
12 conspicuous places available to employees and applicants for
13 employment.
- 14 (4) The contractor will comply with all provisions of Executive Order
15 11246 of September 24, 1965, and of the rules, regulations, and relevant
16 orders of the Secretary of Labor.
- 17 (5) The contractor will furnish all information and reports required by
18 Executive Order 11246 of September 24, 1965, and by the rules,
19 regulations, and orders of the Secretary of Labor, or pursuant thereto,
20 and will permit access to his books, records, and accounts by the
21 contracting agency and the Secretary of Labor for purposes of
22 investigation to ascertain compliance with such rules, regulations, and
23 orders.
- 24 (6) In the event of the contractor's non-compliance with the
25 nondiscrimination clauses of this contract or with any of such rules,
26 regulations, or orders, this contract may be canceled, terminated or
27 suspended in whole or in part and the contractor may be declared
28 ineligible for further Government contracts in accordance with
procedures authorized in Executive Order 11246 of September 24,

1 1965, and such other sanctions may be imposed and remedies invoked
2 as provided in Executive Order 11246 of September 24, 1965, or by
3 rule, regulation, or order of the Secretary of Labor, or as otherwise
4 provided by law.

5 (7) the contractor will include the provisions of paragraphs (1) through (7)
6 in every subcontract or purchase order unless exempted by rules,
7 regulations, or orders of the Secretary of Labor issued pursuant to
8 section 204 of Executive Order 11246 of September 24, 1965, so that
9 such provisions will be binding upon each subcontractor or vendor. The
10 contractor will take such action with respect to any subcontract or
11 purchase order as may be directed by the Secretary of Labor as a means
12 of enforcing such provisions including sanctions for noncompliance:
13 Provided, however, that in the event the contractor becomes involved in,
14 or is threatened with, litigation with a subcontractor or vendor as a
15 result of such direction, the contractor may request the United States to
16 enter into such litigation to protect the interests of the United States.”

17 **31.2.** CONTRACTOR further agrees that it will be bound by the above equal opportunity
18 clause with respect to its own employment practices when it participates in federally-
19 assisted construction work; provided that if CONTRACTOR so participating is a
20 State or local government, the above equal opportunity clause is not applicable to any
21 agency, instrumentality, or subdivision of such government which does not
22 participate in work on or under the Agreement.

23 **31.3.** CONTRACTOR agrees that it will assist and cooperate actively with the
24 administering agency and the Secretary of Labor in obtaining the compliance of
25 Contractors and subcontractors with the equal opportunity clause and the rules,
26 regulations, and relevant orders of the Secretary of Labor, that it will furnish the
27 Department and HUD and the Secretary of Labor such information as they may
28 require for the supervision of such compliance, and that it will otherwise assist the
 administering agency in the discharge of the agency’s primary responsibility for

1 securing compliance.

2 **31.4.** CONTRACTOR further agrees that it will refrain from entering into any contract or
3 contract modification subject to Executive Order 11246 of September 24, 1965, with
4 a contractor debarred from, or who has not demonstrated eligibility for, government
5 contracts and federally-assisted construction contracts, pursuant to the Executive
6 Order and will carry out such sanctions and penalties for violation of the equal
7 opportunity clause as may be imposed upon contractors and subcontractors by the
8 administering agency or the Secretary of Labor pursuant to Part II, Subpart D of the
9 Executive Order. In addition, CONTRACTOR agrees that if it fails or refuses to
10 comply with these undertakings, COUNTY may take any or all of the following
11 actions: Cancel, terminate, or suspend in whole or in part this funding commitment
12 (contract, loan, grant, insurance, guarantee); refrain from extending any further
13 assistance to the applicant under the program with respect to which the failure or
14 refund occurred until satisfactory assurance of future compliance has been received
15 from such Contractor; and refer the case to the Department of Justice for appropriate
16 legal proceedings.

17 **32. ASSIGNMENT OF UNFAIR BUSINESS PRACTICES CLAIMS (CLAYTON ACT**
18 **AND CARTWRIGHT ACT).**

19 CONTRACTOR and its subcontractors offer and agree to assign to COUNTY all rights, title
20 and interest in and to all causes of action it may have under Section 4 of the Clayton Act ([15 U.S.C.](#)
21 [§15](#)) or under the Cartwright Act (Chapter 2 (commencing with §16700) of Part 2 of Division 7 of
22 the Business and Professions Code), arising from purchases of goods, services or materials pursuant
23 to this Agreement. This assignment shall be made and become effective at the time COUNTY
24 tenders final payment to CONTRACTOR, without further acknowledgment by the Parties.

25 **33. NON-COLLUSION.**

26 CONTRACTOR agrees he/she has executed and submitted with the Bid a Non-Collusion
27 Affidavit that complies with Cal. Public Code §7106, included in **Exhibit “B”** and incorporated
28 herein.

34. **NOTICES AND REPORTS.**

1 **34.1.** All notices and reports under this Agreement shall be in writing and may be given by
2 personal delivery or by mailing by certified mail, addressed as follows:

3 COUNTY

4 Imperial County Department of Public Works
5 Attention: Director
6 155 South Eleventh Street
7 El Centro, CA 92243

CONTRACTOR

 «Consultant_Business_Name»
 «Consultant_Street_Address»
 «Consultant_City_State»

8 with copies to:

9 Imperial County Executive Office
10 Attention: County Executive Officer
11 940 West Main Street, Suite 208
12 El Centro, CA 92243

13 and:

14 Imperial County Department of Human
15 Resources and Risk Management
16 Attention: Director
17 940 West Main Street, Suite 101
18 El Centro, CA 92243

19 **34.2.** Notices and reports under this Agreement may be given by personal delivery or by
20 mailing by certified mail at such other address as either Party may designate in a
21 notice to the other Party given in such manner. Any notice given by mail shall be
22 considered given when deposited in the United States Mail, postage prepaid,
23 addressed as provided herein.

24 **35. ENTIRE AGREEMENT.**

25 This Agreement contains the entire agreement between COUNTY and CONTRACTOR
26 relating to the transactions contemplated hereby and supersedes all prior or contemporaneous
27 agreements, understandings, provisions, negotiations, representations, or statements, either written or
28 verbal.

36. ASSIGNMENT.

 Neither this Agreement nor any duties or obligations hereunder shall be assignable by
 CONTRACTOR without the prior written consent of COUNTY.

37. MODIFICATION.

1 No modification, waiver, amendment, discharge, or change of this Agreement shall be valid
2 unless the same is in writing and signed by the Party against whom the enforcement of such
3 modification, waiver, amendment, discharge, or change is or may be sought.

4 **38. CAPTIONS.**

5 Captions in this Agreement are inserted for convenience of reference only and do not define,
6 describe or limit the scope or the intent of this Agreement or any of the terms thereof.

7 **39. PARTIAL INVALIDITY.**

8 If any provision in this Agreement is held by a court of competent jurisdiction to be invalid,
9 void, or unenforceable, the remaining provisions will nevertheless continue in full force without
10 being impaired or invalidated in any way.

11 **40. GENDER AND INTERPRETATION OF TERMS AND PROVISIONS.**

12 Words and expressions in the masculine gender include the feminine and neuter genders.
13 Words and expressions in the singular include the plural and words and expressions in the plural
14 include the singular. CONTRACTOR as used in this Agreement or in any other document referred
15 to in or made a part of this Agreement shall likewise include both singular and the plural, a
16 corporation, a partnership, individual, firm or person acting in any fiduciary capacity as executor,
17 administrator, trustee or in any other representative capacity or any other entity. All covenants
18 herein contained on the part of CONTRACTOR shall be joint and several if more than one person,
19 firm or entity executes the Agreement.

20 **41. WAIVER.**

21 No waiver of any breach or of any of the covenants or conditions of this Agreement shall be
22 construed to be a waiver of any other breach or to be consent to any further or succeeding breach of
23 the same or any other covenant or condition.

24 **42. CHOICE OF LAW.**

25 The laws of the State of California shall govern this Agreement. This Agreement is made
26 and entered into in Imperial County, California. Any action brought by either Party with respect to
27 this Agreement shall be brought in a court of competent jurisdiction within said County.

28 **43. AUTHORITY.**

43.1. Each individual executing this Agreement on behalf of CONTRACTOR represents

1 and warrants that:

2 **43.1.1.** He/She is duly authorized to execute and deliver this Agreement on behalf of
3 CONTRACTOR;

4 **43.1.2.** Such execution and delivery is in accordance with the terms of the Articles of
5 Incorporation or Partnership, any by-laws or Resolutions of CONTRACTOR
6 and;

7 **43.1.3.** This Agreement is binding upon CONTRACTOR in accordance with its
8 terms.

9 **43.2.** CONTRACTOR shall deliver to COUNTY evidence acceptable to COUNTY of the
10 foregoing within thirty days of execution of this Agreement.

11 **44. COUNTERPARTS.**

12 This Agreement and any subsequent modifications may be executed in any number of
13 counterparts, each of which when executed shall be an original, and all of which together shall
14 constitute one and the same Agreement. No counterparts shall be effective until all Parties have
15 executed a counterpart hereof.

16 **45. TIMING.**

17 The Parties agree that time is of the essence in this Agreement.

18 **46. REVIEW OF AGREEMENT TERMS.**

19 **46.1.** Each Party has had the opportunity to receive independent legal advice from its
20 attorneys with respect to the advisability of making the representations, warranties,
21 covenants and agreements provided for herein, and with respect to the advisability of
22 executing this Agreement.

23 **46.2.** Each Party represents and warrants to and covenants with the other Party that:

24 **46.2.1.** This Agreement in its reduction to final written form is a result of extensive
25 good faith negotiations between the Parties and/or their respective legal
26 counsel; and

27 **46.2.2.** The Parties and/or their legal counsel have carefully reviewed and examined
28 this Agreement for execution by said Parties.

46.3. Any statute or rule of construction that ambiguities are to be resolved against the

1 drafting party shall not be employed in the interpretation of this Agreement.

2 **IN WITNESS WHEREOF**, the Parties have executed this Agreement on the day and year
3 first above written.

4 **County of Imperial**

5 **«Consultant_Business_Name»**

6 By: _____
7 Raymond R. Castillo, Chairman
8 Imperial County Board of Supervisors

6 By: _____
7 «Consultant_Name_for_Signature»

9 **ATTEST:**

10
11 By: _____
12 Blanca Acosta,
13 Clerk of the Board of Supervisors

14 **APPROVED AS TO FORM:**

15
16 Katherine Turner,
17 County Counsel

18
19 By: _____
20 «CC_Attorney»,
21 «CC_Attorney_Title»

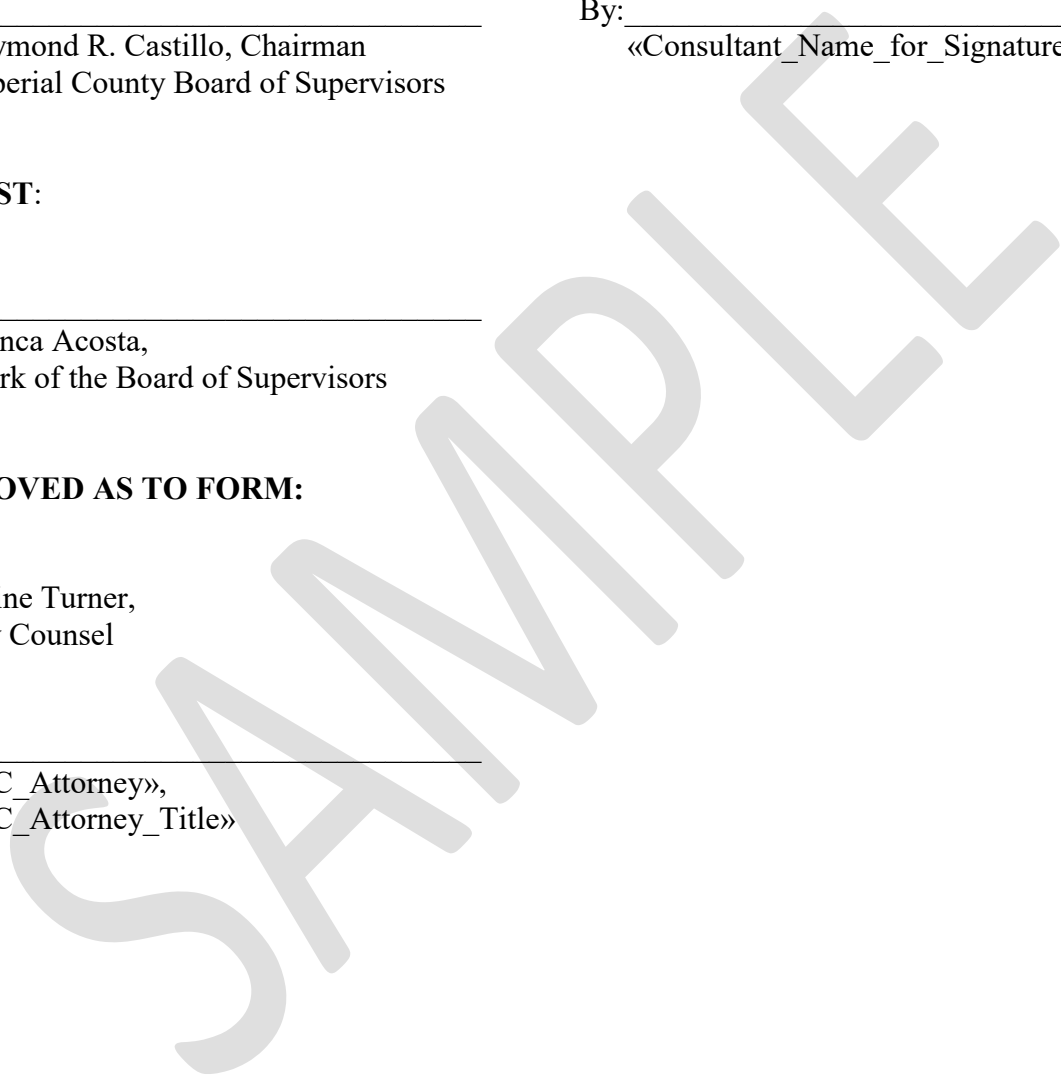

22
23
24
25
26
27
28